

PG700 Dimensional Drawings

PG700 (floor mounting) Main Unit

0.31 kg 0.7 lb

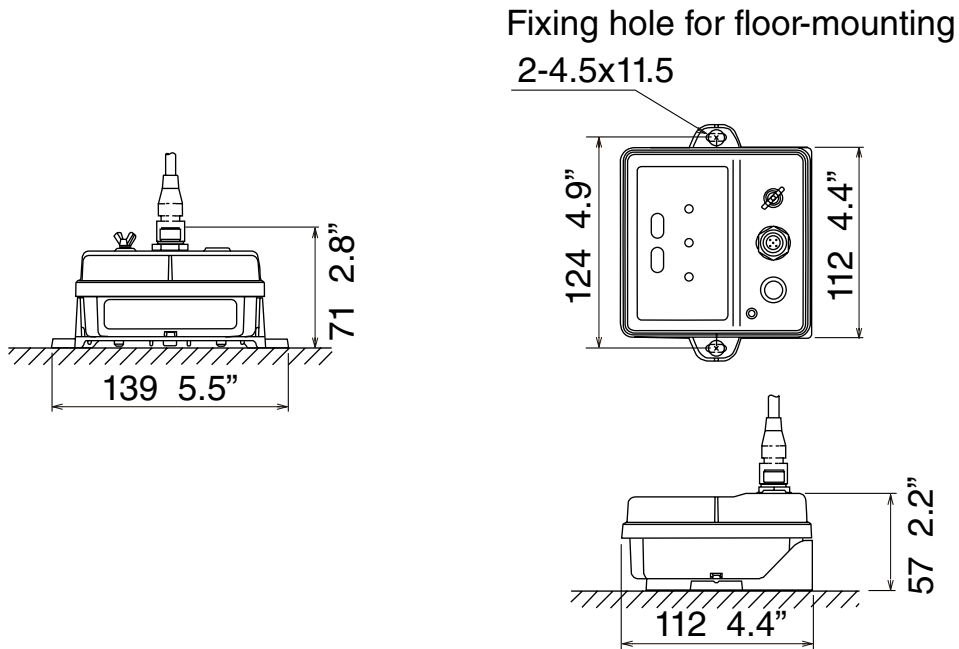

PG-700 (bulkhead mounting) Main Unit

0.35 kg 0.77 lb

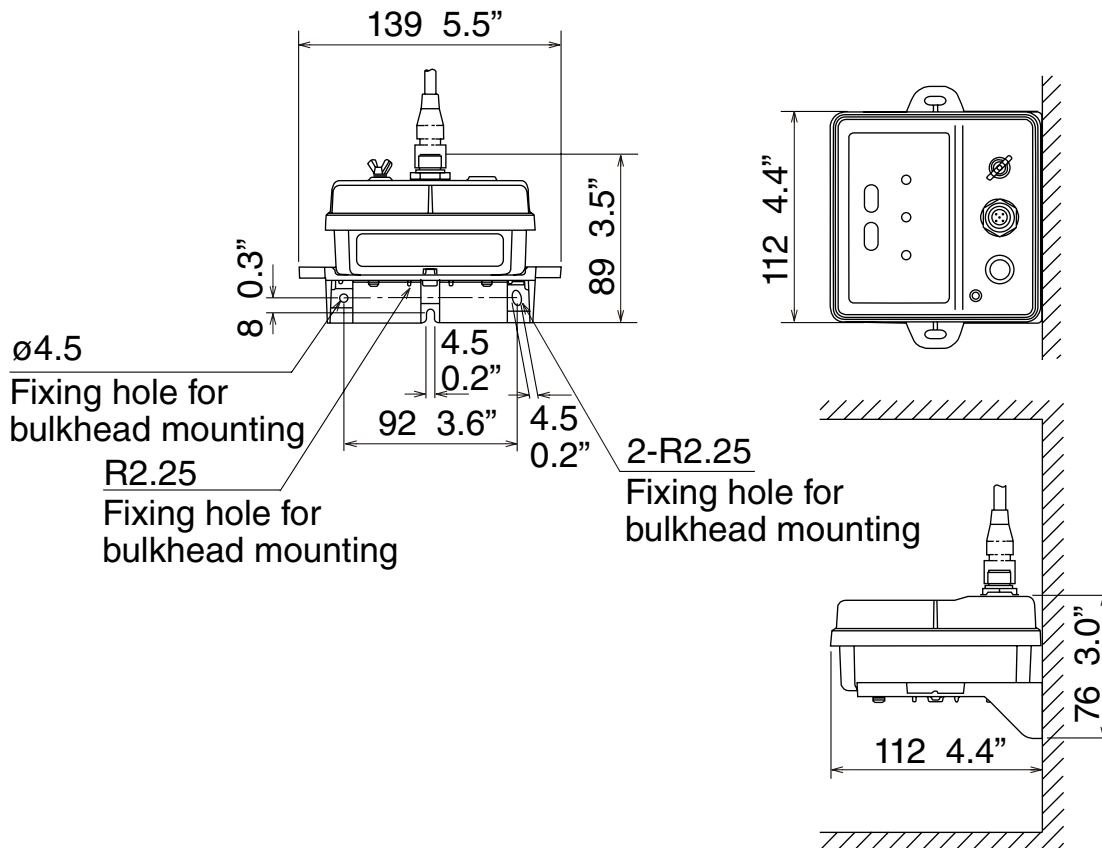

NavNet 3D MFD12 Dimensional Drawings:

Multi Function Display (Table-top Mount) MFD12

6.8 kg 15.0 lb

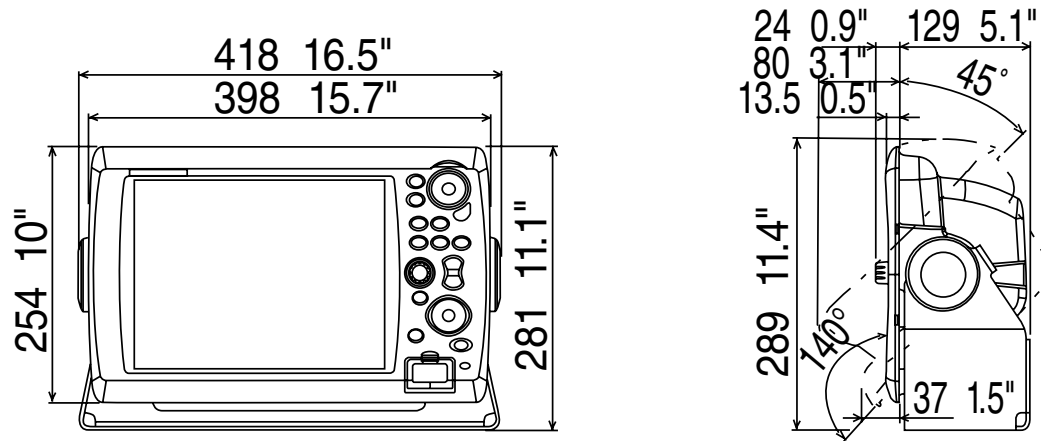

Multi Function Display (Flush Mount) MFD12

5.4 kg 11.9 lb

