

# SPECIFICATIONS OF RD-33

## GENERAL

**Screen Size**  
4.3" color LCD

**Effective Display Area**  
95.04 (W) x 53.85 (H) mm

**Pixel Number**  
480 (V) x 272 (H) pixels

**Display Style**  
1/2/3/4 data, Highway, Graph, Alphanumeric, 6-way split

**Display Mode**  
Nav data, Highway, Heading, Speed, Depth Graph, Graph, Layline, STW, SOG, RPM, Rudder, Wind angle, Airtemp, Humid, Roll pitch, ROT, Battery, Engine temp, Oil pressure, Oil temperature, Coolant pressure, Trim, Watch

## INTERFACE

**Ports**  
NMEA0183 (ver. 2.0, 3.0): 1, CAN bus: 2 (male/female)

### Input

**NMEA0183**  
APB BWR BWC CUR DBT DPT DBS DBK GLL GGA GNS GTD GLC HDT HDG HDM MTW MDA MWV RSA RMA RMB RMC ROT VHW VBW VTC VWT VWR VDR XTE ZTG ZDA PFEC, Gpatt (Pitch & Roll)

**CAN bus**  
059392 059904 060928 126208 126992 127245 127250 127257 127258 127488 127489 127497 128259 128267 128275 129025 129029 129033 129285 130306 130310 130311 130577 130823

### Output

**NMEA0183**  
DPT, VHW, RMC, MWV, HDT, HDG, XTE, MTW, RSA, VTC

**CAN bus**  
059392 059904 060928 065282 126208 126464 126996 126992 127245 127250 128259 128267 129026 129029 129283 130306 130311

**POWER SUPPLY**  
15 VDC : LEN6 (CAN bus)  
12-24 VDC : 0.2-0.1 A (Non CAN bus)

### ENVIRONMENT

**Temperature**  
-15°C to +55°C

**Waterproofing**  
IP56

### EQUIPMENT LIST

- Standard**
1. Display unit RD-33 with 6m cable 1 unit
  2. Standard spare parts and installation materials
- Option**
1. Junction box FI-5002
  2. Cable assembly FI-50-CHAIN 0.3/1/5/10/20 m
  3. Cable assembly M12-05BM+05BF 1/2/6 m
  4. Cable assembly MJ-A6SPF0003 2/5/10/15 m

### OFFICIAL NAME OF THE EQUIPMENT

Remote Display RD-33

## Display Unit RD-33

0.70 kg 1.54 lb

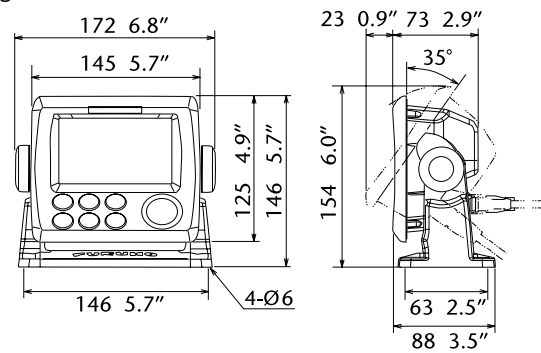

Flush mount  
0.59 kg 1.3 lb

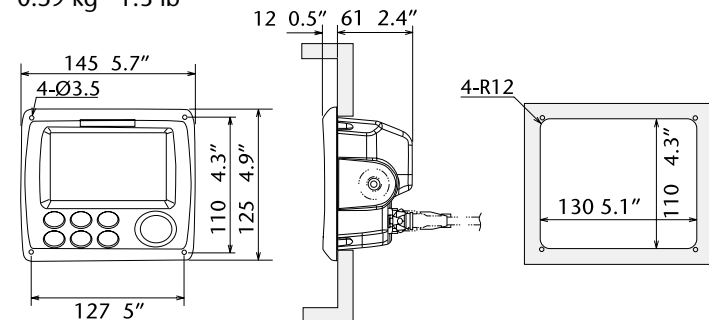

## INTERCONNECTION DIAGRAM

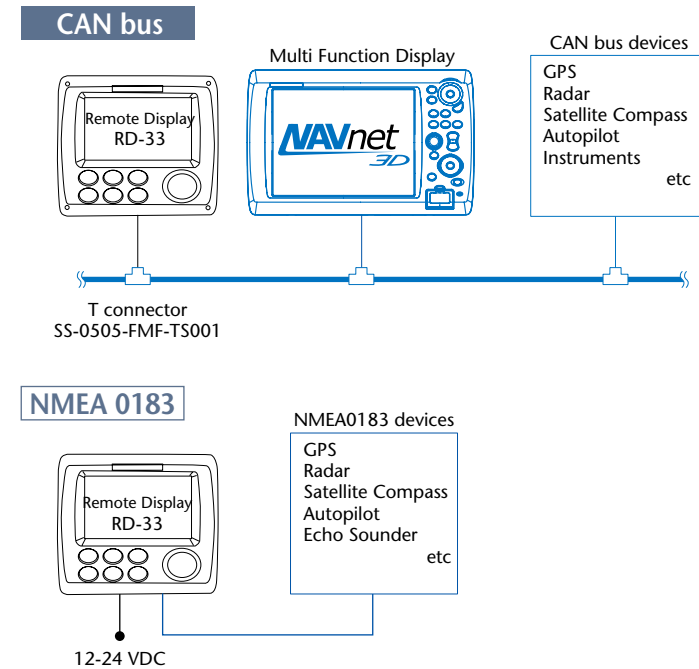

For further info, contact our local distributor  
— option or local supply

SPECIFICATIONS SUBJECT TO CHANGE WITHOUT NOTICE  
All brand and product names are registered trademarks, trademarks or service marks of their respective holders



# FURUNO

# RD-33

## REMOTE DISPLAY





# The new, intuitive graphic remote display lets you easily view the data you need.

The RD-33 is a navigational data organizer that allows the operator to select the perfect way to display data from interfaced equipment such as GPS, chartplotter, radar, fish finder, autopilot, instruments and other sensors including engine information.

The high contrast, color 4.3" LCD may be installed in a compact space, remote from its sources. The screen is impressively bright, remarkably crisp and easy to read.

Various display modes are available including Speedometer, Highway and Text. The text mode presents up to six of the most necessary types of data. The display layout can be customized for your specific needs.

This versatile product can also be added to a NavNet 3D system, displaying a variety of navigation data from the CAN bus network.



- ▶ 4.3" "Sunlight Viewable" color LCD (Brightness: 700 cd)
- ▶ Enhanced data legibility thanks to large characters and high resolution display
- ▶ Customizable display format from Full-screen to a 6-way split screen presentation
- ▶ Supports both CAN bus and NMEA0183 interfaces
- ▶ Two independent CAN bus input and output ports incorporated for daisy chain networking
- ▶ Internal NMEA0183/CAN bus conversion capability available
- ▶ Simultaneous alarm monitoring capabilities for the following data:

Water Temp/Depth/Speed/Arrival/Anchor/XTE/Trip/Odometer/Timer and Countdown Timer/Roll & Pitch/Wind Speed/Wind Direction/Battery



**RD-33**  
REMOTE DISPLAY



## Display a Variety of Information

The RD-33 accepts a wide variety of [navigation](#) data and displays them in numerical and graphic formats. You may freely select and arrange which data is displayed on the screen. Furthermore, seven patterns of customized display settings can be stored in the memory to give speedy access and convenience while onboard.

### Data To Be Displayed

#### Depth

Depth

#### Speed

Speed Through Water, Maximum /Average Speed Through Water, Speed Over Ground, Maximum/Average Speed Over Ground, Velocity Made Good, Trip, Odometer

#### Timer

Stopwatch, Timer

#### Wind

Wind Speed, Maximum True Wind Speed, Wind Angle, Low Apparent Wind Angle, High Apparent Wind Angle, Beaufort Wind, Ground Wind

#### Heading

Heading, Heading Average, Locked Heading, Next Tack, Course Over Ground, Course Made Good, Distance Made Good, Rate Of Turn

#### Navigation

Bearing, Locked Bearing, Range to Destination, Cross Track Error, Waypoint No., Waypoint Name, Position, Course Over Ground, Speed Over Ground, Satellites, Roll/Pitch, Roll, Pitch, Destination, Estimated Time of Arrival, Time, ETA Date, Time Difference, Laylines

#### Environment

Voltage, Time, Date, Water Temperature, Air Temperature, Air Pressure, Humidity, Wind Chill, Dew Point

#### Autopilot

Rudder Angle

#### Engine

Fuel Information, Fuel Rate, Engine RPM, Engine Trim, Boost, Engine Temperature, Engine Hours, Oil Press, Oil Temperature, Coolant, Engine Load

#### Fishery

Current Speed, Current Direction

## Graphic Display Styles

The RD-33 features a visually appealing fresh new look, combining easy access with user functionality. Thanks to the bright, high-resolution LCD, the RD-33 provides an easy-to-read display to monitor information from remote equipment, through an intuitive graphical user interface.

### NAV data



### SOG



### Roll & Pitch

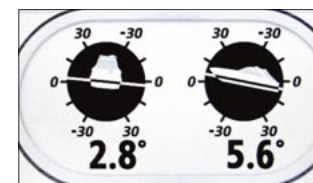
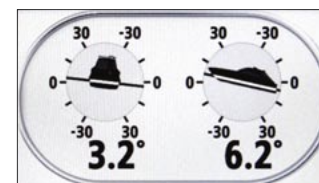

### Heading



### Wind

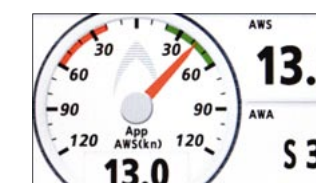

### Rate of Turn

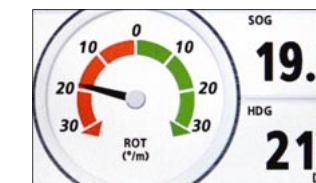
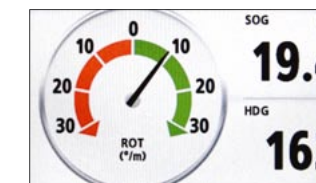

## What is CAN bus?

CAN bus is a communication protocol that shares multiple data and signals through a single backbone cable. You can simply connect any CAN bus devices onto the backbone cable to expand your network onboard. With CAN bus, IDs are assigned to all the devices, and the status of each sensor in the network can be detected. All the CAN bus devices can be incorporated into the NMEA2000 network.



## Customizable Split-Screen Presentation

You can customize the view to display the information in the format that works best for you. The RD-33 allows you to split the screen in up to six separate segments and provides graphical or numerical representations of environmental sign changes to facilitate navigation.

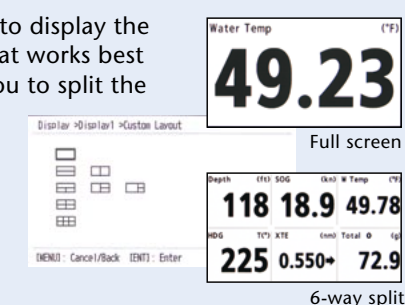

6-way split