



OVER PLATFORM TELESCOPING LADDER

MOUNTING INSTRUCTIONS

Thank you for selecting our superior quality Garelick EEz-In Brand Boarding Ladder. Your ladder was designed and manufactured using the finest material available to provide long product life. Choosing the proper size ladder for location and correct fit is important to assure safe, convenient, and reliable use.

To select the proper length ladder, choose one that allows at least two steps under water when ladder is deployed.

Choose the most suitable side of your transom platform for mounting the ladder. When mounting, locate a place where the ladder will not interfere with the turning of the motor or be near the propeller of your craft.

See Figure 1

1. Using the gudgeon as a template, mark the four bracket holes on the platform for drilling at desired location. **NOTE:** Make certain that the brackets are located on a strong, solid surface of the platform. If this is not possible, use a backing plate as shown to make the platform strong enough for mounting.
2. Drill the four marked holes with a suitable drill bit, making sure to keep the drill perpendicular to the platform's surface.
3. Mount the ladder to the platform with fasteners suitable for your particular installation.
4. Periodically check fasteners for tightness and polish the stainless steel with a suitable marine grade polish to increase longevity.

Fold ladder up and secure when underway.

MAINTENANCE

- **Keep that bright finish!**
Local weather conditions may contribute to minor corrosion. Stainless, like other metals, is not completely free from corrosion attack. Regular fresh water rinsing and periodic cleaning with a mild abrasive cleaner will help to retain lustre.

- **Safety tip**
Periodically check mounting hardware and re-tighten (due to normal boat operation.)

SAFETY GUIDELINES

- No jumping or diving!
- Do not use when motor is running
- This ladder designed for boat use only
- Face ladder when entering boat or water
- Only one person on ladder at a time
- Check all steps and hardware before using
- Never operate your boat with the ladder in "down" position. Serious injury, or damage to your boat or ladder may result.

Figure 1
FASTENER
SUGGESTION

Note:

Fasteners
and backing
plate not
provided

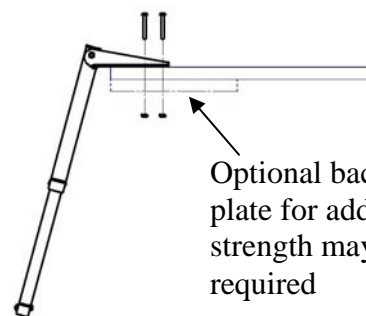

Optional backing
plate for added
strength may be
required

Ladder ships with RE-USEABLE securing strap holding ladder in stowed position.

DO NOT CUT!

To STOW ladder



To DEPLOY ladder

