



Installation and Operating Instructions for Model 20000/20001/21000/ 21001/22000 Seat Slide System

INSTALLATION

Read instructions completely before installing. Refer to Fig. 1.

1. Position Seat Slide on seat bottom and align 4 mounting holes.
2. Secure Seat Slide with appropriate hardware.

NOTE: Fasteners are not provided due to the wide variety of installations.

NOTE: All EEz-In seats use 1/4"-20 threaded T-nuts.

SPECIAL NOTE: for rotational molded EEz-In seats:

- A. Remove the reinforcement brackets from the seat bottom prior to installation.
- B. Make certain that the portion of the screw entering the seat shell's T-Nut does not exceed 3/8". Seat shell T-nuts are 1/4"-20 thread, use only 1/4"-20 machine screws.

3. Remove black delrin cup from swivel casting. Align splines in cup with splines on seat pedestal and tap on with a soft hammer, if necessary.
4. Slip seat with slide onto pedestal.

SMOOTH TUBE INSTALLATION

Read instructions completely before installing. Refer to Fig. 2.

1. Slide Delrin Cup (59.858) over stanchion tube. Align one of three countersunk holes to front of the tube. This will index casting so seat will lock in the forward facing position. Push down until rim of cup contacts top of tube. Center punch tube at locations of three countersunk holes.
2. Drill three holes 13/64" diameter through tube. File or scrape clean the burrs left from drilling.
3. Fasten cup in place using three flathead screws (03.547) and locknuts (03.027).

99301 INSTALLATION INSTRUCTIONS

Read instructions completely before installing. Refer to Fig. 1.

1. Mount the seat and slide assembly on the pedestal. Slip 06.045 cup catch over rib in the casting directly under the cam handle. Secure with 10-24 x 3/4" screw and locknut.

(continued on back)

FIG. 1

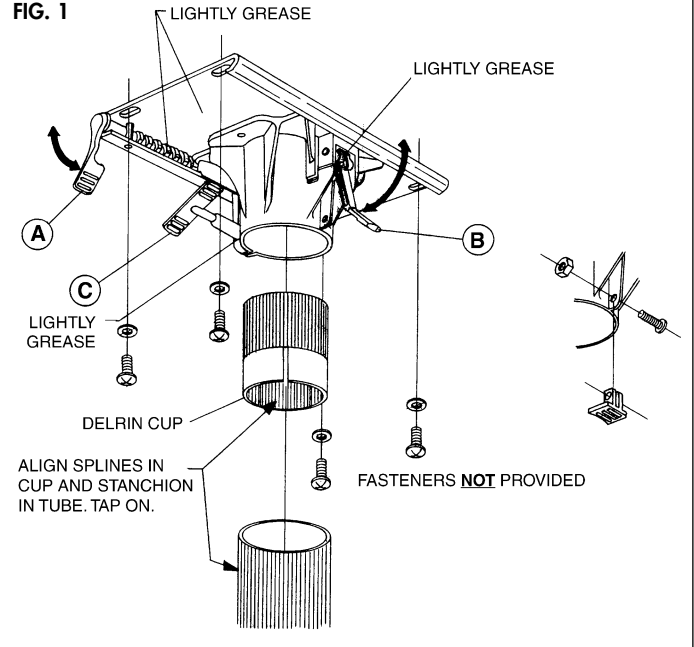
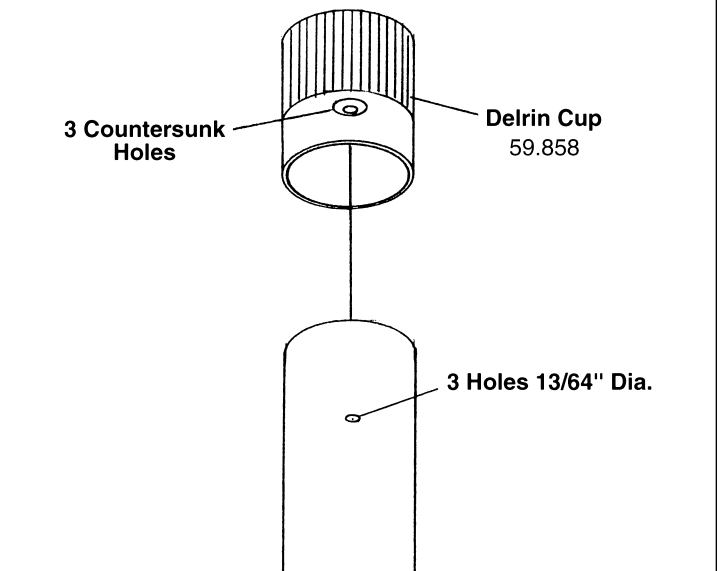

FIG. 2



Installation and Operating Instructions – Model 20000/20001/21000/21001/22000 Seat Slide System

(continued)

SMOOTH DELRIN CUP INSTALLATION FOR ADJUSTABLE HEIGHT SEAT BASES MODELS 75436/75437

Refer to Fig. 3.

1. Align 2 of the 3 countersunk holes in the Delrin cup (59.858) as shown in figure 3. This will allow clearance of the screws and nuts with the ribs on the inside wall of the stanchion. Mark the 2 locations and remove the cup.
2. Center punch the 2 marks. With a 13/64" bit, drill 2 holes through.
3. Fasten cup in place using 2 flat head screws (03.547) and 2 locknuts (03.027).

NOTE: After assembly and installation of the seat is complete, check to see if the seat will lock in the forward facing position. If the seat locks slightly left or right of perfectly forward, it may be necessary to rotate the base slightly to achieve the ability to lock your seat straight forward.

FIG. 3

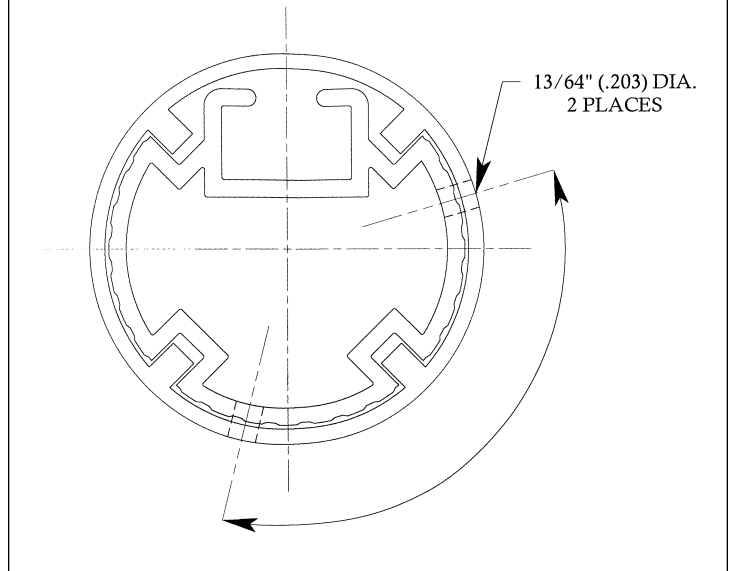

TO OPERATE

1. To adjust fore and aft seat position, pull up on Handle "A", slide seat to desired position and release handle. Slide will lock into position.
2. To rotate seat and adjust the drag control feature for rotation, pull Handle "B" up to the horizontal position and release. The handle will maintain the horizontal position. The seat is now free to rotate 360 degrees. To increase the drag on rotation, turn Handle "C" clockwise to desired resistance. To decrease drag, turn Handle "C" counter-clockwise.
3. To positive lock the rotational feature, push Handle "B" down and the Positive Quick Lock feature hunts for the next available locking spline.

NOTE: Always use positive lock feature when boat is underway.

MAINTENANCE

Keep a light film of grease on:

- Slide plate surface that the casting slides on
- The multiple cam surfaces that the casting locks into
- The Cam Surface on the Bottom of Handle "B" that is exposed when in the horizontal position
- The Stainless Steel bolt that Handle "C" is threaded onto

Periodically check and tighten the mounting screws between the seat slide and the seat bottom.