

INSTRUCTION SHEET: EuroLED® 75 LED Interior / Exterior Downlight

EuroLED® lamps offer many advantages over incandescent lighting including significantly reduced power consumption, reduced heat and a high resistance to shock, vibration and moisture for long service life in the harsh marine environment.

Product specifications:

Light Source	LED
Colour Temperature	5000K White / 2700K Warm White
Operating Voltage	12V DC or 24V DC Depending on model
Power Consumption	<3W (<0.19A @ 12V DC / <0.1A @ 24V DC)
Cable	Pre-wired with 150mm tinned marine cable
Dimming	with PWM Dimmer (e.g. via Hella marine 5XA 998 572-001)
Mounting type	Screw or Spring Depending on model
Degree of Protection	IP6K7 & IP6K9K (Completely sealed)
Weight	Screw mt: 44g Plastic Rim / 50g Stainless Rim (including cable) Spring mt: 50g Plastic Rim / 56g Stainless Rim (including cable)



Electromagnetic Compatibility (EMC)

This LED lamp is an electronic device. The electrical circuits contain components that suppress possible interference, both emission as well as susceptibility, to the limits prescribed in international regulations (EN60945, IEC61547, CISPR15).

Wiring and Electrical Protection

LED modules are polarity conscious. This lamp is protected against reverse polarity connection, reverse polarity will not damage this product but will inhibit its function.

HELLA marine recommends wire connections be soldered, and heat shrink tubing applied to seal the joint. Each lamp must be protected against short circuit by a suitably rated fuse.

Colour	Connect to	Power
Black	Negative (-ve)	
White or White/Yellow	Positive (+ve)	<3W

Mounting Instructions

Ensure the lamp is mounted on a flat surface. For screw mounting the Pitch Circle Diameter for the mounting holes should be 57mm (2.24"). Screw mount lamps are provided with a gasket. Mount the lamp and fit lamp bezel to lens.

Note: This lamp is fully sealed and has no serviceable components.

Dimensions:

- a = 72.0mm (2.83") with stainless rim
75.0mm (2.95") with plastic rim
- b = 50.0mm (1.96") with screw mounting
54.0mm (2.12") with spring mounting
- c = 16.0mm (0.63") with screw mounting
20.5mm (0.81") with spring mounting
- d = 7.5mm (0.29")
- e = 57.0mm (2.24") PCD

Screw Mount

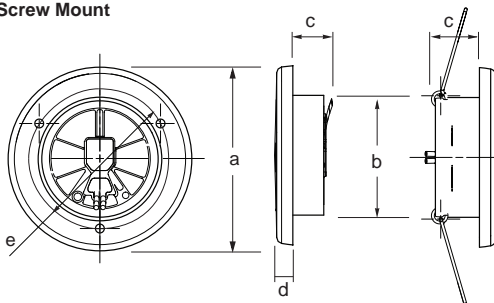

Spring Mount

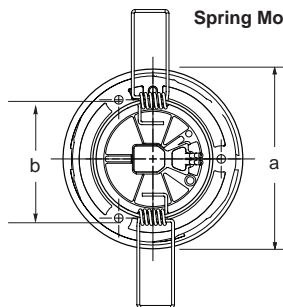

Warranty

Congratulations! The product you have selected comes from HELLA – one of the world's leading manufacturers of lighting products. The product comes with a 5 year warranty from end user purchase covering faults in materials, components or workmanship.

In the unlikely event that you should experience a confirmed warranty related problem with your purchase, HELLA will, at its discretion, either repair, replace or refund the purchase price of the product. Warranty services may be obtained by returning the product within the warranty period to the HELLA dealer where the product was originally purchased.

This warranty is in addition to and does not preclude any other rights or remedies available to the consumer under any local legislation related to the provision of goods or services.

Our goods come with guarantees that cannot be excluded under the Australian Consumer Law. You are entitled to a replacement or refund for a major failure and for compensation for any other reasonably foreseeable loss or damage. You are also entitled to have the goods repaired or replaced if the goods fail to be of acceptable quality and the failure does not amount to a major failure.

This warranty does not cover:

1. Claim/s as a result of normal wear and tear or of any modifications and / or alterations to the product in any shape or form.
2. Claim/s as a result of non-compliance of the assembly, service and operating instructions and/or any unfit or improper use.
3. Any expenses incurred in the process of making the claim.