



**NAViLED®Trio 2NM Tri-Colour Navigation Lamp  
with All Round White / Anchor Lamp**

**Introduction**

Hella marine LED Navigation Lamps offer many advantages over conventional bulb lamps. Significantly reduced power consumption, ultra long life and high tolerance to shock and vibration make Hella marine LED lamps the ideal choice for the harsh marine environment.

Hella Marine LED navigation lamps are 'Precision Optical Instruments', tested and type approved to comply with international maritime regulations.

The Hella marine LED Tri-Colour employs a unique installation method. The completely sealed Light Engine is installed over the stainless steel Mounting Shaft and secured with a nut for easy removal and re-installation.

**Correct Positioning and Operation**

According to international maritime regulations, a Tri-Colour lamp ;

May only be carried by a sailing vessel of less than 20 meters (65 ft.) in length.

Must be carried at or near the top of the mast where it can best be seen.

Must not be displayed when the vessel is under power, or when under sail and power.  
( Under these conditions the configurations for power driven vessels apply. )

Must be switched so one switch, or position of a switch, shall display the complete Port, Starboard and Stern navigation light configuration as required for the vessel when underway.

Another switch, or switch position, shall display the all Round White / Anchor lamp only.

When the lamp(s) operate, the light should not be obstructed or concealed by masts, topmasts or structures.

As close as practicable to the fore and aft centre line of a vessel.

**International Approvals**

Hella marine LED Tri-Colour lamps are tested and type approved to comply with international maritime regulations.

Approval Type      BSH  
Length (LOA)        Sailboats up to 20 meters / 65 feet in length.

Additional Approval      USCG / IMO COL REG  
Length (LOA)            Sailboats up to 20 meters / 65 feet in length.

Approval Type        ABYC and NMMA  
Length (LOA)         Sailboats up to 20 meters / 65 feet in length.



**Specifications**

<b>Lamp Base Material</b>	UV resistant, high impact nylon
<b>Light Engine Lens Material</b>	UV resistant, ultra heavy duty Grilamid
<b>Mounting Shaft Material</b>	316 stainless steel
<b>Minimum Visible Distance</b>	2 Nautical Miles (Yacht)
<b>Light Source</b>	LED
<b>Installation</b>	Pre-wired with 400mm of triple core marine cable.
<b>Operating Voltage</b>	Multivolt™ 9-33V DC
<b>Voltage Protection</b>	Spike protected to +500 volts Reverse polarity protected to -700 volts
<b>Power Consumption</b>	Port, Starboard, Stern less than 3.5W combined All Round White / Anchor less than 1.5W
<b>Degree of Protection</b>	IP 67 - Completely sealed
<b>Weight</b>	400g (including cable)

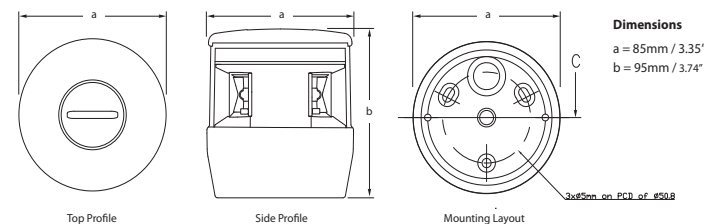

**Electromagnetic Compatibility (EMC)**

This LED lamp is an electronic device. The electrical circuits contain components that suppress possible interference, both emission as well as susceptibility, to the limits prescribed in EN 60945.



**Protection against damage due to voltage spikes**

This lamp is protected against reverse polarity connection and negative voltage spikes of up to 700 volts.

**7 Year Manufacturers Warranty**

**Congratulations! The product you have selected comes from Hella marine - one of the world's leading manufacturers marine lighting products.**

This NavILED®Trio LED Tri-Colour lamp is covered by a 7 year manufacturers warranty against manufacturing or material defects. For further details please check the terms of trade with your Hella marine agent.

The lamp module is sealed and does not have any serviceable parts inside; opening the module will invalidate warranty.

In the unlikely event that you should experience a problem with your purchase, please contact your Hella marine agent where you purchased the product.



### Pre Installation

Remove lamp from packaging. Note the components illustrated in Fig 4.

- 1.1 Remove lamp Top Cap. Quarter turn clockwise to unlock.
- 1.2 Remove the Plastic Transit Nut and Washer. (M12 Nyloc Nut is supplied for installation)
- 1.3 Slide the Light Engine off the Mounting Shaft.

### Installation

#### Step 1 - Lamp positioning holes.

1.1 Make provision for installation holes in the top of the mast ensuring that once installed, the rubber Cable Grommet will face directly Aft and the 4mm round hole in the Lamp Base will face directly Forward. (see Fig 1)

Use Lamp Base as a mounting template.

Mounting hole layout is identical to Hella marine 2984 series Tri-Colour and All Round White / Anchor lamps.

Cable Grommet hole and single round hole in Lamp Base must be positioned parallel with the vessels centre line.

**Do not fasten Lamp Base to the mast. Perform Step 2 then fasten Lamp base and Mounting Shaft components together in Step 3.**

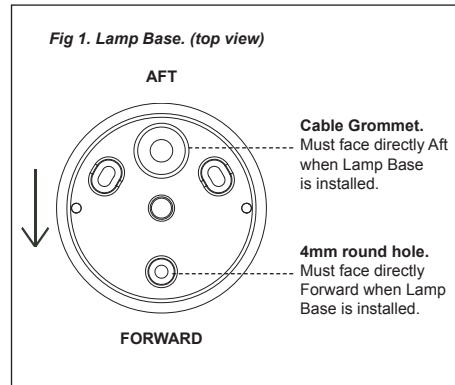

#### Step 2 - Connect cable to vessel's power supply.

2.1 Pass the cable end through the Cable Grommet hole in the Lamp Base so the Superseal Connector can be positioned inside the Lamp Base. (see Fig.2)

2.2 Connect the cable to the vessel's Tri-Colour and Anchor lamp circuits as per the Wiring Colour Code below.

Hella marine recommends the use of heat shrink glue joiners for reliable electrical connections.

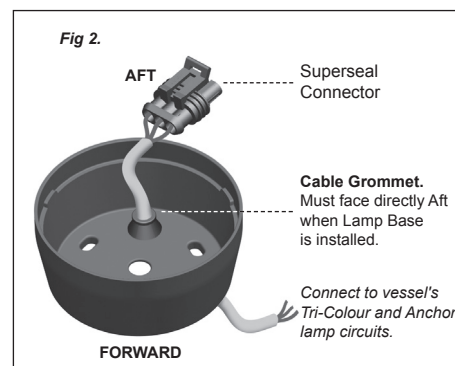

### Wiring Colour Code

LED modules are polarity conscious. Reverse polarity will not damage this product but will inhibit its function. Hella marine recommends wire connections be soldered, and heat shrink tubing applied to seal the joint.

Colour	Connect to	Power	Function
Black	Negative (-ve)		
Red	Positive (+ve)	<4W	Port / Starboard / Stern
Blue	Positive (+ve)	<2W	Anchor

- Supply Voltage 8-28V (DC only)

NB: Lamp must be protected by a fuse rated at 5 amperes maximum.

### Step 3 - Install Lamp Base and Mounting Shaft.

Place the Mounting Shaft inside the Lamp Base and fasten both components to the top of the mast. (see Fig.3)

Superseal Connector must sit in forward half of the Lamp Base with the cable positioned on the Starboard side of the mounting Shaft.

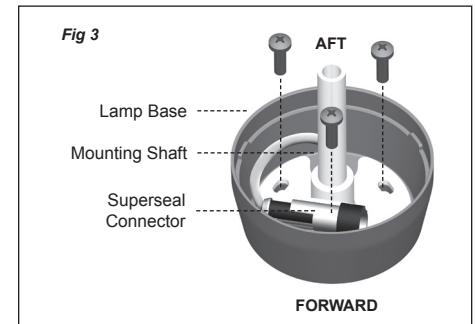

### Step 4 - Install Light Engine (see Fig.4)

4.1 Connect the Superseal Connector.

4.2 Hold the Light Engine so the Stern Light sector faces aft.

Slide the Light Engine over the mounting shaft and rotate until the unit locates on the edges of the Lamp Base.

**Once in position, arrow on top of Light Engine will point directly ahead.**

4.3 Install the M12 Nyloc Nut and Plastic Washer to secure the Light Engine. (Nyloc Nut supplied in plastic bag)

**Nyloc Nut requires a maximum torque of 10Nm (7.38 ft/lbs) to secure the Light Engine.**

**Do not over-tighten.**

Install Top Cap.  
Quarter turn anti-clockwise to lock.

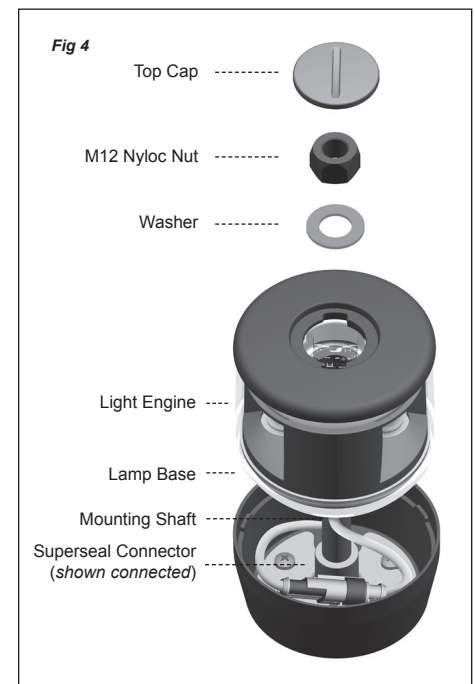

### Light Engine Removal

- 1.1 Remove Top Cap. Quarter turn clockwise to unlock. Lever out Top Cap with small flat blade.
- 1.2 Remove the M12 Nyloc Nut and Washer.
- 1.3 Slide the Light Engine unit off the Mounting Shaft.
- 1.4 Disconnect the Superseal Connector.