

Correct Positioning

NaviLED®360 Compact All Round / Anchor Lamps must be installed as follows:

When the lamp operates, the light should not be obstructed or concealed by masts, topmasts or structures, i.e. Installed on the highest point of a vessel so the light arc is unbroken.

All Round lamps must be positioned as close as practicable to the fore and aft centre line of a vessel. (see Fig. 1)

The All Round white lamp on a power driven Vessel less than 12m in length shall be installed at least one meter higher than the sidelights.

The lamp must be installed so that the horizontal surface of the base is parallel to the vessel's water line. (See Fig.2)

Fig. 1 On the fore and aft centre line.

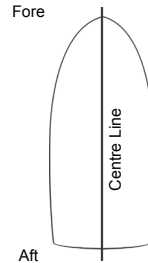
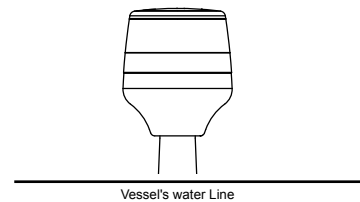
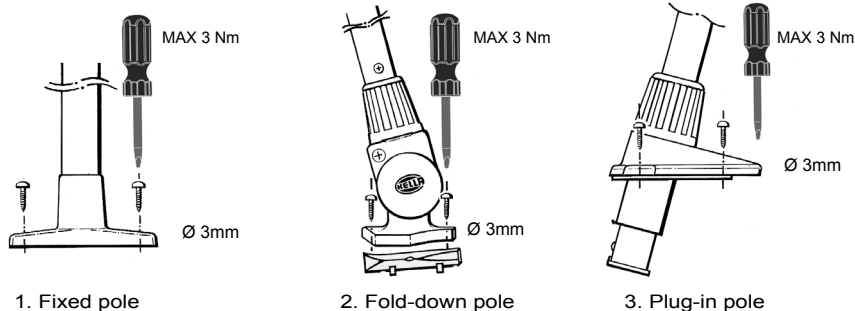

Fig. 2 Installed with base parallel to vessel's water line.



Installation Instructions

- Fixed Pole mount:** Ensure mounting surface is flat and on the vessels centre line (see above). Use the provided screws to secure taking care not to over tighten.
- Fold-down Pole mount:** A removable wedge is supplied for installations onto different surface cambers. Use the provided screws to secure taking care not to over tighten. Once mounted the base can be adjusted through 180 degrees, when the desired angled is reached secure by tightening the locking collar.
- Plug-in Pole mount:** Mount base separately and connect wiring. Use the provided screws to secure taking care not to over tighten. Insert lamp into base and fix with locking collar. Ensure rubber cap, as provided, is used to cover socket when pole is removed.



NAILED®360

Hella marine HELLA
Vision and Innovation

INSTRUCTION SHEET: NaviLED®360 Compact Pole Mount 2 Nautical Mile All Round White / Anchor Lamp

Hella marine LED Navigation Lamps offer many advantages over conventional bulb lamps. Significantly reduced power consumption, ultra long life and high tolerance to shock and vibration make the LED lamps the ideal choice for the harsh marine environment.

The Hella marine NaviLED®360 series are Precision Optical Instruments, tested and type approved to comply with international maritime regulations. They are covered by a 5 year warranty.

Product Specifications

Housing Material	UV resistant high impact plastic
Lens Material	Heavy duty Grilamid®
Minimum Visible Distance	2 Nautical Miles
Cable	Pre-wired with twin core marine cable
Operating Voltage	Multivolt™ 9-33V DC
Power Consumption	Less than 1W (0.08A @ 12V / 0.04A @ 24V)
Degree of Protection	IP 67 - Completely Sealed
Approvals	USCG, IMO COL REG 72, Wheelmark



Electromagnetic Compatibility (EMC)

This LED lamp is an electronic device. The electrical circuits contain components that suppress possible interference, both emission as well as susceptibility, to the limits prescribed in international regulations.

Wiring Colour Coding

Colour	Connect to
Black	Negative (-ve)
Red	Signal (+ve)

Wiring and Electrical Protection

LED modules are polarity conscious. This lamp is protected against reverse polarity connection, reverse polarity will not damage this product but will inhibit its function. HELLA marine recommends wire connections be soldered, and heat shrink tubing applied to seal the joint.

Each lamp must be protected against short circuit by a fuse rated at 5 amperes maximum.

Note: Do not attempt to open, no serviceable part inside.

Designed and Manufactured in New Zealand



Warranty

Congratulations! The product you have selected comes from HELLA – one of the world's leading manufacturers of lighting products. The product comes with a 5 year warranty from end user purchase covering faults in materials, components or workmanship.

In the unlikely event that you should experience a confirmed warranty related problem with your purchase, HELLA will, at its discretion, either repair, replace or refund the purchase price of the product. Warranty services may be obtained by returning the product within the warranty period to the HELLA dealer where the product was originally purchased.

This warranty is in addition to and does not preclude any other rights or remedies available to the consumer under any local legislation related to the provision of goods or services.

Our goods come with guarantees that cannot be excluded under the Australian Consumer Law. You are entitled to a replacement or refund for a major failure and for compensation for any other reasonably foreseeable loss or damage. You are also entitled to have the goods repaired or replaced if the goods fail to be of acceptable quality and the failure does not amount to a major failure.

This warranty does not cover:

1. Claim/s as a result of normal wear and tear or of any modifications and / or alterations to the product in any shape or form.
2. Claim/s as a result of non-compliance of the assembly, service and operating instructions and/or any unfit or improper use.
3. Any expenses incurred in the process of making the claim.

NaviLED®360 Integrated Timer

To ensure long term safety, this NaviLED®360 lamp is equipped with a timing circuit.

Once the lamp has operated for a total time of 10,000 hours, the lamp activates 'Service Mode'.

Service Mode is indicated by the lamp flashing at a rate of 60 flashes per minute for 15 seconds as soon as the lamp is switched on. This will occur for 15 seconds every time the lamp is switched on until the unit has operated for another 2000 hours.

After 2000 hours the Service Mode flash rate doubles to 120 flashes per minute for 15 seconds as soon as the lamp is switched on.

To ensure the lamp meets the light output criteria of its certification, Hella marine recommends the lamp be replaced as soon as it enters this 2000 hours Service Mode stage.

By normal recreational boating standards, even with regular night sailing, 'Service Mode' will hardly ever be reached.