



TRANSOM TRANSDUCER Installation Guide

532508-4_A

The transom mount installation allows adjustment of both running angle and depth after the transducer is mounted, which enables you to tune the installation for best results. It is important to read the instructions completely and understand the mounting guidelines before beginning this installation.

 **NOTE:** Due to the wide variety of hulls, only general instructions are presented in this guide. Each boat hull represents a unique set of requirements that should be evaluated prior to installation. For detailed information about installing transducers on different hull types, download the Transducer Installation Resource Guide from our Web

 **NOTE:** Your transducer may not look exactly like the transducer shown in the illustrations, but it will mount in exactly the same way.

INSTALLATION PREPARATION

Install the control head before you start the transducer installation. See the control head installation guide.

Review your boat manufacturer's owner's manual for recommended transducer installation locations and cable routing methods, as well as your transom and/or deadrise angle.

Read and understand your boat's warranty before starting this installation.

Visit our Web site for additional information and resources for transducer installations.

Confirm your boat is level for the installation.

Consider your speed requirements.

Traveling over 65 mph with the transducer in the water is not recommended with the transom mount transducer, as damage may occur. If speed above 65 mph is critical, see the FAQ (Frequently Asked Questions) section of our Web site

Supplies: In addition to the hardware supplied with your transducer, you will need a powered hand drill and various drill bits, various hand tools, including a ruler or straightedge, a level, marker or pencil, Phillips-head screwdriver, flat head screw driver, a socket/nut driver, a 1/2" [13 mm] wrench and torque wrench, safety glasses and dust mask, marine-grade silicone sealant, and dielectric grease (optional). You may also need extension cables and hardware for routing the cable to the control head.

INSTALLATION OVERVIEW

New Installation: Review *Turbulence-Free Mounting Guidelines* and proceed to section **1. Mount the Transom Bracket to the Boat.**

Previously-installed Transducer: If you have a previously-installed XHS transducer on the transom, the bracket in this installation kit can be installed in the same location using the following instructions:

1. Line up the metal bracket with the previously-used mounting holes to confirm that the two slot holes match the previous installation. Fill any unused holes with marine-grade silicone sealant.

TRANSOM TRANSDUCER Installation Guide

532508-4_A

2. Make sure the boat is level on the trailer (from port to starboard and from bow to stern).
3. Proceed to section **2. Install the Transducer.**

TURBULENCE-FREE MOUNTING GUIDELINES

It is very important to locate the transducer in an area that is relatively free of turbulent water. Consider the following to find the best location with the least amount of turbulence:

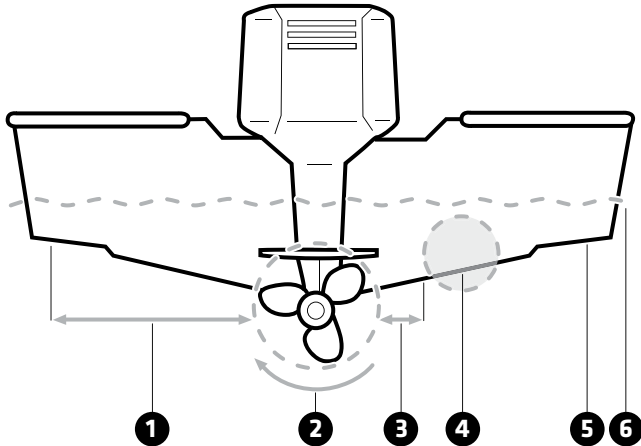

- 1** **Avoid areas where there is turbulent water flow.** Turbulent water is normally confined to areas immediately aft of ribs, strakes, or rivets on the bottom of the boat, and in the immediate area of the propeller[s]. The best way to locate turbulence-free water is to view the transom while the boat is moving.
- 2** **Observe your propeller's direction of rotation** (in forward, as you're facing the stern of the boat from behind). Clockwise propellers create more turbulence on the port side. Counterclockwise propellers create more on the starboard side.
- 3** **Ensure there is adequate distance from the propeller[s].** On outboard or inboard/outboard boats, it is best to locate the transducer at least 15" (38.1 cm) to the side of the propeller[s].
- 4** **The ideal mounting location [right of the propeller[s]].** It is important to note that if you plan to trailer your boat, do not mount the transducer too close to trailer bunks or rollers to avoid moving or damaging the transducer during loading and unloading of the boat.
- 5** **For boats with stepped hulls,** it may be possible to mount the transducer on the step. Do not mount the transducer on the transom behind a step to avoid popping the transducer out of the water at higher speeds.
- 6** **The transducer must be mounted so that it is parallel with the waterline, but fully submerged in the water during operation.**
- 7** **If you have a Side Imaging® transducer,** the transducer must NOT have anything obstructing the 'view' of the side looking beams. For example, nothing can be in the line of sight of these beams [not a hull, motor, or other transducer, etc.]

 **NOTE:** You may need to tilt the motor up and out of the way when using the side looking beams.

Deadrise: The hydrodynamic shape of your transducer allows the sonar beams to point down without deadrise adjustment.

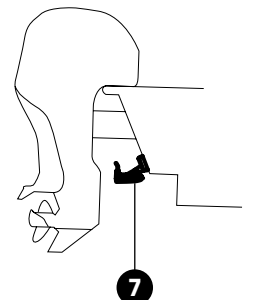

Unobstructed View: This jack plate installation gives the transducer safe distance from the motor and turbulence. The Side Imaging has a clear view side-to-side.

1 | Mount the Transom Bracket to the Boat

1. Confirm the boat is level on the trailer (both from port to starboard and from bow to stern).
2. Hold the mounting bracket against the transom of the boat in the location you have selected. Align the bracket horizontally, using the level. Make sure that the lower corner of the bracket does not protrude past the bottom of the hull.

If your propeller moves clockwise as the boat moves forward (as you're facing the stern of the boat from behind), mount the transducer on the starboard side. If your propeller moves counterclockwise as the boat moves forward (as you're facing the stern of the boat from behind), mount the transducer on the port side.

Using the Mounting Bracket to Mark the Drill Holes

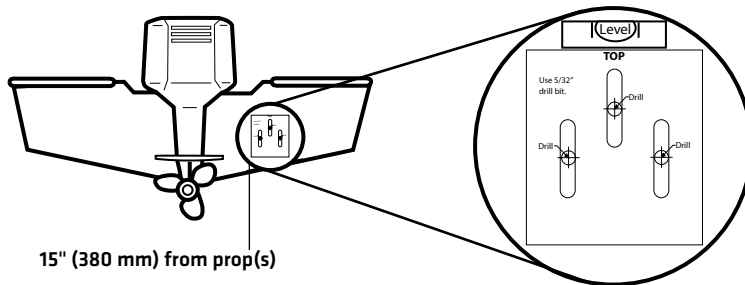

15" (380 mm) from prop(s)

3. Continue to hold the bracket on the transom of the boat, and use a pencil or marker to mark where to drill the three mounting holes. Mark the drill holes near the top of each slot, making sure that your mark is centered in the slot.
4. Make sure the drill bit is perpendicular to the actual surface of the transom, NOT parallel to the ground, before you drill.

Using a 5/32" [4.0 mm] bit, drill the three holes to a depth of approximately 1" [25 mm].

NOTE: On fiberglass hulls, it is best to use progressively larger drill bits to reduce the chance of chipping or flaking the outer coating.

5. Use a marine-grade silicone sealant to fill the drilled holes.
6. Align the transom bracket with the mounting holes. The center slot should be above the two outer slots. Confirm the bracket is level.
7. Using a hand socket/nut driver, install the three #10-1" [25 mm] screws into the drilled holes, but **do not tighten completely**.

NOTE: Make sure the mounting screws are snug, but do not fully tighten the mounting screws at this time to allow the transducer assembly to slide for adjustment purposes.

2 | Install the Transducer

The transom bracket allows you to adjust the height, and the pivot bolts allow you to adjust the angle of the transducer. These adjustments help reduce cavitation and air bubbles around the transducer during operation.

1. Align the transducer bracket with the holes on top of the transducer.
2. Use a Phillips-head screwdriver to install a 7/16" [11 mm] screw and #8 split ring lock washer into each bracket hole (6 holes total). Hand tighten each screw until each split ring lock washer flattens. **Hand tighten only.**
3. Align the holes on the transducer bracket with the holes on the transom bracket.

Attaching the Bracket to the Transom

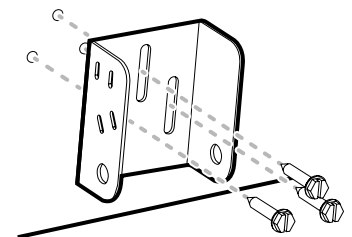

TRANSOM TRANSDUCER Installation Guide

532508-4_A

- Install the pivot bolt, 2 washers, and lock nut into the first hole as shown in the illustration *Installing the Transducer Bracket*. Repeat for the second hole.
- Use a 1/2" [13 mm] wrench to tighten the assembly, but do not fully tighten the hardware at this time [so you can make adjustments if needed after testing the installation].

Installing the Transducer Bracket

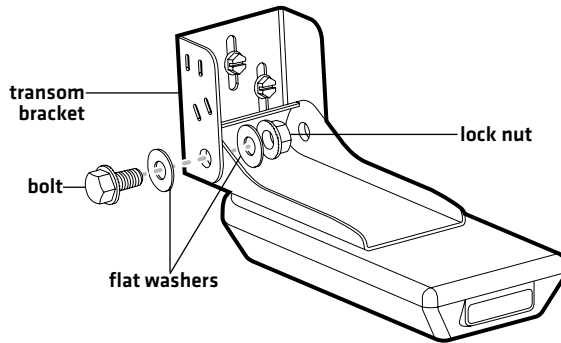

3 | Confirm the Mounting Angle

You will need to adjust the initial angle of the transducer both vertically and horizontally to confirm the transducer mounting angle.

- Confirm the height of the transducer is high enough on the transom so it is out of the jet stream when the boat is on plane and that it will be submerged in the water during trolling speeds.

To adjust the height, loosen the screws slightly in the transom bracket, and slide the bracket up or down using the slots. If you cannot access the screws, you may need to uninstall the transducer, adjust the height, and repeat the installation instructions in sections 1 and 2.

- Adjust the angle of the transducer**, so it is parallel with the length of the boat hull, with a slight down angle [approximately 5 degrees].

Adjusting the Transducer Running Angle

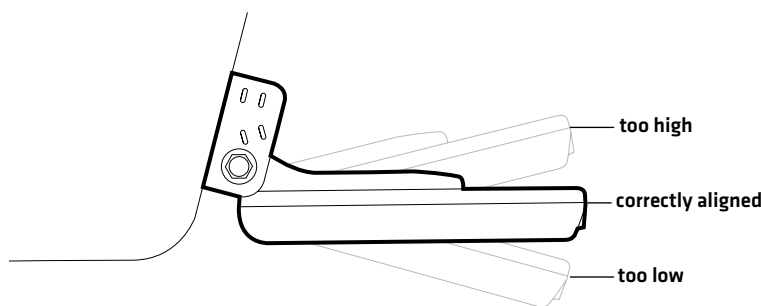

- Hand tighten the two pivot bolts, using a 1/2" [13 mm] wrench.



NOTE: You will finalize the installation after you route the cable and test the installation in the following procedures.

4 | Route the Cable

You can route the cable **over the transom** or **through a hole in the transom above the waterline**. Your boat may have a pre-existing wiring channel or conduit that you can use to route the cable. Select the routing method that is best for your boat configuration, and purchase any extension cables, cable clips, clamps, etc. as needed.

- It is best to route the cable to the side of the transducer so the transducer will not damage the cable during movement.

Attaching the Transducer Bracket

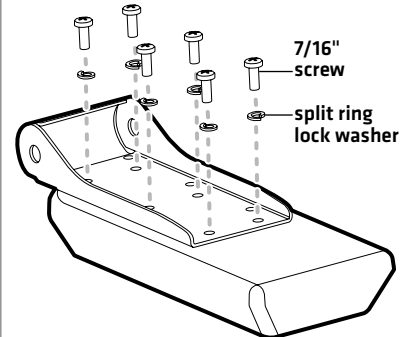

Adjusting the Height

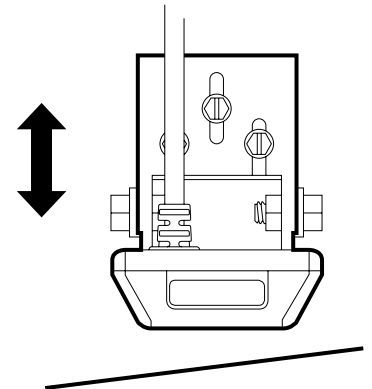

Leveling the Bracket

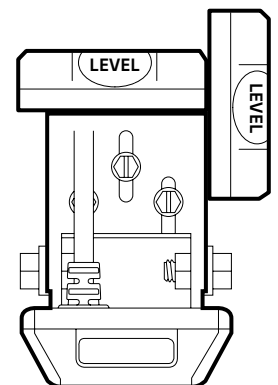

TRANSOM TRANSDUCER Installation Guide

- The transducer can pivot up to 90 degrees in the bracket. Allow enough slack in the cable for this movement.
- If you drill any holes, fill them with marine-grade silicone sealant.
- **Excess Cable:** If there is excess cable that needs to be gathered at one location, dress the cable routed from both directions so that a single loop is left extending from the storage location. Doubling the cable up from this point, form the cable into a coil. Storing excess cable using this method can reduce electronic interference.

⚠ CAUTION! Do not cut or shorten the transducer cable, and try not to damage the cable insulation. Route the cable as far as possible from any VHF radio antenna cables or tachometer cables to reduce the possibility of interference. If the cable is too short, extension cables are available to extend the transducer cable up to a total of 50'. For assistance, contact Humminbird® Technical Support.

⚠ CAUTION! Do NOT mount the cables where the connectors could be submerged in water or flooded. If cables are installed in a splash-prone area, it may be helpful to apply dielectric grease to the inside of the connectors to prevent corrosion. Dielectric grease can be purchased separately from a general hardware or automotive store.

5 | Connect the Cable

1. Connect the transducer cable to the transducer port on the control head or cable connector (if applicable).

The connector is keyed to prevent reversed installation, and insertion should be easy. Do not force the connectors into the ports.

If the cable connector is round, hand-tighten the screw nut to secure the cable connection. **Hand-tighten only!**

Refer to your control head installation guide for additional details.

6 | Test and Finish the Installation

Once you have installed the control head, the transducer, and have routed all the cables, you must perform a final test before locking the transducer in place.

Testing should be performed with the boat in water deeper than 2 feet. The transducer should be fully submerged because the sonar signal cannot pass through air.

⚠ WARNING! The transducer must be fully submerged in water during operation because the sonar signal cannot pass through air. Air pinging can damage the transducer.

Test the Transducer Installation on the Control Head

1. Press the POWER key to turn on the control head.
If the transducer is detected, the control head will start Normal mode.
2. Select a Sonar View to display on-screen.
HELIX®: Press and hold the VIEW key. Select Sonar > Sonar View.
SOLIX®: Press the HOME key. Select a 2D Sonar View.
Other: See your control head operations manual.
3. If the bottom is visible on-screen with a digital depth readout, the unit is working properly.
4. **2D Sonar Test:** If the unit is working properly, gradually increase the boat speed to test high-speed performance.
5. Review the sonar returns displayed on the [2D] Sonar View. If the unit functions well at low speeds, but begins to skip or miss the bottom at higher speeds, the transducer requires adjustment.

Routing the Cable

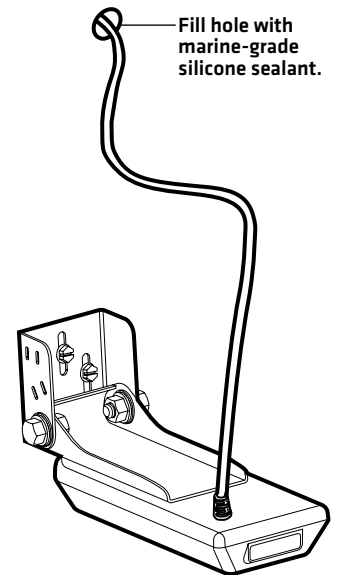

Transducer Connectors

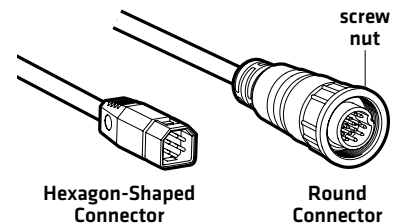

TRANSOM TRANSDUCER Installation Guide

CAUTION! If you do change the transducer position, re-trace the position of the mounting bracket before proceeding.

6. **Side Imaging® Test:** Select a Side Imaging View.
HELIX: Press and hold the VIEW key. Select Sonar > Side Imaging View.
SOLIX: Press the Home key. Select a Side Imaging View.
Other: See your control head operations manual.
7. Navigate the boat in a straight line at trolling speed. Confirm there is nothing obstructing the display of the side imaging beams.

Finalize the Transducer Installation

Once you have reached a consistently good sonar signal at the desired speeds, you are ready to lock down the transducer settings.

8. Confirm the transom bracket is level and hand tighten the screws until they are secure. **Hand tighten only!**
 Fully tighten the two pivot bolts, using a 1/2" [13 mm] torque wrench to 12 ft-lbs. If you don't have a torque wrench, use a crescent/box wrench to hand tighten the two pivot bolts until they are secure, then turn the wrench 45 to 60 degrees more. **Hand tighten only!**

MAINTENANCE

If your transducer remains in the water for long periods of time, slush, algae and other marine growth can reduce the effectiveness of the transducer. Periodically clean the face of the transducer with a mild, marine-safe and plastic-safe soap or solution.

If your transducer remains out of the water for a long period of time, it may take some time to wet the transducer after it is returned to the water. Small air bubbles can cling to the surface of the transducer and interfere with proper operation. These bubbles will dissipate with time, or you may wipe the face of the transducer with your fingers after the transducer is in the water.

WARNING! Disassembly and repair of this electronic unit should only be performed by authorized service personnel. Any modification of the serial number or attempt to repair the original equipment or accessories by unauthorized individuals will void the warranty.

WARNING! The transducer must be fully submerged in water during operation because the sonar signal cannot pass through air. Air pinging can damage the transducer.

NOTE: Download Humminbird installation guides and operations manuals from our Web site

NOTE: Product specifications and features are subject to change without notice.

ENVIRONMENTAL COMPLIANCE STATEMENT: It is the intention of Johnson Outdoors Marine Electronics, Inc. to be a responsible corporate citizen, operating in compliance with known and applicable environmental regulations, and a good neighbor in the communities where we make or sell our products.

WEEE DIRECTIVE: EU Directive 2002/96/EC "Waste of Electrical and Electronic Equipment Directive [WEEE]" impacts most distributors, sellers, and manufacturers of consumer electronics in the European Union. The WEEE Directive requires the producer of consumer electronics to take responsibility for the management of waste from their products to achieve environmentally responsible disposal during the product life cycle.

WEEE compliance may not be required in your location for electrical & electronic equipment (EEE), nor may it be required for EEE designed and intended as fixed or temporary installation in transportation vehicles such as automobiles, aircraft, and boats. In some European Union member states, these vehicles are considered outside of the scope of the Directive, and EEE for those applications can be considered excluded from the WEEE Directive requirement.



This symbol [WEEE wheelee bin] on product indicates the product must not be disposed of with other household refuse. It must be disposed of and collected for recycling and recovery of waste EEE. Johnson Outdoors Marine Electronics, Inc. will mark all EEE products in accordance with the WEEE Directive. It is our goal to comply in the collection, treatment, recovery, and environmentally sound disposal of those products; however, these requirements do vary within European Union member states. For more information about where you should dispose of your waste equipment for recycling and recovery and/or your European Union member state requirements, please contact your dealer or distributor from which your product was purchased.