

TRANSDUCER RESOURCE GUIDE

532651-1EN_A

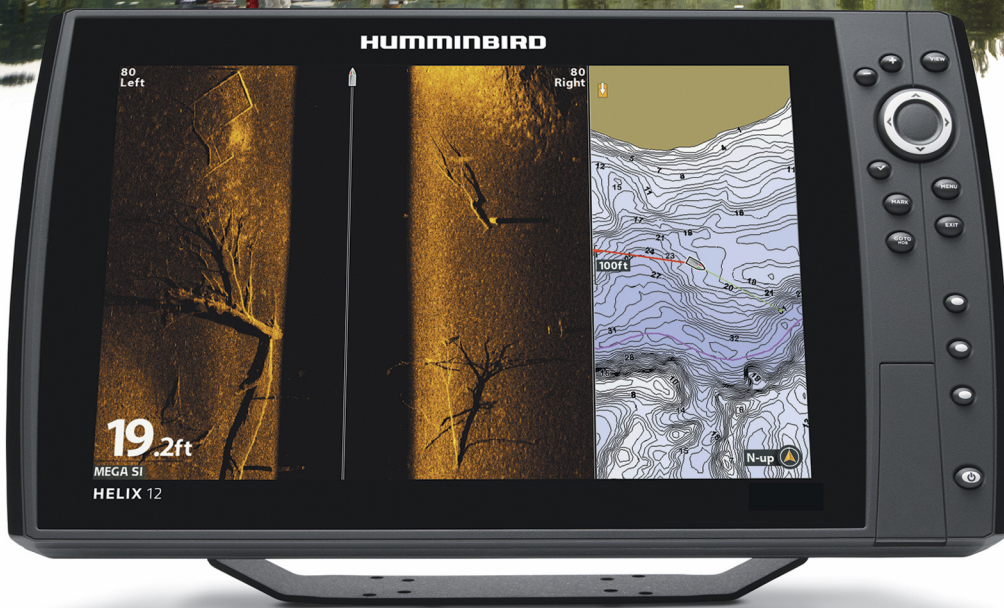



 **HUMMINBIRD®**

SIMPLY. CLEARLY. BETTER.

THANK YOU!

Thank you for choosing Humminbird®, the #1 name in marine electronics. Humminbird has built its reputation by designing and manufacturing top quality, thoroughly reliable marine equipment. Your Humminbird is designed for trouble-free use in even the harshest marine environment. We encourage you to read this operations manual carefully in order to get the full benefit from all the features and applications of your Humminbird product.

 **NOTE:** The illustrations in this manual may not look the same as your product, but your unit will function in the same way.

 **NOTE:** To purchase accessories or any additional equipment for your control head configuration.

 **NOTE:** The procedures and features described in this manual are subject to change without notice. This manual was written in English and may have been translated to another language. Humminbird is not responsible for incorrect translations or discrepancies between documents.

 **NOTE:** Product specifications and features are subject to change without notice.

TABLE OF CONTENTS

Warnings	2
Introduction	5
Overview	5
Transom Mount	6
Turbulence	6
Trailerling	7
Deadrise	7
Measuring the Transom Angle	8
Leveling Your Boat	8
Mounting Angle	9
High Speed Operation	10
Side Imaging	10
Mounting to a Jack Plate	11
Considering Different Boat Types	12
In-Hull Mount	13
Mounting Location	13
Thru-Hull Mount	14
Outside the Boat	14
Inside the Boat	14
Side Imaging	14
Installation Scenarios	15
Trolling Motor Mount	17
Contact Humminbird	18

INTRODUCTION

Proper transducer placement and mounting is one of the most critical aspects of sonar performance. The accuracy of the sonar display is affected by the location and type of transducer. Follow the tips in this resource guide to help you determine the best place to mount your transducer on your boat.



NOTE: Read the transducer installation guide completely to understand the mounting guidelines before starting the installation.



NOTE: Each boat hull represents a unique set of requirements that should be evaluated prior to installation. It is important to read the instructions completely and understand the mounting guidelines before beginning installation.



NOTE: For complete details about the installation and operation of your Humminbird control head, refer to the installation guide included with your control head and your control head operations manual.

Overview

This manual will guide you through the best practices for selecting an installation location for the following types of transducers:

- Transom Mount
- In-Hull Mount
- Thru-Hull Mount
- Trolling Motor Mount

TRANSOM MOUNT

The transom installation, which is the most widely used, places the transducer on the outside of the boat hull. This technique produces the least signal loss, and provides a way to adjust the transducer after installation. The mounting hardware included is designed to protect both the boat and the transducer should the boat strike debris in the water or when trailering.

Transom Mounted Transducer

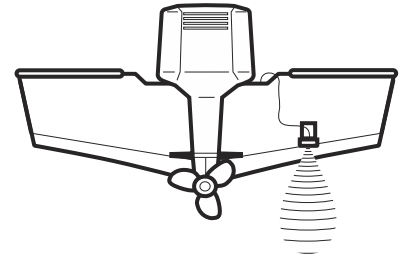

Turbulence

It is very important to locate the transducer in an area that is relatively free of turbulent water. As the boat moves through the water, turbulence is generated by the weight of the boat and the thrust of the propeller[s] – either clockwise or counterclockwise. Consider the following to find the best location with the least amount of turbulence:

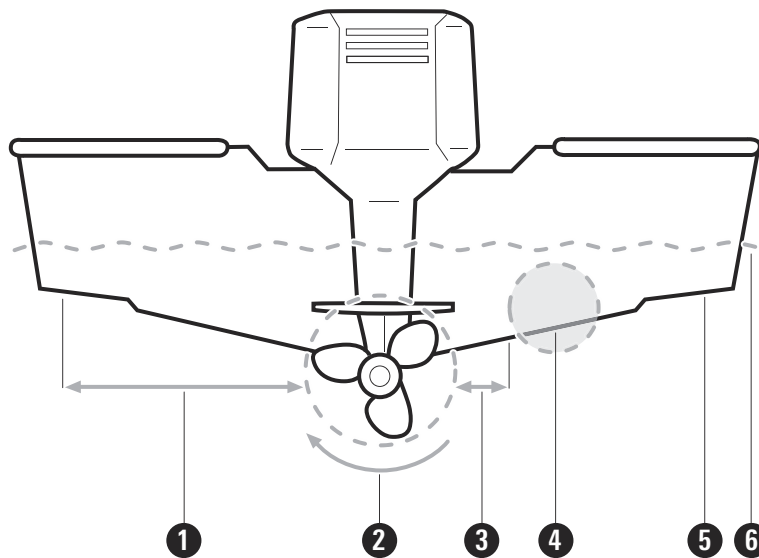

- 1 Avoid areas where there is turbulent water flow.** Turbulent water is normally confined to areas immediately aft of ribs, strakes, or rivets on the bottom of the boat, and in the immediate area of the propeller[s]. The best way to locate turbulence-free water is to view the transom while the boat is moving. This method is recommended if maximum high-speed operation (up to 65 mph) is a high priority. If this is not possible, select a location on the transom where the hull forward of this location is smooth, flat, and free of protrusions or ribs.
- 2 Observe your propeller's direction of rotation** [in forward, as you're facing the stern of the boat from behind]. Clockwise propellers create more turbulence on the port side. Counterclockwise propellers create more on the starboard side.
- 3 Ensure there is adequate distance from the propeller[s].** On outboard or inboard/outboard boats, it is best to locate the transducer at least 15" [38.1 cm] to the side of the propeller[s]. See the **Side Imaging** section for additional Side Imaging mounting requirements.
- 4 The ideal mounting location [right of the propeller[s]].** It is important to note that if you plan to trailer your boat, do not mount the transducer too close to trailer bunks or rollers to avoid moving or damaging the transducer during loading and unloading of the boat.
- 5 For boats with stepped hulls,** it may be possible to mount the transducer on the step. Do not mount the transducer on the transom behind a step to avoid popping the transducer out of the water at higher speeds. The transducer must remain in the water for the control head to maintain the sonar signal.
- 6 The transducer must be mounted so that it is parallel with the waterline, but fully submerged in the water during operation.**

Areas of Possible Turbulence

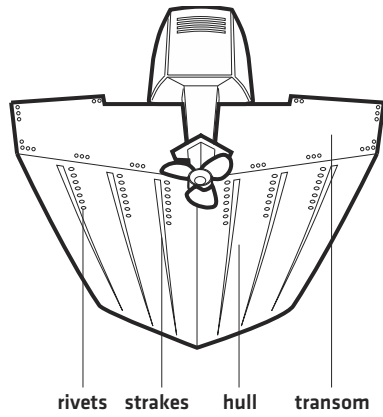

Stepped Hull

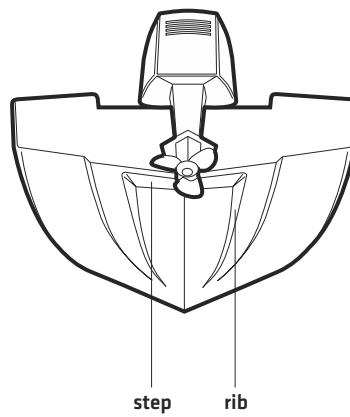

If the transom is behind the propeller[s], it may be impossible to find an area clear from turbulence, and a different mounting technique or transducer type should be considered.

Trailing

If you plan to trailer your boat, do not mount the transducer too close to trailer bunks or rollers to avoid moving or damaging the transducer during loading and unloading of the boat.

Deadrise

The hydrodynamic shape of your transducer allows it to point straight down without deadrise adjustment.

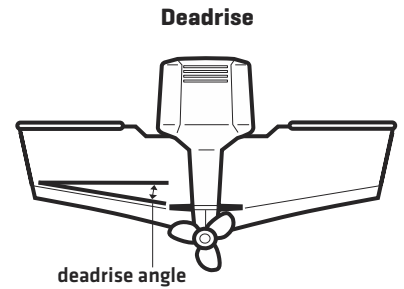

Measuring the Transom Angle

If you do not know your transom angle, measure it using a plumb line (weighted nylon string or monofilament line) exactly 12 inches long.

1. Hold the top of the plumb line against the top of the transom with your finger, and wait until the line hangs straight down.
2. Using a ruler, measure the distance from the bottom of the plumb line to the back of the transom. Refer to the illustration for more information.

NOTE: It is important to take your measurement in the location shown in the **Measuring the Transom Angle** illustration, from exactly 12 inches down from the top of the transom.

3. Once you have calculated your transom angle, use the chart below for the initial position to use to set the ratchets on your transducer assembly.

Measuring the Transom Angle

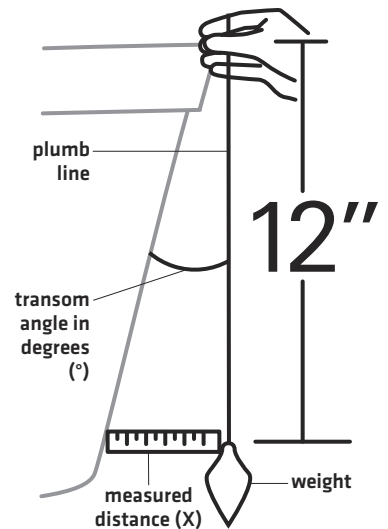

Bead Alignment Number	1	4	2	5	3	1	4	2	5	3	1																									
Transom Angle (°)	-2	-1	0	1	2	3	4	5	6	7	8	9	10	11	12	13	14	15	16	17	18	19	20	21	22	23	24	25	26	27	28	29	30			
Measured Distance (x)	0.0 cm	0"	1.1 cm	1/2"	2.5 cm	1"	4.3 cm	1 5/8"	5.9 cm	2 3/8"	7.6 cm	3"	9.3 cm	3 5/8"	11.1 cm	4 3/8"	12.9 cm	5"	14.9 cm	5 7/8"	16.9 cm	6 5/8"														

Leveling Your Boat

Make sure that the boat is level on the trailer, both from port to starboard and from bow to stern, by placing your level on the deck of the boat, first in one direction, then in the other. The transducer must be level with the bottom of the hull to ensure accurate depth readings.

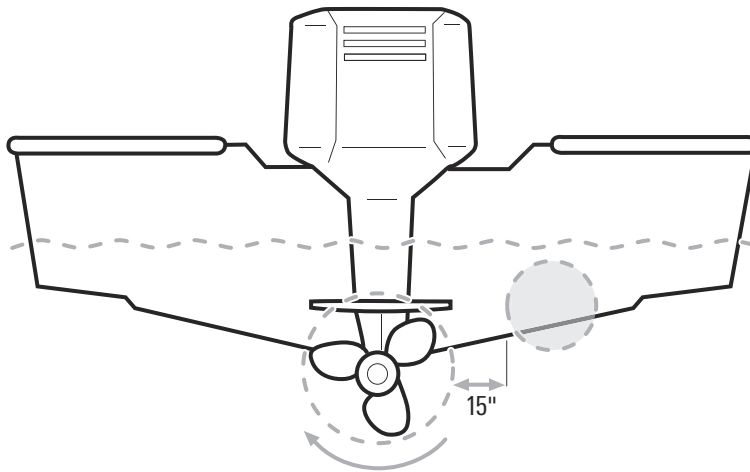

Find a turbulence-free location at least 15" from the propeller(s) and not in line with trailer bunks or rollers.

You can use the following tips to make sure your boat is level when out of the water.

1. Launch your boat in the water, and set to sonar scanning speed [2-4 mph].
2. Place a level on the gunnel of the boat.
3. Stack coins under the back of the level until it is leveled.
4. Remove the coins and set them aside for later.
5. Place the boat back on the trailer and on level ground.
6. Put the level back on the gunnel, in the same location you placed it on the water and place the same number of coins under one end.
7. Raise the trailer jack until the level is back to level position. Depending on your boat or trailer, you may need to use blocks under the trailer jack to get it level.

Mounting Angle

The transducer should be even with the bottom of the boat or slightly below the bottom.

Adjusting the Initial Transducer Angle

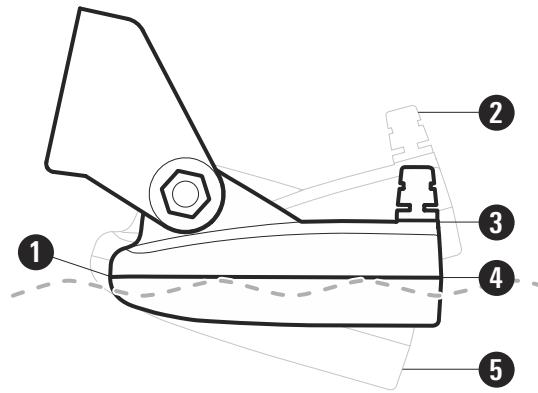

- ❶ **Leading edge** [the edge closest to the transom of the boat].
- ❷ **One click too high:** the transducer is tilted out of the water and cannot maintain a sonar signal. If the transducer is installed higher than the bottom of the boat, turbulence will roll off the edge of the boat bottom and cause interference.
- ❸ **Trailing edge** [the edge farthest away from the boat].
- ❹ **Correctly aligned:** the transducer side seam is parallel with the water line.
- ❺ **One click too low:** the deeper the transducer is in the water, the more likely that a rooster tail of spray and air bubbles will be generated at high speeds. You also risk the transducer being struck and damaged by objects in the water, so make sure that the transducer is as high as it can be and still be submerged in the water.

High Speed Operation

The location of the transducer becomes more critical as boat speed increases. Both front-to-rear and side-to-side transducer mounting angles are critical to high-speed performance. You may have to adjust the mounting angles to get top performance at high speeds. You want to keep the transducer in contact with the water while adding minimal drag. See the **Side Imaging** section for high speed options with your Side Imaging transducer.

Side Imaging

Side Imaging sonar uses two very precise sonar beams that are aimed at right angles to the path of the boat. The side beam coverage is very thin from front to back, yet very wide from top to bottom. The beams provide thin slices of the bottom for high resolution imaging.

The Side Imaging transducer has some special requirements because of its side viewing capabilities:

- The Side Imaging transducer must NOT have anything obstructing the 'view' of the side looking beams. For example, nothing can be in the line of sight of these beams (not a hull, motor, or other transducer, etc.).

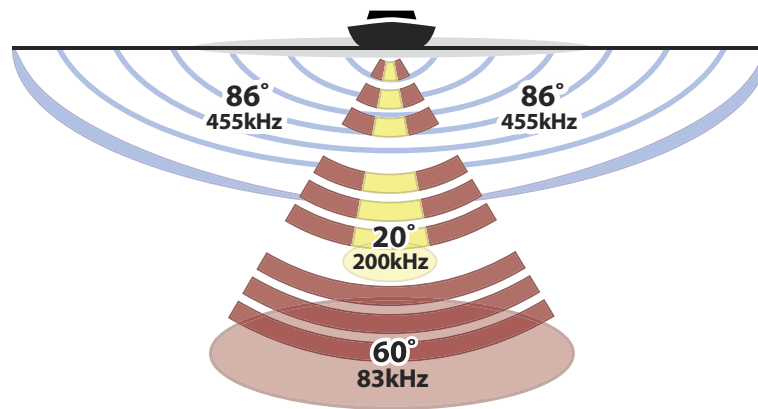

NOTE: You may need to tilt the motor up and out of the way when using the side looking beams.

- In order for the side beams to be displayed accurately, the transducer must be mounted so that it is looking straight down in the water when the boat is in the water.

Transducer Mount Position

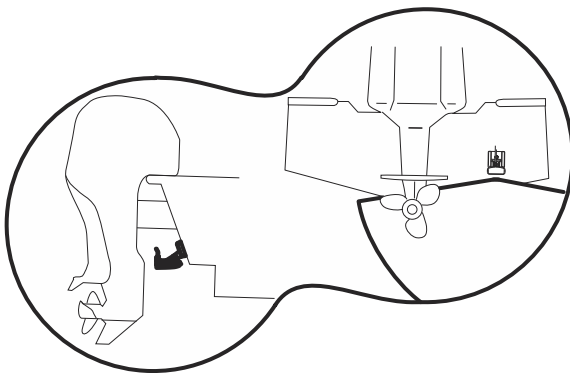

Unobstructed View: The jack plate gives the transducer safe distance from the motor and turbulence. The Side Imaging has a clear view side-to-side.

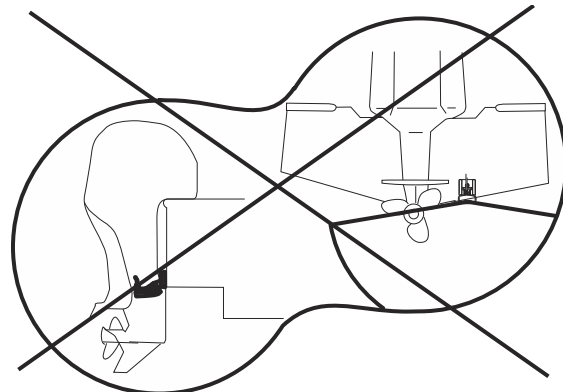

Obstructed View: The transducer is too close to motor turbulence, and the Side Imaging view is blocked by the motor. The view cannot extend from side-to-side.

Straight/Parallel: In order for the side beams to be displayed accurately, the transducer must be mounted parallel with the waterline, so that it is looking straight down in the water when the boat is in the water.

High Speed Operation: Side Imaging sonar is best performed at boat speeds from 2 to 6 mph, and it is not recommended for high-speed operation as gaps between strips of information can appear. However, the transducer can support traditional 2D sonar and Down Imaging sonar at higher speeds.

You can install an additional transducer with a Splitter Y-cable so that one transducer is mounted to provide Side Imaging returns and the other transducer is mounted to provide 2D sonar returns at high speeds.

 **NOTE:** Y-cables vary based on the control head model.

Mounting to a Jack Plate

The transducer transom bracket can be mounted directly to a jack plate by drilling through the jack plate or by installing a bracket to the jack plate.

Before installing the transducer on the jack plate, make sure there is enough clearance between the jack plate, engine, transom, and the transducer. Lack of clearance could damage the transducer when the engine is all the way down.

Mounting to a Jack Plate

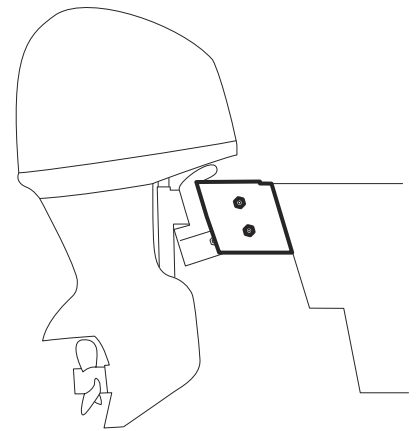

Considering Different Boat Types

Your boat's hull type will determine the transducer mounting location. Here are some tips for various boat types.

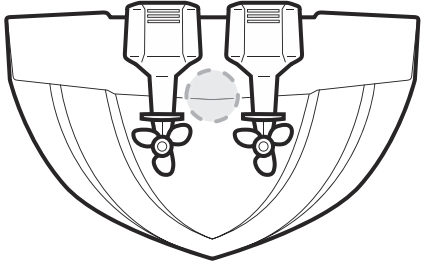
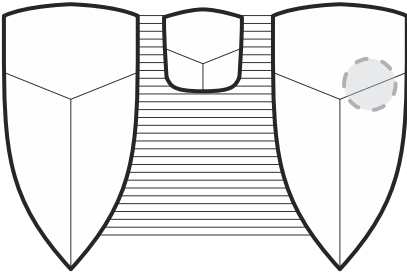
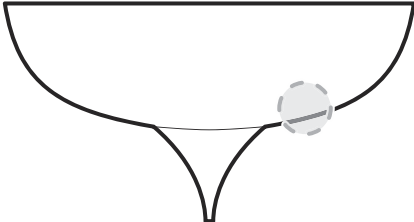
	<p>On twin-drive boats, the transducer should be mounted between drives.</p>
	<p>On pontoon boats, place the transducer on the bottom of the bracket on the back of a pontoon tube. The starboard side usually requires less cord to route to the control head. Also, place the transducer away from electrical interference and a livewell pump. Make sure the transducer is parallel to the water line and not the pontoon.</p> <p>Side Imaging may require a separate Side Imaging transducer mounted on each pontoon, connected with a L/R Y-cable.</p>
	<p>On sailboats, mount the transducer on the starboard side of the boat, at least 6" outside the keel.</p>

IN-HULL MOUNT

In-hull transducers (also known as shoot-through transducers) are installed inside of fiberglass boats. They are epoxied to the boat hull. Since fiberglass has similar sonar characteristics as water, the sonar signal can pass through the boat hull with minimal loss. The hull of the boat must be single layer construction (not double-hulled) and should not contain any foam. Any air trapped in the lamination of fiberglass would prevent the sonar signal from passing through the fiberglass. This method will not work for any Side Imaging transducers.

Some advantages of in-hull mounts include the following:

- no holes in the hull
- no exposure to marine growth
- good high speed performance
- no protruding obstructions that might increase drag
- no worry about damage to the transducer from debris or trailering

However, the disadvantage is that in-hull transducers may experience reduced depth range, depending on the thickness of the hull.

Do not mount Side Imaging or Down Imaging transducers in-hull.

Mounting Location

Use the following tips to find the best place to locate your in-hull transducer.

- Observe the outside of the boat hull to find the areas that are mostly free from turbulent water. Avoid ribs, strakes, and other protrusions, as these create turbulence.
- Make sure that the transducer is located as close to the centerline of the hull and as far aft as possible, so that it will remain in contact with the water even at high speeds.
- Install the transducer away from interference caused by power and radiation sources, such as the propeller and other cables.
- Locate the transducer on a flat surface of solid fiberglass. Areas of thicker fiberglass can reduce the depth range. Fiberglass hulls may be reinforced in places for added strength. Do not place the transducer near any wood, metal, or foam reinforcements.
- Ensure the transducer beam will not be blocked by the keel or propeller shaft.

Preferred Mounting Area

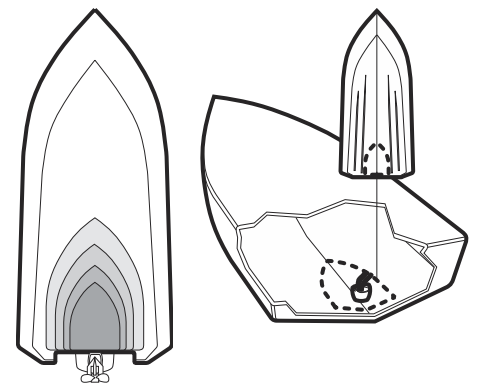

Inside the Hull Installation

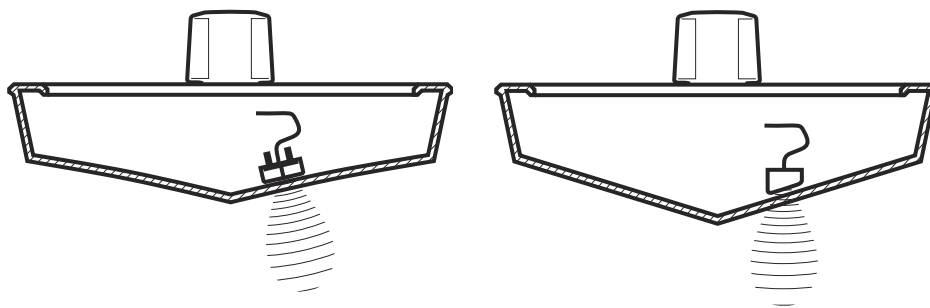

Once you have selected a mounting location, perform an on-the-water test by placing the transducer in a bag of water or by filling the hull with water and hold down the transducer with a sand bag before permanently installing the transducer with the two-part epoxy.

THRU-HULL MOUNT

Thru-hull transducers are mounted through a hole drilled in the bottom of the boat.

Outside the Boat

⚠ WARNING! Do NOT install the transducer in line with the engine intake.

- The best location for the transducer will be aft midship, as close to centerline of the boat as possible. The transducer should be mounted forward of the propellers on inboard boats, and separated adequately from other transducers, strakes, rivet lines, or other protrusions that may create turbulence. Make sure there is nothing in front, behind, or to the side of the transducer that is closer than 12".
- Do not mount the transducer where it could be damaged from trailering, launching, or storage.
- The transducer must be continuously immersed in water.
- Choose a location with a minimal deadrise angle.

Inside the Boat

- Ensure there is enough room to access the mounting location for installation and cable routing.
- If you need a leveling block, make sure that the inside surface of the hull is smooth enough to seat the leveling block securely.

Side Imaging

A side imaging transducer must not have anything obstructing the "view" of the side looking beams. For example, nothing can be in the sight line of these beams [not a hull, motor, or other transducer, etc.].

In order for the side beams to be displayed accurately, the transducer must be mounted so that it is looking straight down in the water when the boat is in the water.

Side Imaging - Install the transducer so the beams are not obstructed.

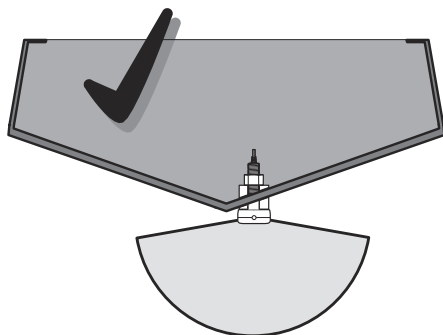

RECOMMENDED:
In the illustration, the transducer is close enough to the centerline so that the hull will not interfere with the Side Imaging beams.

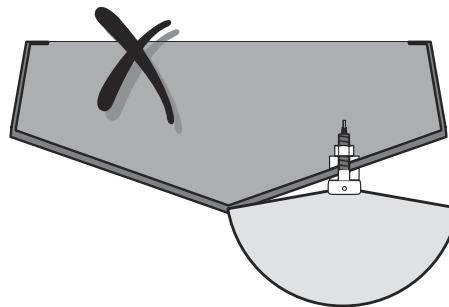

NOT RECOMMENDED:
In the illustration, the transducer is too far from the centerline, and the hull is blocking the Side Imaging beams.

Installation Scenarios

- **Flat Hull, One Transducer:** Locate a flat area on the bottom of the hull, forward of where the propeller shaft comes out of the hull. Make sure there is nothing lower than this location to the right or left.
- **V-shaped Hull, Two Transducers:** Install two thru-hull transducers, one on each side of the V. Connect the transducers with a Y-Cable.
- **Two Back Engines, Two Transducers:** Install two thru-hull transducers outboard from the dual engines. Connect the transducers with an Y-Cable.



NOTE: Installations with two transducers require a Y-Cable (or Splitter Cable), which vary based on the control head model.

Flat Hull, One Transducer

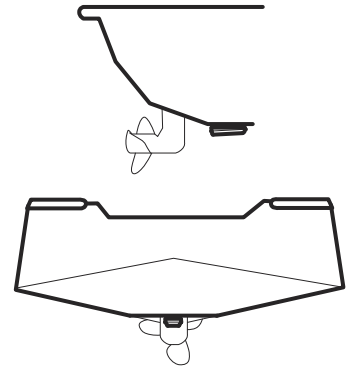

V-shaped Hull, Two Transducers OR Two Back In-Board Engines, Two Transducers

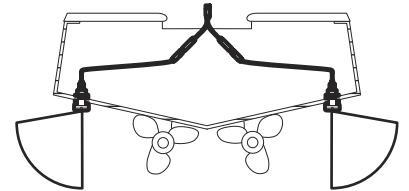

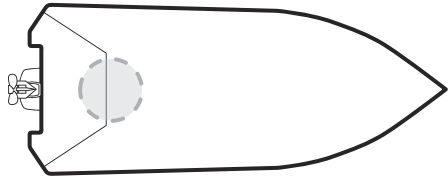
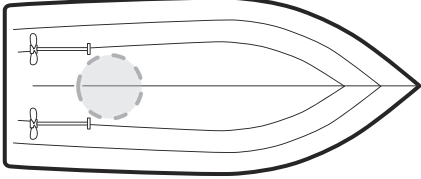
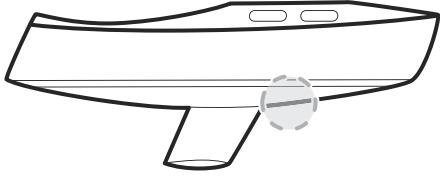
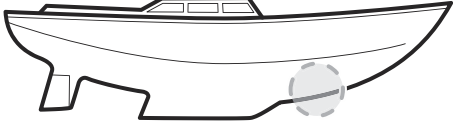
	<p>For outboard and inboard/outboard boats, mount the transducer just forward and to the side of the engine[s].</p>
	<p>For inboard boats, mount the transducer ahead of the propeller[s] and shaft[s].</p>
	<p>For fin keel sailboats, mount the transducer to the side of the centerline and forward of the fin keel 1' to 2'.</p>
	<p>For full keel sailboats, mount the transducer midship and away from the keel at the point of minimum deadrise angle.</p>

TROLLING MOTOR MOUNT

Confirm the transducer is oriented in the trolling motor's direction of travel.

Position the transducer on the underside of the motor housing with the front of the transducer facing away from the propeller.

Directional Bias

Round, circular-bottomed transducers have no directional bias, and therefore orientation of these types of transducers is not as important. Rounded rectangular transducers, however, do have a directional bias, and must be installed as shown in the illustration.

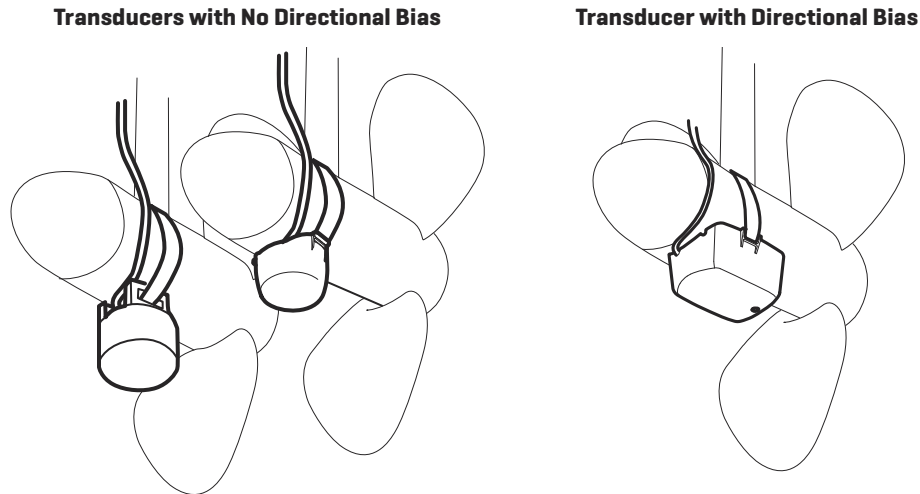

Routing the Cables

The transducer cable should be routed through the coil cable. Leave enough slack for proper stow and deploy. Make sure that the transducer cable does not get pulled, cut, or crushed.



NOTE: Do not use a transom mount Down Imaging transducer with an adapter kit on a trolling motor. The Down Imaging transducer made for a trolling motor has extra shielding in the housing and cables. If your included transducer will not work for your application, you may exchange it, NEW and UNASSEMBLED, with mounting hardware included, for a transducer appropriate for your application.