

Thank You

Thank you for choosing Humminbird®, America's #1 name in fishfinders. Humminbird® has built its reputation by designing and manufacturing top-quality, thoroughly reliable marine equipment. Genuine Humminbird® accessories offer the opportunity to upgrade and expand the capabilities of your Humminbird® product.

NOTE: Your transducer may not look exactly like the transducer shown in the illustrations, but it will mount in exactly the same way.

Your Humminbird® is designed for trouble-free use in even the harshest marine environment. In the unlikely event that your Humminbird® does require repairs, we offer an exclusive Service Policy - free of charge during the first year after purchase, and available at a reasonable rate after the one-year period. For complete details, see the Warranty section included in this manual.

Installation Overview

Following are instructions for the installation of this accessory. Before you start the installation, we encourage you to read these instructions carefully in order to get the full benefit from your Humminbird® accessory.

In addition to the hardware supplied with your transducer, you will need a powered hand drill and various drill bits, various hand tools, including a ruler or measuring tape, level, pen or pencil, safety glasses and dust mask, and marine-grade silicone sealant.

Installation

There are a number of ways to install a transducer on your boat. The transom mount installation provides the least loss of signal since the transducer is mounted outside the boat hull. This installation also allows adjustment of both running angle and depth after the transducer is mounted, which enables you to tune the installation for best results. Also, the mounting hardware is designed to pivot the transducer body out of the way should the boat strike debris in the water, or when trailering.

1. Locating the Transducer Mounting Position

Turbulence: You must first determine the best location on the transom to install the transducer. It is very important to locate the transducer in an area which is relatively free of turbulent water. Consider the following to find the best location with the least amount of turbulence:

- As the boat moves through the water, turbulence is generated by the weight of the boat and the thrust of the propeller(s) - either clockwise or counter-clockwise. This turbulent water is normally confined to areas immediately aft of ribs, strakes or rows of rivets on the bottom of the boat, and in the immediate area of the propeller(s). Clockwise propellers create more turbulence on the port side. On outboard or inboard/outboard boats, it is best to locate the transducer at least 15" to the side of the propeller(s).
- The best way to locate turbulence-free water is to view the transom while the boat is moving. This method is recommended if maximum high-speed operation is a high priority. If this is not possible, select a location on the transom where the hull forward of this location is smooth, flat and free of protrusions or ribs.

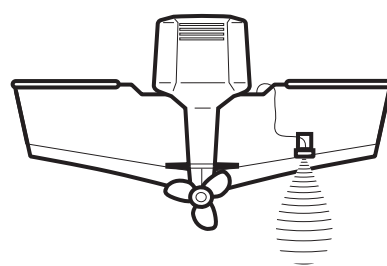
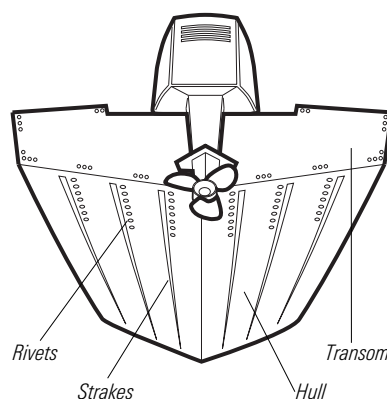
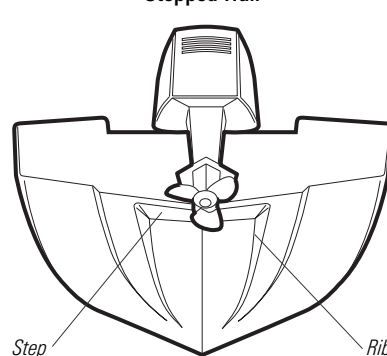
Transom Mounted Transducer

Areas of Possible Turbulence

Stepped Hull

- On boats with stepped hulls, it may be possible to mount the transducer on the step. Do not mount the transducer on the transom behind a step to avoid popping the transducer out of the water at higher speeds; the transducer must remain in the water for the control head to maintain the sonar signal.

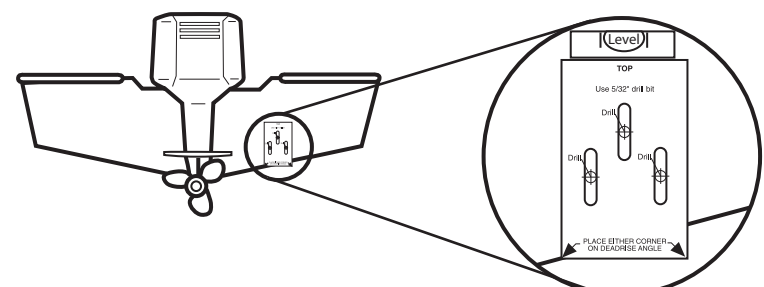
- If the transom is behind the propeller(s), it may be impossible to find an area clear from turbulence, and a different mounting technique or transducer type should be considered.

- If you plan to trailer your boat, do not mount the transducer too close to trailer bunks or rollers to avoid moving or damaging the transducer during loading and unloading of the boat.



Find a turbulence-free location at least 15" from the propeller(s) and not in line with trailer bunks or rollers.

NOTE: The hydrodynamic shape of your transducer allows it to point straight down without deadrise adjustment.

NOTE: If you cannot find a transom mount location that will work for your high-speed application, a different mounting technique or transducer type should be considered.

Side Imaging: The Side Imaging transducer has some special requirements because of its side viewing capabilities:

- The Side Imaging transducer must NOT have anything obstructing the 'view' of the side looking beams; for example, nothing can be in the line of sight of these beams (not a hull, motor, or other transducer, etc.)

NOTE: You may need to tilt the motor up and out of the way when using the side looking beams.

- In order for the side beams to be displayed accurately, the transducer must be mounted so that it is looking straight down in the water when the boat is in the water.

2. Mounting the Bracket

In this procedure you will mount the bracket, using the mounting template provided as a guide. This template allows you to mark where the mounting holes should be drilled.

- Cut out the transducer mounting template from this sheet. Match the mounting bracket screw slots to the template screw slots.
- Hold the template on the transom of the boat in the location you have selected. Align the template vertically, matching the lower edge of the transom with the bottom corner of the template.

NOTE: If your propeller moves clockwise as the boat moves forward (as you're facing the stern of the boat from behind), mount the transducer on the starboard side, and use the bottom left corner of the template. If your propeller moves counter-clockwise as the boat moves forward (as you're facing the stern of the boat from behind), mount the transducer on the port side, and use the bottom bottom right corner of the template.

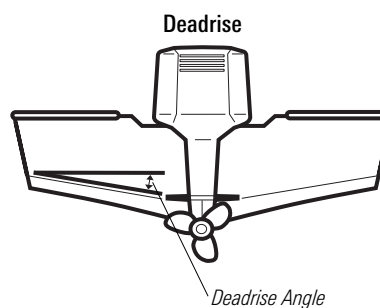
Transducer Mount Position

Unobstructed View: The jack plate gives the transducer safe distance from the motor and turbulence. The side imaging has a clear view side-to-side.

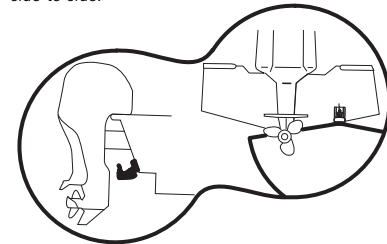

Obstructed View: The transducer is too close to motor turbulence, and the side imaging view is blocked by the motor. The view cannot extend from side-to-side.

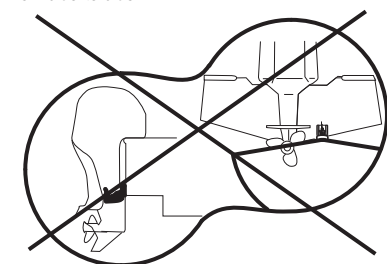
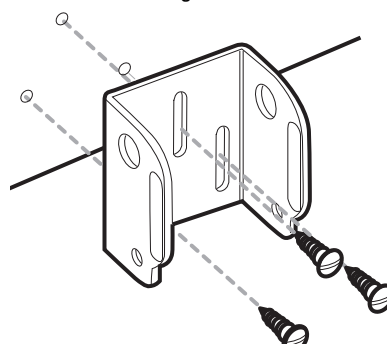
Attaching the Bracket

- Continue to hold the template on the transom of the boat, and use a pencil or punch to mark where to drill the three mounting holes shown on the template.
- Using a 5/32" bit, drill the three holes only to a depth of approximately 1".

NOTE: On fiberglass hulls, it is best to use progressively larger drill bits to reduce the chance of chipping or flaking the outer coating.

- Use a marine-grade silicone sealant to fill the drilled holes, especially if the holes penetrated the transom wall.

- Align the metal mounting bracket with the mounting holes. The center slot of your mounting bracket should be above the two outer slots. This bracket and all other hardware supplied is top quality stainless steel for maximum strength and corrosion protection. Insert the three 1" flat head wood screws into the drilled holes, but do not completely tighten.

3. Assembling the Transducer

In this procedure you will attach the pivot to the transducer using the hardware provided.

- Attach the pivot to the transducer body as shown in the illustration using the square nuts, toothed washers, and two 1/4-20 x 5/8" machine screws. The square nuts will be prevented from rotating by the pocket in the back of the pivot. The toothed washers must fit on the inside of the transducer ears, between the pivot and the ears.

NOTE: An Allen wrench is provided which fits all of the 1/4-20 screws, but do not fully tighten the screws at this time.

4. Attaching the Transducer to the Bracket

- Slide the assembled transducer into the metal bracket from the bottom, aligning the large hole at the top of the bracket with the hole in the pivot.
- Insert the headed pin through the pivot holes in the bracket and pivot. The headed pin can be inserted from either side of the bracket.

- Place the nylon washer over the opposite end of the headed pin. Place the stainless washer over the 1/4-20 x 5/8" screw threads, then insert into the opposite end of the headed pin and finger tighten only. The screw has a thread locking compound on the threads to prevent loosening, and should NOT be fully tightened until all adjustments are made.

5. Running Position Adjustment

The running position of the transducer is now completely adjustable. Subsequent adjustment may be necessary to tweak the installation after high speed testing. The mounting bracket allows height and tilt adjustment; the pivot screws allow angle adjustment.

NOTE: Side imaging is best performed at boat speeds from 2 to 6 mph. If the boat is stationary, the same information is displayed over and over. If the boat is moving too quickly, there will be gaps between the strips of information. The best boat speed to use will depend on the side range selected. Slower speeds are good for longer ranges, while faster speeds can be used at shorter ranges.

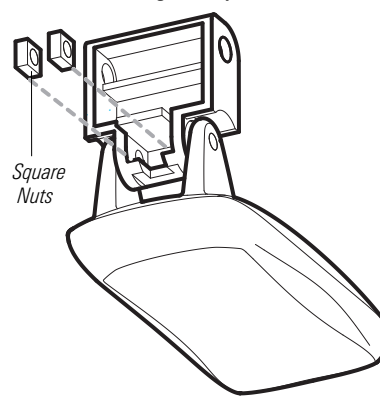
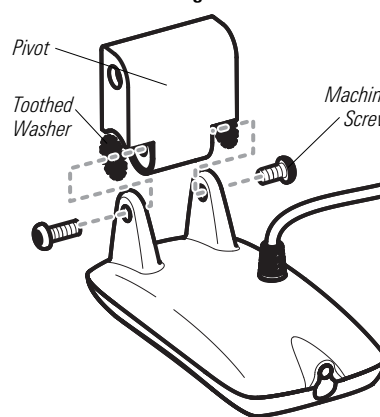
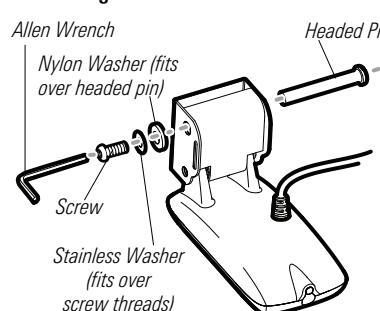
Inserting the Square Nuts

Attaching the Pivot

Attaching the Transducer to the Bracket

- Adjust the angle of the transducer body first, so it is parallel with the hull of the boat, and fully tighten the two pivot screws using the supplied Allen wrench. Access to the pivot screws is provided by the lower holes in the side of the mounting bracket.

- Next, adjust the height of the assembly so the face of the transducer is 1/8" to 1/4" beneath the bottom of the transom, and fully tighten the three mounting screws. In order to gain access to the mounting screws, the transducer assembly must be pivoted up into the bracket as shown.

CAUTION! Be careful not to alter the running angle, as some force is necessary to pivot the assembly.

- If access to the top mounting hole is not possible due to the selected height of the transducer, fully tighten the two lower screws. Remove the headed pivot pin and the transducer assembly, tighten the top screw, and then reassemble.

- Confirm that the pivot angle has not changed and that all mounting screws are fully tightened.

6. Routing the Cable

The transducer cable has a low profile connector which must be routed to the point where the control head is mounted. There are several ways to route the transducer cable to the area where the control head is installed. The most common procedure routes the cable through the transom into the boat.

NOTE: Your boat may have a pre-existing wiring channel or conduit that you can use for the transducer cable.

- Unplug the other end of the transducer cable from the control head. Make sure that the cable is long enough to accommodate the planned route by running the cable over the transom.

CAUTION! Do not cut or shorten the transducer cable, and try not to damage the cable insulation. Route the cable as far as possible from any VHF radio antenna cables or tachometer cables to reduce the possibility of interference. If the cable is too short, extension cables are available to extend the transducer cable up to a total of 50'.

NOTE: The transducer can pivot up to 90 degrees in the bracket. Allow enough slack in the cable for this movement. It is best to route the cable to the side of the transducer so the transducer will not damage the cable during movement.

- If you are routing the cable over the transom of the boat, secure the cable by attaching the cable clamp to the transom, drilling 9/64" diameter holes for #8 x 5/8" wood screw(s), go directly to procedure 7, **Connecting the Cable**.

or...

- If you will be routing the cable through a hole in the transom, drill a 5/8" diameter hole above the waterline. Route the cable through this hole, then fill the hole with marine-grade silicone sealant and proceed to the next step immediately.

- Place the escutcheon plate over the cable hole and use it as a guide to mark the two escutcheon plate mounting holes. Remove the plate, drill two 9/64" diameter x 5/8" deep holes, and then fill both holes with marine-grade silicone sealant. Place the escutcheon plate over the cable hole and attach with two #8 x 5/8" wood screws. **Hand tighten only!**

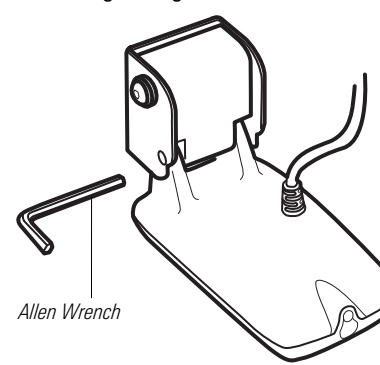
Tightening the Pivot Screw

Allen Wrench

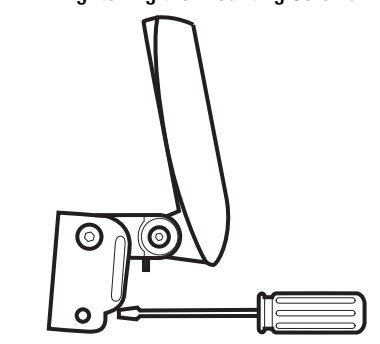
Tightening the Mounting Screws

- Route and secure the cable by attaching the cable clamp to the transom; drill one 9/64" diameter x 5/8" deep hole, then fill the hole with marine-grade silicone sealant, then attach the cable clamp using a #8 x 5/8" screw. **Hand tighten only!**

NOTE: If there is excess cable that needs to be gathered at one location, dress the cable routed from both directions so that a single loop is left extending from the storage location. Doubling the cable up from this point, form the cable into a coil. Storing excess cable using this method can reduce electronic interference.

7. Connecting the Cable

Insert the transducer cable into the appropriate terminal slot. The cable connectors are labeled, and there are corresponding labels on the cable holder on the rear of the fishfinder. The slots are keyed to prevent reversed installation, so be careful not to force the connector into the holder.

8. Test and Finish the Installation

Once you have installed both the control head and the transom transducer, and have routed all the cables, you must perform a final test before locking the transducer in place. Testing should be performed with the boat in the water, although you can initially confirm basic operation with the boat out of the water.

- Press POWER once to turn the control head on. If the unit does not power-up, make sure that the connector holder is fully seated in the receptacle and that power is available.
- If all connections are correct and power is available, the Humminbird® control head will enter Normal operation.
- If the bottom is visible on-screen with a digital depth readout, the unit is working properly. Make sure that the boat is in water greater than 2' but less than the depth capability of the unit, and that the transducer is fully submerged, since the sonar signal cannot pass through air.

NOTE: The transducer must be submerged in water for reliable transducer detection.

- If the unit is working properly, gradually increase the boat speed to test high-speed performance. If the unit functions well at low speeds, but begins to skip or miss the bottom at higher speeds, the transducer requires adjustment.
- If you have the correct angle set on the transducer, yet lose a bottom reading at high speed, adjust the transducer to a lower depth in the water. If you reach the top of the screw slots and continue to lack high speed performance, increase the angle of the transducer by lowering the back of the transducer in increments of 1/8".

NOTE: It is often necessary to make several incremental transducer adjustments before optimum high speed performance is achieved. Due to the wide variety of boat hulls, however, it is not always possible to obtain high speed depth readings.

NOTE: The deeper the transducer is in the water, the more likely that a rooster tail of spray will be generated at high speeds, so make sure that the transducer is as high as it can be and still be submerged in the water.

- Once you have reached a consistently good sonar signal at the desired speeds, fully tighten your assembly to lock it into place.

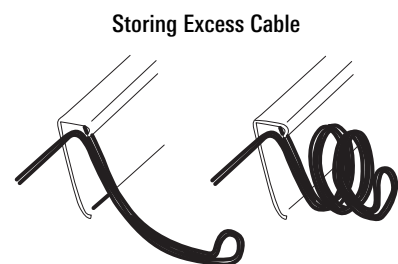
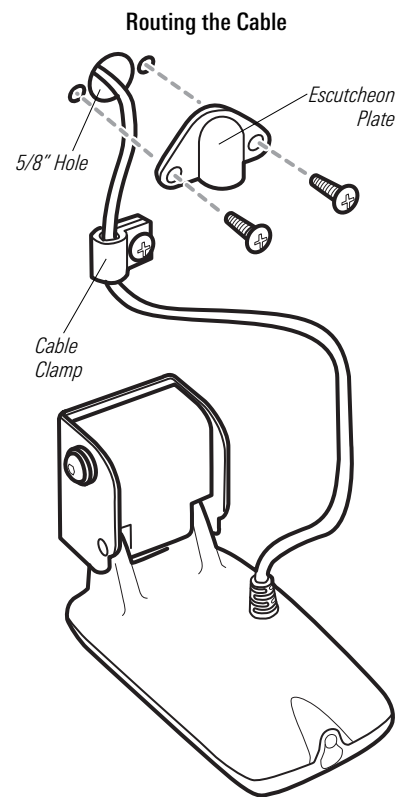

Maintenance

If your boat remains in the water for long periods of time, algae and other marine growth can reduce the effectiveness of the transducer. Periodically clean the face of the transducer with hot water.

If your boat remains out of the water for a long period of time, it may take some time to wet the transducer after it is returned to the water. Small air bubbles can cling to the surface of the transducer and interfere with proper operation. These bubbles will dissipate with time, or you may wipe the face of the transducer with your fingers after the transducer is in the water.

1-Year Limited Warranty

We warrant the original retail purchaser that products made by Humminbird® have been manufactured free from defects in materials and workmanship. This warranty is effective for one year from the date of original retail purchase. Humminbird® products found to be defective and covered by this warranty will be replaced or repaired free of charge at Humminbird® option and returned to the customer freight prepaid. Humminbird® sole responsibility under this warranty is limited to the repair or replacement of a product that has been deemed defective by Humminbird®. Humminbird® is not responsible for charges connected with the removal of such product or reinstallation of replaced or repaired parts.

This warranty does not apply to a product that has been:

- Improperly installed;
- Used in an installation other than that recommended in the product installation and operation instructions;
- Damaged or has failed because of an accident or abnormal operation;
- Repaired or modified by entities other than Humminbird®.

Please retain your original receipt as a proof of the purchase date. This will be required for in-warranty service.

THIS WARRANTY IS EXPRESSLY IN LIEU OF ANY OTHER WARRANTIES, OBLIGATIONS OR LIABILITIES ON THE PART OF HUMMINBIRD® AND WILL BE THE CUSTOMER'S EXCLUSIVE REMEDY, EXCEPT FOR ANY APPLICABLE IMPLIED WARRANTIES UNDER STATE LAW WHICH ARE HEREBY LIMITED IN DURATION TO ONE YEAR FROM THE DATE OF ORIGINAL PURCHASE. IN NO EVENT WILL HUMMINBIRD® BE LIABLE FOR ANY INCIDENTAL OR CONSEQUENTIAL DAMAGES FOR BREACH OF ANY EXPRESS OR IMPLIED WARRANTY RELATING TO THE PRODUCTS.

Some states do not allow limitations on an implied warranty, or the exclusion of incidental or consequential damages, so the above exclusions may not apply to you. You may also have other rights, which vary from state to state.