

Ice Fishing Transducer

531603-2_D

Thank You

Thank you for choosing Humminbird®, the #1 name in marine electronics. Humminbird has built its reputation by designing and manufacturing top-quality, thoroughly reliable marine equipment. Genuine Humminbird accessories offer the opportunity to upgrade and expand the capabilities of your Humminbird product.

NOTE: Your transducer may not look exactly like the transducer shown in the illustrations, but it will mount in exactly the same way.

Your Humminbird is designed for trouble-free use in even the harshest marine environment. In the unlikely event that your Humminbird does require repairs, we offer an exclusive Service Policy - free of charge during the first year after purchase, and available at a reasonable rate after the one-year period. For complete details, see the Warranty section included in this manual.

Installation Overview

Following are instructions for the installation of this accessory. Before you start installation, we encourage you to read these instructions carefully in order to get the full benefit from your Humminbird accessory.

Installation

Perform the procedures in the following sections to install the transducer to your portable case.

1. Testing the Transducer Prior to Installation

Prior to installation, test the transducer to make sure that no damage occurred during shipping.

WARNING! Before walking onto the ice, make sure that conditions are safe.

1. Connect the transducer to the control head.
2. Lower the transducer into the ice hole. If the transducer is working properly, you will see the bottom on the control head display.

2. Assembling the Transducer and Float

These instructions cover multiple transducer installations. Please read them carefully and refer to the correct illustrations for your installation type.

1. Thread the support cable through the support clip and then clip onto the transducer.
2. Attach your transducer float to the support cable by sliding the support cable through the slit in the float.

NOTE: Attaching the float is optional. You can also use the storage posts to hold the support cable in position.

Threading the Cable through Support clip



Attaching the Float to the Support Cable

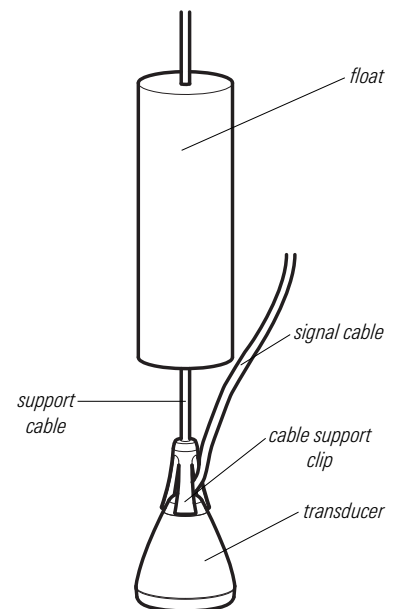

Ice Fishing Transducer

- Position the float so that the transducer will be submerged in the water, just below the ice.

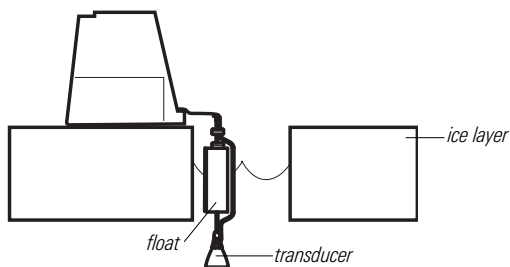

NOTE: The transducer must be submerged in water for reliable transducer detection. The bottom of the transducer should be even with the bottom of the ice or hang slightly below the bottom of the ice.

- Once you know where you want to position your float, place one of the cable clamps onto the support cable, above the float. Use the inside, smaller cable hole for the support cable so that the float will not move, and so that the transducer will maintain its position under the ice. Make sure that the support cable is taut, so that the transducer hangs straight down (see illustration).
- If you would like to keep the support and signal cables together above the float stop, attach a cable management clamp (included) to the support cable (using the inner, smaller hole) and the signal cable (using the outer, larger hole). Make sure that the signal cable has some slack so that it is not bearing the weight of the transducer.

3. Connecting the Transducer Cable

This section covers how to connect your transducer cable to your control head. Refer to the correct illustrations and instructions for your installation type.

- If you have an ICE Flasher Series™ control head**, insert the transducer cable into the appropriate terminal slot on the rear of the control head. The slots are keyed to prevent reversed installation, so be careful not to force the connector into the holder. If the cable connector feels tight, lightly coat the outside of the connector with silicone grease. Then, route the transducer signal cable beneath the control head and secure to the cable clips on the base.

NOTE: If you have an ICE 55 Flasher, remove the control head and base from the portable bag to connect the transducer cable, then reinstall it in the portable bag.

Connecting to the ICE Flasher

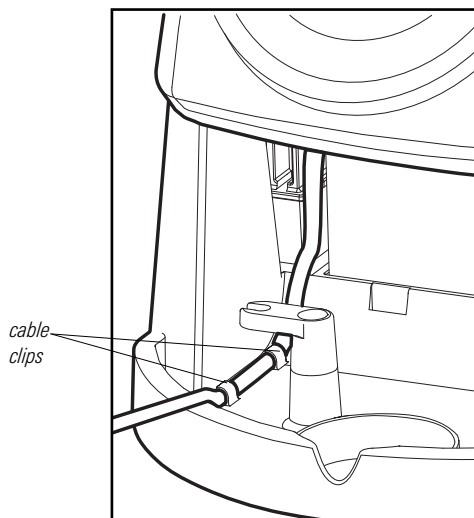
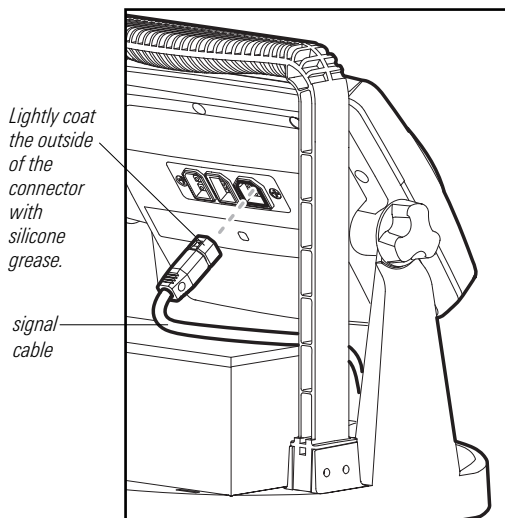

Cable Clamp

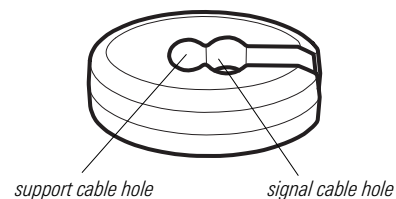

Attaching the Cable Clamps

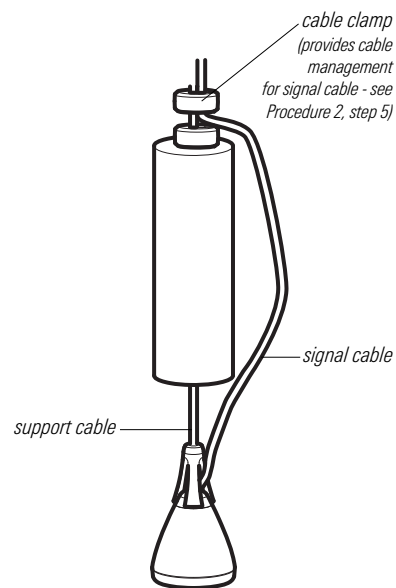
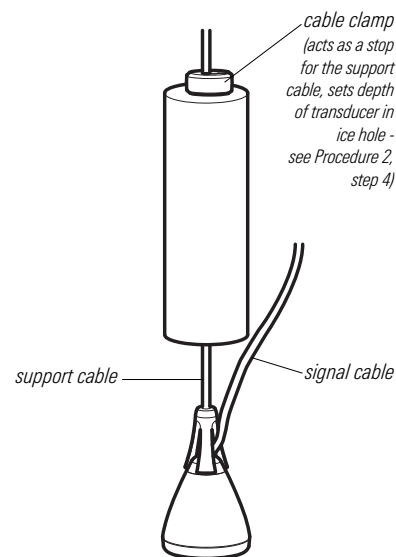

Ice Fishing Transducer

OR...

- 1b. **If you have a Humminbird portable bag**, plug the transducer signal cable into the jumper port in the portable bag to the left of the control head as you face the front of the portable bag.

CAUTION! Do NOT mount the cables where the connectors could be submerged in water or flooded. If cables are installed in a splash-prone area, it may be helpful to apply dielectric grease to the inside of the connectors to prevent corrosion. Dielectric grease can be purchased separately from a general hardware or automotive store.

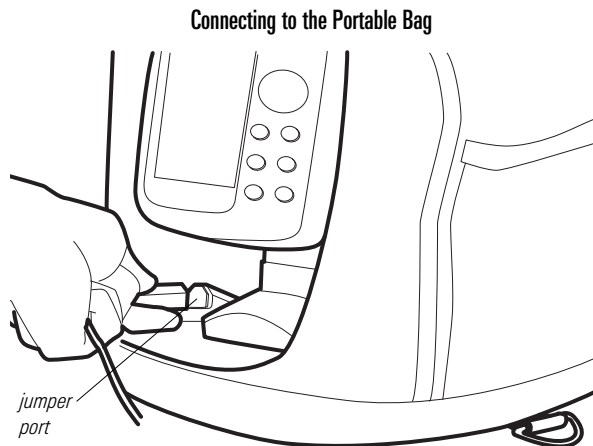

4. Set up Ice Fishing on the Fishfinder

If you connect the transducer to a Humminbird fishfinder, use the following instructions to configure the control head for ice fishing.

NOTE: If you connect the transducer to a Humminbird ICE Flasher, no further action required. See your ICE Flasher Series manual for operations information.

1. Press and hold the POWER/LIGHT key to power on the control head.
2. Press the MENU key. Use the 4-WAY Cursor Control key to select Normal.
3. **Main Menu:** Press the MENU key twice.
4. Use the 4-WAY Cursor Control key to select the Sonar tab > Transducer Select or Connected Transducer.

NOTE: If your fishfinder does not include the Transducer Select or Connected Transducer menu option, skip this step and proceed to step 6.

5. Press the RIGHT or LEFT Cursor keys to select Dual Beam.
6. Select Ice Fishing Mode from the Sonar tab.
7. Press the RIGHT or LEFT Cursor keys to select On or Off. (Default = Off)

When Ice Fishing Mode is off, the Circular Flasher View displays Real Time Sonar (RTS™) data in a traditional flasher format.

When Ice Fishing Mode is on, the Circular Flasher View displays the sonar data in traditional flasher format with additional features including Zoom and Depth Cursor. See your control head operations manual for details.

Ice Fishing Transducer

531603-2_D

8. **DI Units only:** If the control head is a Down Imaging® model (for example, the 386ci DI), select Digital Depth Source from the Sonar tab. Press the RIGHT or LEFT Cursor keys to select 2D Element.
9. **Close:** Press the EXIT key until the Menu System is closed.

5. Storing the Transducer

When you are done fishing, store the transducer according to the control head Installation Guide instructions, using the following guidelines:

- 1a. **If you have an ICE Flasher Series control head,** wipe the cable dry, then tuck the float under the control head, wrap the cable around the cable posts, and store the transducer in the transducer well in the front of the portable bag. You do not have to detach the transducer cable from the control head.

OR...

- 1b. **If you have a Humminbird portable bag,** wipe the cable dry, then unplug the cable from the jumper port and tuck the cable and the transducer in one of the long side pockets in the portable bag.

CAUTION! Although the transducer signal cable is designed to be flexible in cold temperatures, you must store your cable correctly to avoid stressing it. Make sure it is coiled smoothly, with no kinks, and that it is clear of the zippers on the portable bag.

Step 1a - Ice Flasher Storage

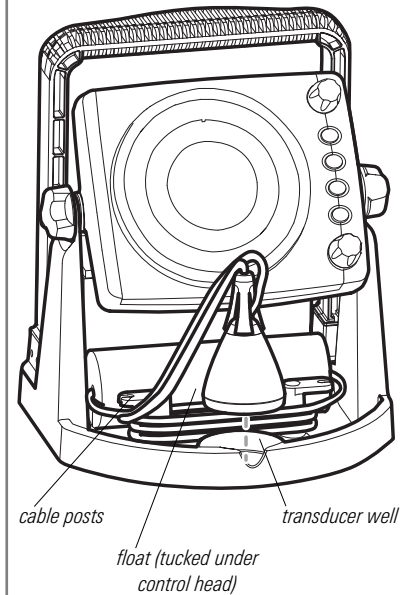

Step 1b - Portable Bag Storage

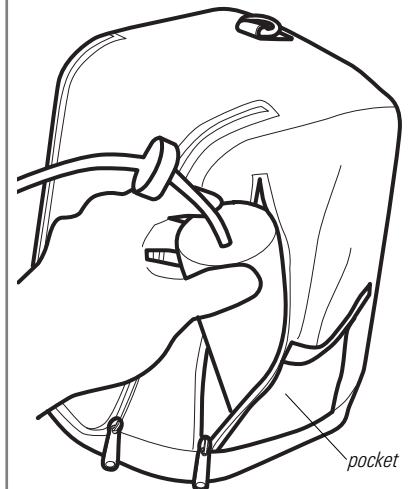

Ice Fishing Transducer

531603-2_D

Maintenance

If your transducer remains in the water for long periods of time, slush, algae and other marine growth can reduce the effectiveness of the transducer. Periodically clean the face of the transducer with a mild, marine-safe and plastic-safe soap or solution.

If your transducer remains out of the water for a long period of time, it may take some time to wet the transducer after it is returned to the water. Small air bubbles can cling to the surface of the transducer and interfere with proper operation. These bubbles will dissipate with time, or you may wipe the face of the transducer with your fingers after the transducer is in the water.

1-Year Limited Warranty

We warrant the original retail purchaser that products made by Humminbird have been manufactured free from defects in materials and workmanship. This warranty is effective for one year from the date of original retail purchase. Humminbird products found to be defective and covered by this warranty will be repaired or replaced free of charge at Humminbird's option and returned to the customer freight prepaid. Humminbird's sole responsibility under this warranty is limited to the repair or replacement of a product that has been deemed defective by Humminbird. Humminbird is not responsible for charges connected with the removal of such product or reinstallation of replaced or repaired parts.

This warranty does not apply to a product that has been:

- Improperly installed;
- Used in an installation other than that recommended in the product installation and operation instructions;
- Damaged or has failed because of an accident or abnormal operation;
- Repaired or modified by entities other than Humminbird.

Please retain your original receipt as a proof of the purchase date. This will be required for in-warranty service.

THIS WARRANTY IS EXPRESSLY IN LIEU OF ANY OTHER WARRANTIES, OBLIGATIONS OR LIABILITIES ON THE PART OF HUMMINBIRD AND WILL BE THE CUSTOMER'S EXCLUSIVE REMEDY, EXCEPT FOR ANY APPLICABLE IMPLIED WARRANTIES UNDER STATE LAW WHICH ARE HEREBY LIMITED IN DURATION TO ONE YEAR FROM THE DATE OF ORIGINAL PURCHASE. IN NO EVENT WILL HUMMINBIRD BE LIABLE FOR ANY INCIDENTAL OR CONSEQUENTIAL DAMAGES FOR BREACH OF ANY EXPRESS OR IMPLIED WARRANTY RELATING TO THE PRODUCTS.

Some states do not allow limitations on an implied warranty, or the exclusion of incidental or consequential damages, so the above exclusions may not apply to you. You may also have other rights, which vary from state to state.

Humminbird Service Policy

Even though you'll probably never need to take advantage of our incredible service policy, it's good to know that we back our products this confidently. We do it because you deserve the best. We will make every effort to repair your unit within three business days from the receipt of your unit at our factory. This does not include shipping time to and from our factory. Units received on Friday are typically shipped by the following Wednesday, units received Monday are typically shipped by Thursday, etc.

All repair work is performed by factory-trained technicians to meet exacting factory specifications. Factory-serviced units go through the same rigorous testing and quality control inspections as new production units.

After the original warranty period, a standard flat rate service charge will be assessed for each repair (physical damage and missing parts are not included). Any repairs made after the original warranty will be warranted for an additional 90 days after service has been performed by our factory technicians.

We reserve the right to deem any product unserviceable when replacement parts are no longer available or impossible to obtain. This Service Policy is valid in the United States only. This applies only to Humminbird products returned to our factory in Eufaula, Alabama. This Service Policy is subject to change without notice.

Returning Your Unit for Service

Before sending your unit in for repair, please contact the factory, either by phone or by email, to obtain a Repair Authorization Number for your unit.

NOTE: Please do not return your Humminbird to the store for service.

Please have your product model name and serial number available before calling the factory. If you contact the factory by e-mail, please include your product model name and serial number in the e-mail, and use Request for Repair Authorization Number for your e-mail subject header. You should include your Repair Authorization Number in all subsequent communications about your unit.

For IN-WARRANTY service, complete the following steps:

- Obtain a Repair Authorization Number from Humminbird Customer Service.
- Tag product with your name, street address, phone number and your assigned Repair Authorization Number.
- Include a brief written description of the problem.
- Include a copy of your receipt (to show proof and date of purchase).
- Return product freight prepaid to Humminbird, using an insured carrier with delivery confirmation.

For OUT-OF-WARRANTY service, complete the following steps:

- Obtain a Repair Authorization Number from Humminbird Customer Service.
- Include payment in the form of credit card number and expiration date, or a money order. Please do not send cash.
- Tag product with your name, street address, phone number and your assigned Repair Authorization Number.
- Include a brief written description of the problem.
- Return product freight prepaid to Humminbird, using an insured carrier with delivery confirmation.

WARNING! Disassembly and repair of this electronic unit should only be performed by authorized service personnel. Any modification of the serial number or attempt to repair the original equipment or accessories by unauthorized individuals will void the warranty.

WARNING! This product contains chemicals known to the State of California to cause cancer and birth defects or other reproductive harm.

ENVIRONMENTAL COMPLIANCE STATEMENT: It is the intention of Johnson Outdoors Marine Electronics, Inc. to be a responsible corporate citizen, operating in compliance with known and applicable environmental regulations, and a good neighbor in the communities where we make or sell our products.

WEEE DIRECTIVE: EU Directive 2002/96/EC "Waste of Electrical and Electronic Equipment Directive (WEEE)" impacts most distributors, sellers, and manufacturers of consumer electronics in the European Union. The WEEE Directive requires the producer of consumer electronics to take responsibility for the management of waste from their products to achieve environmentally responsible disposal during the product life cycle.

WEEE compliance may not be required in your location for electrical & electronic equipment (EEE), nor may it be required for EEE designed and intended as fixed or temporary installation in transportation vehicles such as automobiles, aircraft, and boats. In some European Union member states, these vehicles are considered outside of the scope of the Directive, and EEE for those applications can be considered excluded from the WEEE Directive requirement.



This symbol (WEEE wheelee bin) on product indicates the product must not be disposed of with other household refuse. It must be disposed of and collected for recycling and recovery of waste EEE. Johnson Outdoors Marine Electronics, Inc. will mark all EEE products in accordance with the WEEE Directive. It is our goal to comply in the collection, treatment, recovery, and environmentally sound disposal of those products; however, these requirements do vary within European Union member states. For more information about where you should dispose of your waste equipment for recycling and recovery and/or your European Union member state requirements, please contact your dealer or distributor from which your product was purchased.