

Inside the Hull Mounted Transducer

530509-6_E

Overview

Before you start the installation, we encourage you to read these instructions carefully in order to get the full benefit from your Humminbird® accessory.

NOTE: Your transducer may not look exactly like the transducer shown in the illustrations, but it will mount in exactly the same way.

Installation

There are a number of ways to install a transducer on your boat. Inside the hull mounting of the transducer generally produces good results in single thickness fiberglass hulled boats. Humminbird cannot guarantee depth performance when transmitting and receiving through the hull of the boat, since some signal loss will occur. The amount of loss depends on hull construction and thickness, and the installation.

NOTE: This type of installation requires the use of a slow-cure two-part epoxy. Do not use silicone or any other soft adhesive material to install the transducer, as this material will reduce the sensitivity of the unit. Do not use five-minute epoxy, as it has a tendency to cure before all the air bubbles can be purged, which reduces signal strength.

1. Locating the Transducer Mounting Position

Decide where to install the transducer on the inside of the hull, using the following procedures to find the best location:

1. Observe the outside of the boat hull to find the areas that are mostly free from turbulent water. Avoid ribs, strakes, and other protrusions, as these create turbulence.
2. Make sure that the transducer is located as close to the centerline of the hull and as far aft as possible, so that it will remain in contact with the water even at high speeds.

2. Trial Installation

You will not be able to adjust the mounting position after you install this Inside the Hull transducer. In order to determine the best mounting area (before permanently mounting the transducer), it is best to perform a trial installation first that includes running the boat at various speeds.

1. Plug the transducer into the control head. Press the POWER key to power on. When the control head detects a functioning transducer, it will start Normal mode automatically. Press the VIEW key repeatedly until a Sonar View is displayed on-screen.
2. View the sonar signal at its best by holding the transducer over the side, immersed in the water, so that it is pointing straight down over a known flat bottom. Use the display to benchmark against the sonar signal that will be detected once the transducer is mounted inside the hull.
3. Place the transducer body face down at the identified mounting location inside the hull, oriented as shown in the illustrations (see *Transducers with Directional Bias* and *Transducers without Directional Bias*).

Inside the Hull Installation

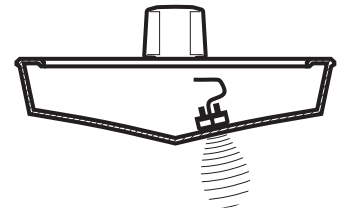

Angled Transducer Installation

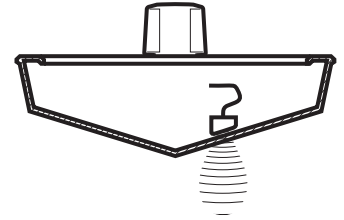

Preferred Mounting Area

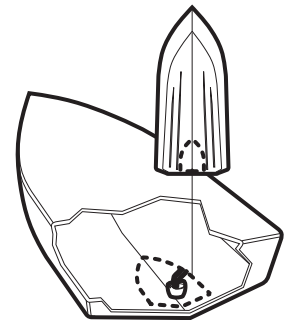
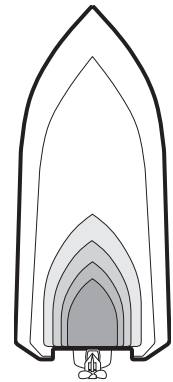

Stepped Hull

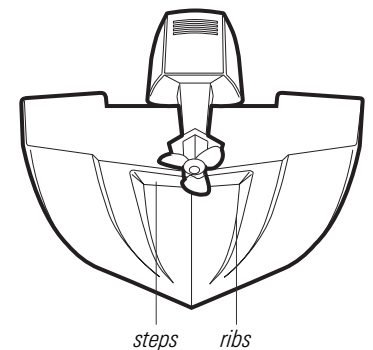

Inside the Hull Mounted Transducer

- Fill the hull with enough water to submerge the transducer body. Use a sand-filled bag or other heavy object to hold the transducer in position.

NOTE: The transducer cannot transmit through air, so the water is necessary to purge any air from between the transducer and the hull, and to fill any voids in the coarse fiberglass surface of the hull.

- View the sonar signal on the control head display and compare it against what you observed in step 2, making sure that the boat is in the same location as it was during your observations in step 2. If the results are comparable, continue to step 6. Otherwise, locate a new position in the hull and repeat steps 3 through 5.
- Run the boat at various speeds and water depths while observing the screen on the control head. If depth performance is required, test the transducer in water at the desired depth. If the performance is acceptable, continue to step 7. If the performance is not acceptable, repeat steps 3 through 6.
- Once you have determined the best mounting location using this procedure, mark the position of the transducer.

3. Installing the Transducer

- Mark the location of the transducer and remove the water from inside the hull. Thoroughly dry the mounting surface.
- Mix an ample quantity of two-part slow-cure epoxy. Coat the face of the transducer and the inside of the hull.
- See the illustrations *Transducers with Directional Bias* and *Transducers without Directional Bias*. Identify your transducer shape to determine how it needs to be oriented inside the hull. (You will install the transducer in step 4.) It is important to consider the following:
 - If you have a Transducer with Directional Bias**, use the illustration to confirm which end of the transducer points forward to the bow of the boat.
 - If you have an angled-style transducer**, position the transducer so it transmits straight down and remains in parallel alignment with the keel.
 - If you have a puck transducer (round)**, it does not need to be set in a certain direction unless it is also an angled-style transducer. See *Transducers without Directional Bias*.
- Press the transducer in place with a slight twisting motion to purge any trapped air from underneath.
- Weight the transducer so that it does not move while the epoxy is curing.
- When the epoxy has cured, no water will be necessary inside the hull, and water or spilled gasoline or oil will not affect the performance of the transducer.

4. Routing the Cable

Use the following instructions to route the cable to the control head or black box sonar, depending on your system configuration.

NOTE: Your boat may have a pre-existing wiring channel or conduit that you can use for the transducer cable.

- Unplug the other end of the transducer cable from the control head.
- Route and secure the cable, avoiding areas where it may be damaged or interfere with normal boating operations.

Transducers with Directional Bias

NOTE: The transducers shown below have a directional bias, and therefore need to be oriented according to the illustration below.

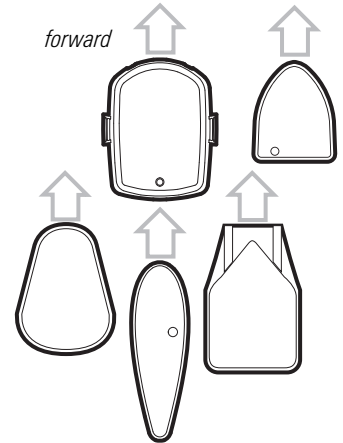

Transducers without Directional Bias

NOTE: The transducers shown below have no directional bias.

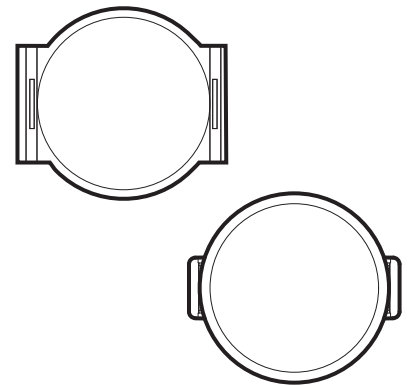

Apply the Epoxy

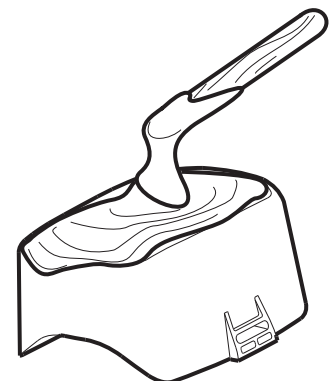

Inside the Hull Mounted Transducer

CAUTION! Do not cut or shorten the transducer cable, and try not to damage the cable insulation. Route the cable as far as possible from any VHF radio antenna cables or tachometer cables to reduce the possibility of interference. If the cable is too short, extension cables are available to extend the transducer cable up to a total of 50'. For assistance, contact Humminbird Customer Service.

CAUTION! Do NOT mount the cables where the connectors could be submerged in water or flooded. If cables are installed in a splash-prone area, it may be helpful to apply dielectric grease to the inside of the connectors to prevent corrosion. Dielectric grease can be purchased separately from a general hardware or automotive store.

- Insert the transducer cable connector into the appropriate port on the control head, cable collector, or black box sonar. See your control head installation guide for details.
 - The cable connectors are labeled, and there are corresponding labels on the cable collector and control head. The connectors are keyed to prevent reversed installation, and insertion should be easy— do not force the connectors into the ports.
 - If the connector on the cable is round, it has a screw nut (see the illustration *Transducer Connectors*). Hand tighten the screw nut to secure the cable connection. Hand tighten only!
- Proceed to *Installing the Temp Probe* (if applicable) or *Setting up the Transducer on the Control Head*.

5. Installing the Temperature Probe (If Applicable)

The Temperature Probe incorporates a temperature-sensitive probe in a high impact plastic housing. The probe is intended for installation on the transom and will work well on almost any boat.

NOTE: The temperature probe is only available on certain models. Contact Customer Service for details.

Supplies: In addition to the parts supplied, you will need a hand drill with various size bits, marine-grade silicone sealant, and various hand tools.

Temperature Probe Mounting Location: Locate an area on the transom of your boat 6" to 8" or farther from the transducer(s). This area must stay in contact with the water at high speeds. Do not mount the sensor directly in front of the propeller or outdrive, and make sure that there are no protrusions such as ribs, rows of rivets, or transducers directly forward of the mounting location, as these may affect the flow of water over the temperature probe.

- Either route the cable from the in-hull mounted transducer over the top of the transom, or drill a 5/8" hole in the transom directly above the sensor, above the waterline.

CAUTION! The temperature probe incorporates a temperature-sensitive probe in a high-impact plastic housing with 10 feet of cable. Do not cut or shorten the temperature probe cable, and try not to damage the cable insulation. The probe is intended for installation on the transom and will work well on almost any boat.

- Assemble the sensor in the clamp, and align it on the transom so the lower edge of the temperature probe sensor is flush with the hull of the boat, and so that it doesn't extend below the hull. Mark the hole location.
- Drill a 1/8" mounting hole approximately 3/4" deep.

NOTE: On fiberglass hulls, it is best to start with a smaller bit and use progressively larger drill bits to reduce the chance of chipping or flaking the outer coating.

- Seal the mounting hole with marine-grade silicone sealant, and attach the sensor to the transom using the provided screw.

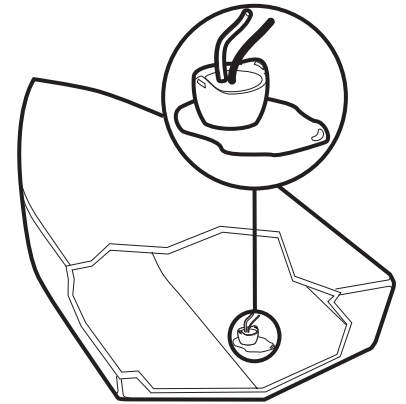

In-Hull Transducer with External Temperature Probe



Transducer Connectors

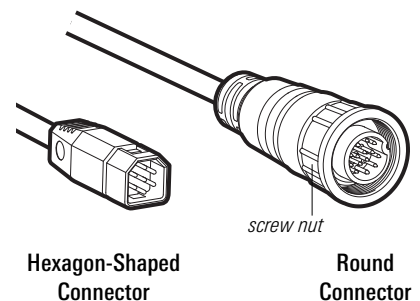

Inside the Hull Mounted Transducer

530509-6_E

5. If a thru-hole is used, an escutcheon plate is included to dress the hole. Place the escutcheon plate over the cable hole and use it as a guide to mark the two escutcheon plate mounting holes. Remove the plate, drill two 9/64" diameter x 5/8" deep holes, then fill all holes with marine-grade silicone sealant. Place the escutcheon plate over the cable hole and attach it with two #8 x 5/8" wood screws.
6. Route and secure the cable by attaching the supplied cable clamps to the transom. Drill one 9/64" diameter x 5/8" deep hole for each cable clamp. Fill the hole with marine-grade silicone sealant, and attach the cable clamp to the transom using a #8 x 5/8" screw.
7. If the connection is correct, the Humminbird unit will begin displaying water temperature immediately. If the gauge fails to read at high speeds, adjust the height of the sensor on the transom of your boat.
8. After final high-speed adjustments have been made, if a thru-hull hole was used, seal the hole with marine-grade silicone sealant.

NOTE: The cabling from your transducer should already be routed from its location to the control head. The cabling from the temperature probe goes into the transducer module and its readings are transferred through the same cable to the control head. Refer to your control head installation guide for more information about the quick disconnect or connector collector included with your control head.

6. Setting up the Transducer on the Control Head

Use the following instructions to set the transducer type in the control head. When you select the transducer type, the related views and menus will be added to the system. **Before you proceed, review the following information:**

- **If your transducer has the round cable connector,** the control head will automatically detect the transducer and configure it with the control head. For additional configuration information, see your control head operations manual. The instructions in this section do not apply to your fishing system.
 - **If your fishfinder is a PiranhaMAX,** or does not include the Transducer Select or Connected Transducer menu option, no further action is required. The transducer will be detected automatically if it is compatible with the control head. See your control head operations manual for details.
1. Press the POWER/LIGHT key to power on the control head.
 2. Press the MENU key. When the control head detects a functioning transducer, it will automatically start Normal operating mode. Follow the on-screen prompts.
 3. **Main Menu:** Press the MENU key twice.
 4. Use the 4-WAY Cursor Control key to select the Sonar tab > Transducer Select or Connected Transducer.
 5. Press the RIGHT or LEFT Cursor keys to select the transducer type (Dual Beam, Quad Beam, etc.). The available menu options are determined by the transducer model you have attached.
 6. **Close:** Press the EXIT key until the Menu System is closed. Your control head is now ready for operation.

Routing the Temp Probe Cable

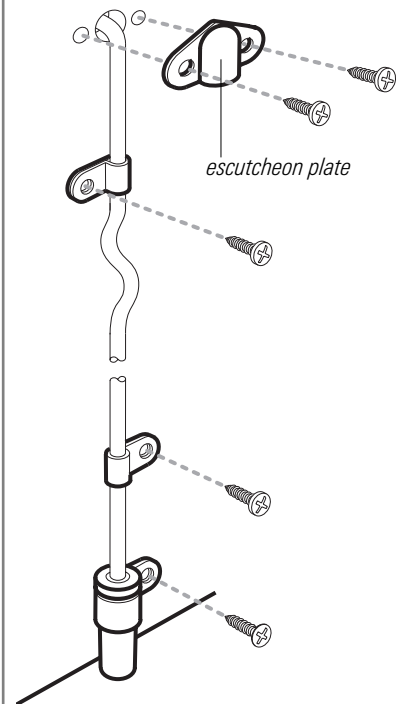

Inside the Hull Mounted Transducer

530509-6_E

Maintenance

If your boat remains in the water for long periods of time, algae and other marine growth can reduce the effectiveness of the transducer. Periodically clean the face of the transducer with a mild, marine-safe and plastic-safe soap or solution.

If your boat remains out of the water for a long period of time, it may take some time to wet the transducer after it is returned to the water. Small air bubbles can cling to the surface of the transducer and interfere with proper operation. These bubbles will dissipate with time, or you may wipe the face of the transducer with your fingers after the transducer is in the water.

1-Year Limited Warranty

We warrant the original retail purchaser that products made by Humminbird have been manufactured free from defects in materials and workmanship. This warranty is effective for one year from the date of original retail purchase. Humminbird products found to be defective and covered by this warranty will be repaired or replaced free of charge at Humminbird's option and returned to the customer freight prepaid. Humminbird's sole responsibility under this warranty is limited to the repair or replacement of a product that has been deemed defective by Humminbird. Humminbird is not responsible for charges connected with the removal of such product or reinstallation of replaced or repaired parts.

This warranty does not apply to a product that has been:

- Improperly installed;
- Used in an installation other than that recommended in the product installation and operation instructions;
- Damaged or has failed because of an accident or abnormal operation;
- Repaired or modified by entities other than Humminbird.

Please retain your original receipt as a proof of the purchase date. This will be required for in-warranty service.

THIS WARRANTY IS EXPRESSLY IN LIEU OF ANY OTHER WARRANTIES, OBLIGATIONS OR LIABILITIES ON THE PART OF HUMMINBIRD AND WILL BE THE CUSTOMER'S EXCLUSIVE REMEDY, EXCEPT FOR ANY APPLICABLE IMPLIED WARRANTIES UNDER STATE LAW WHICH ARE HEREBY LIMITED IN DURATION TO ONE YEAR FROM THE DATE OF ORIGINAL PURCHASE. IN NO EVENT WILL HUMMINBIRD BE LIABLE FOR ANY INCIDENTAL OR CONSEQUENTIAL DAMAGES FOR BREACH OF ANY EXPRESS OR IMPLIED WARRANTY RELATING TO THE PRODUCTS.

Some states do not allow limitations on an implied warranty, or the exclusion of incidental or consequential damages, so the above exclusions may not apply to you. You may also have other rights, which vary from state to state.

Humminbird Service Policy

Even though you'll probably never need to take advantage of our incredible service policy, it's good to know that we back our products this confidently. We do it because you deserve the best. We will make every effort to repair your unit within three business days from the receipt of your unit at our factory. This does not include shipping time to and from our factory. Units received on Friday are typically shipped by the following Wednesday, units received Monday are typically shipped by Thursday, etc.

All repair work is performed by factory-trained technicians to meet exacting factory specifications. Factory-serviced units go through the same rigorous testing and quality control inspections as new production units.

After the original warranty period, a standard flat rate service charge will be assessed for each repair (physical damage and missing parts are not included). Any repairs made after the original warranty will be warranted for an additional 90 days after service has been performed by our factory technicians.

We reserve the right to deem any product unserviceable when replacement parts are no longer available or impossible to obtain. This Service Policy is valid in the United States only. This applies only to Humminbird products returned to our factory in Eufaula, Alabama. This Service Policy is subject to change without notice.

Inside the Hull Mounted Transducer

530509-6_E

Returning your Unit for Service

Before sending your unit in for repair, please contact the factory, either by phone or by email, to obtain a Repair Authorization Number for your unit.

NOTE: Please do not return your Humminbird to the store for service.

Please have your product model name and serial number available before calling the factory. If you contact the factory by e-mail, please include your product model name and serial number in the e-mail, and use Request for Repair Authorization Number for your e-mail subject header. You should include your Repair Authorization Number in all subsequent communications about your unit.

For IN-WARRANTY service, complete the following steps:

- Obtain a Repair Authorization Number from Humminbird Customer Service.
- Tag product with your name, street address, phone number and your assigned Repair Authorization Number.
- Include a brief written description of the problem.
- Include a copy of your receipt (to show proof and date of purchase).
- Return product freight prepaid to Humminbird, using an insured carrier with delivery confirmation.

For OUT-OF-WARRANTY service, complete the following steps:

- Obtain a Repair Authorization Number from Humminbird Customer Service.
- Include payment in the form of credit card number and expiration date, or a money order. Please do not send cash.
- Tag product with your name, street address, phone number and your assigned Repair Authorization Number.
- Include a brief written description of the problem.
- Return product freight prepaid to Humminbird, using an insured carrier with delivery confirmation.

WARNING! This device should not be used as a navigational aid to prevent collision, grounding, boat damage, or personal injury. When the boat is moving, water depth may change too quickly to allow time for you to react. Always operate the boat at very slow speeds if you suspect shallow water or submerged objects.

WARNING! Disassembly and repair of this electronic unit should only be performed by authorized service personnel. Any modification of the serial number or attempt to repair the original equipment or accessories by unauthorized individuals will void the warranty.

WARNING! This product contains chemicals known to the State of California to cause cancer and birth defects or other reproductive harm.

ENVIRONMENTAL COMPLIANCE STATEMENT: It is the intention of Johnson Outdoors Marine Electronics, Inc. to be a responsible corporate citizen, operating in compliance with known and applicable environmental regulations, and a good neighbor in the communities where we make or sell our products.

WEEE Directive: EU Directive 2002/96/EC "Waste of Electrical and Electronic Equipment Directive (WEEE)" impacts most distributors, sellers, and manufacturers of consumer electronics in the European Union. The WEEE Directive requires the producer of consumer electronics to take responsibility for the management of waste from their products to achieve environmentally responsible disposal during the product life cycle.

WEEE compliance may not be required in your location for electrical & electronic equipment (EEE), nor may it be required for EEE designed and intended as fixed or temporary installation in transportation vehicles such as automobiles, aircraft, and boats. In some European Union member states, these vehicles are considered outside of the scope of the Directive, and EEE for those applications can be considered excluded from the WEEE Directive requirement.



This symbol (WEEE wheelie bin) on product indicates the product must not be disposed of with other household refuse. It must be disposed of and collected for recycling and recovery of waste EEE. Johnson Outdoors Marine Electronics, Inc. will mark all EEE products in accordance with the WEEE Directive. It is our goal to comply in the collection, treatment, recovery, and environmentally sound disposal of those products; however, these requirements do vary within European Union member states. For more information about where you should dispose of your waste equipment for recycling and recovery and/or your European Union member state requirements, please contact your dealer or distributor from which your product was purchased.