

SOLIX® SERIES CONTROL HEAD Installation Instructions

Overview

Follow the instructions in this installation guide to gimbal mount the control head. We encourage you to read this guide before starting the installation, so you may understand the installation requirements.

SUPPLIES: In addition to the hardware supplied with your control head, you will need a powered hand drill and various drill bits, flat head screwdriver, pencil, safety glasses and dust mask, marine-grade silicone sealant, dielectric grease (optional), extension cables (optional), Ethernet cables (optional), and accessory cables (optional). Also, see **Connect Power** to determine the type of connection, fuse, and additional equipment you will need for the installation.

Accessories and Ethernet: Accessories and Ethernet equipment are available for purchase at **humminbird**. The installation guides are available with the product, or they can be downloaded from our Web site.

NOTE: For RAM mounting installation, see the FAQ (Frequently Asked Questions) section of our Web site at **humminbird**.

1. Plan the Mounting Location

Pre-assemble the control head to plan the best mounting location.

1. Place 1 metal washer onto each gimbal knob.
2. Place 1 rubber washer onto each gimbal knob.
3. Install the gimbal knobs (with washers) into each side of the control head. Tighten the knobs just enough so you can slide the control head into the gimbal bracket arms.
4. Install the control head into the arms of the bracket mount. Confirm the opening in the gimbal bracket arms faces the rear of the control head. Confirm the ratchets on the bracket and control head fit together.

Assembling the Control Head and Bracket

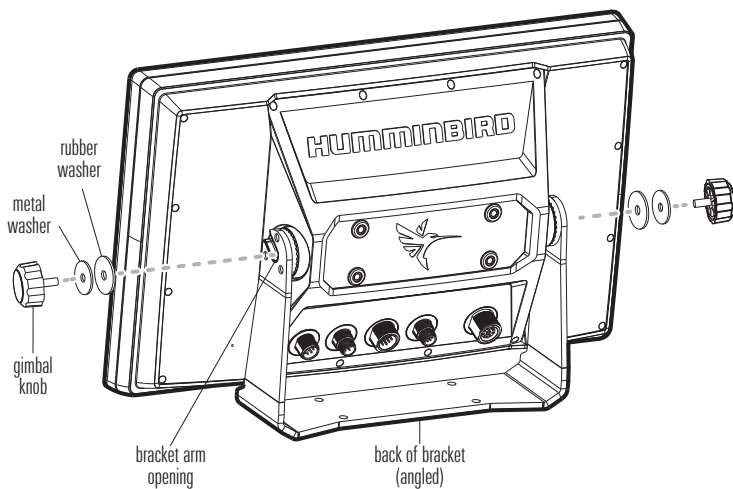

If you prefer to mount the control head overhead, flip the bracket to the top of the control head. The opening in the gimbal bracket arms must face the rear of the control head.

NOTE: Overhead and/or thin panels may require additional hardware (separate purchase required) to securely mount the control head.

Overhead Mount

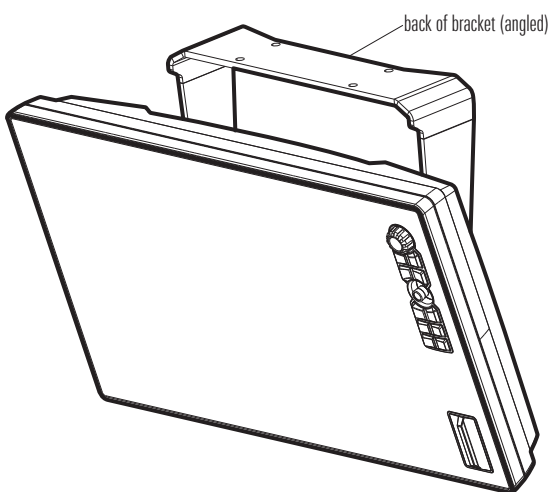

5. Hand-tighten the gimbal knobs to secure the control head to the gimbal bracket.
6. Place the assembled control head in various locations to determine the best mounting location with the following requirements:
 - a stable, protected surface to protect the control head from excessive wave shock, vibration, and water
 - sufficient space for the control head tilt range
 - visibility during operation, as well as easy installation and removal
 - access above and below the mounting surface to pass the cables through to the control head
 - space for the 1 1/4" (31.75 mm) cable hole located 2" to 4" (50 to 100 mm) behind the chosen mounting location
7. Test route all cables (transducer, power, Ethernet, accessories) to the control head mounting location. Leave enough cable length for the control head tilt range.
8. After you have selected the mounting location, loosen the gimbal knobs and remove the control head from the gimbal bracket.

2. Install the Gimbal Bracket

1. Place the gimbal bracket in the chosen position on the mounting surface. Make sure the straight part of the bracket faces forward. The opening in the

gimbal bracket arms must face the rear of the control head. See the illustration *Assembling the Control Head and Bracket* for more information.

2. Mark the four mounting screw locations using a pencil or center punch.
3. Set the gimbal bracket aside. Drill the four mounting screw holes using a 5/32" (4 mm) drill bit.
4. **Cable Hole:** Mark and drill a 1 1/4" (31.75 mm) hole 2" to 4" (50 to 100 mm) behind the bracket. You will use this hole for routing the cables to the control head in another section.
5. Proceed to *Traditional Mount* or *Overhead Mount*.

Traditional Mount

1. Place the bracket on the mounting surface aligned with the drilled holes.
2. Fill the mounting holes with marine-grade silicone sealant.
3. Place one flat washer onto each #10 x 1" wood screw. Insert the four screws with washers into the mounting holes and tighten them until they are secure (see the illustration *Installing the Gimbal Bracket*). **Hand-tighten only!**

Installing the Gimbal Bracket

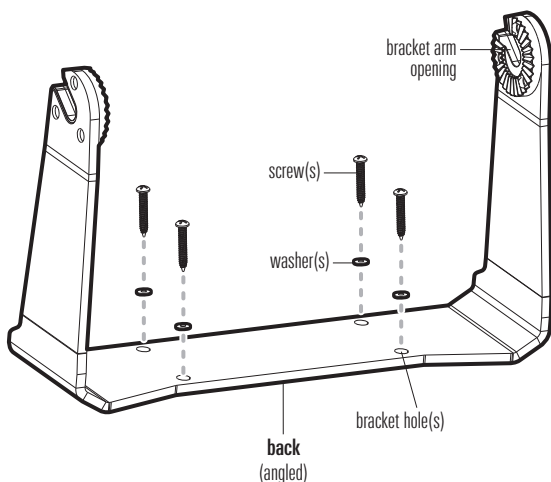

Bracket Hole Pattern Measurements

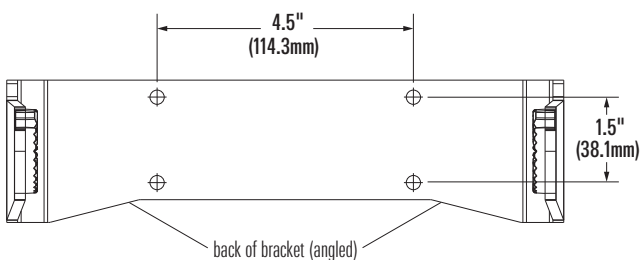

4. Place the control head back onto the gimbal bracket (see *Plan the Mounting Location* for details). Adjust the control head viewing angle as needed and tighten the gimbal knobs until the assembly is secured. **Hand-tighten only!**

Overhead Mount



NOTE: Overhead and/or thin panels may require additional hardware (separate purchase required) to securely mount the control head.

1. Place the bracket on the mounting surface aligned with the drilled holes. Fill one hole with marine-grade silicone sealant.
2. Place one flat washer on a #10 x 1" wood screw and install the screw into the hole (see the illustration *Installing the Gimbal Bracket*). Repeat for the remaining three holes.
3. Tighten each screw until it is secure.
4. Place the control head back onto the gimbal bracket (see *Plan the Mounting Location* for details). Adjust the control head viewing angle as needed and tighten the gimbal knobs until the assembly is secured. **Hand-tighten only!**

3. Connect Power

It is important to review the following information before you start the power installation:

- **Cable Length:** A 6' (2 m) long power cable is included. You may shorten or lengthen the cable using 18 gauge multi-stranded copper wire. See the *Recommended Power Cable Extension Information* table for details.

Recommended Power Cable Extension Information

| Extension Length | Wire Gauge |
|------------------|------------|
| 1 to 6 ft | 18 AWG |
| 6 to 12 ft | 14 AWG |
| 12 to 24 ft | 12 AWG |

Please consult a U.S. Coast Guard ABYC-approved wire gauge diagram or a certified NMEA Marine Electronics Installer.

- **Power Supply:** The control head must be connected to a 12 VDC power supply using the fuse size and type shown in the *Required Fuse Information* table.

Required Fuse Information (separate purchase required)

| Model | Fuse Size | Fuse Type |
|----------|-----------|-----------------------------|
| SOLIX 10 | 5 A | slow-blow or MDL equivalent |
| SOLIX 12 | 5 A | slow-blow or MDL equivalent |
| SOLIX 15 | 7.5 A | slow-blow or MDL equivalent |

- **Fuse Panel or Battery:** The control head power cable can be connected to the electrical system of the boat at the fuse panel (usually located near the console), or directly to the battery. In order to minimize the potential for interference with other marine electronics, a separate power source (such as a second battery) may be necessary.

WARNING! Some boats have 24 or 36 Volt electric systems, but the control head **MUST** be connected to a 12 VDC power supply.

WARNING! Make sure that the power cable is disconnected from the control head at the beginning of this procedure.

WARNING! Humminbird® is not responsible for over-voltage or over-current failures. The control head must have adequate protection through the proper selection and installation of the required fuse shown in the **Required Fuse Information** table.

1. Confirm that the power cable is disconnected from the control head.
2. Connect the power cable wires to the fuse panel or battery as follows:

Fuse Terminal Connection: Use crimp-on type electrical connectors (not included) that match the terminal on the fuse panel. Attach the black wire to ground (–), and the red wire to positive (+) 12 VDC power. Install the required fuse (as shown in the **Required Fuse Information** table).

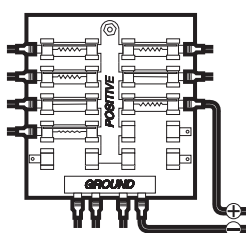

Battery Connection: Install an inline fuse holder (not included) and the required fuse (as shown in the **Required Fuse Information** table). Attach the black wire to ground (–), and the red wire to positive (+) 12 VDC power.

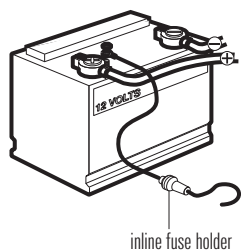

NOTE: For multi-control head installations and troubleshooting information, download the Power Troubleshooting Guide from our Web site at **humminbird**. Also, see the control head operations manual to set the Low Battery Alarm and use Standby Mode to conserve power.



NOTE: If you have a trolling motor, it is important to keep the control head power and trolling motor power as separate as possible.

4. Route and Connect the Cables

1. **Sonar:** Proceed to your transducer installation guide and follow the instructions to install the transducer.
2. **Accessories (optional):** Install accessories using the guides provided with them.
3. **Ethernet (optional):** Install Ethernet cables and hardware using the Ethernet Installation Guide.

NMEA 2000® Port (optional)

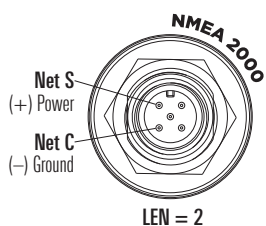

NOTE: The installation guides for Ethernet and optional-purchase accessories are available with your product, and they can be downloaded from our Web site at **humminbird**.

4. Route all cables to the control head. Your boat may have a pre-existing wiring channel or conduit that you can follow. Route the cables as far as practical from the antenna cable of VHF radios or tachometer cables to reduce the possibility of interference.

CAUTION! Do NOT mount the cables where the connectors could be submerged in water or flooded. If cables are installed in a splash-prone area, it may be helpful to apply dielectric grease to the inside of the connectors to prevent corrosion. Dielectric grease can be purchased separately from a general hardware or automotive store.

5. Pass the cables through the cable hole.

Routing the Cables Behind the Bracket

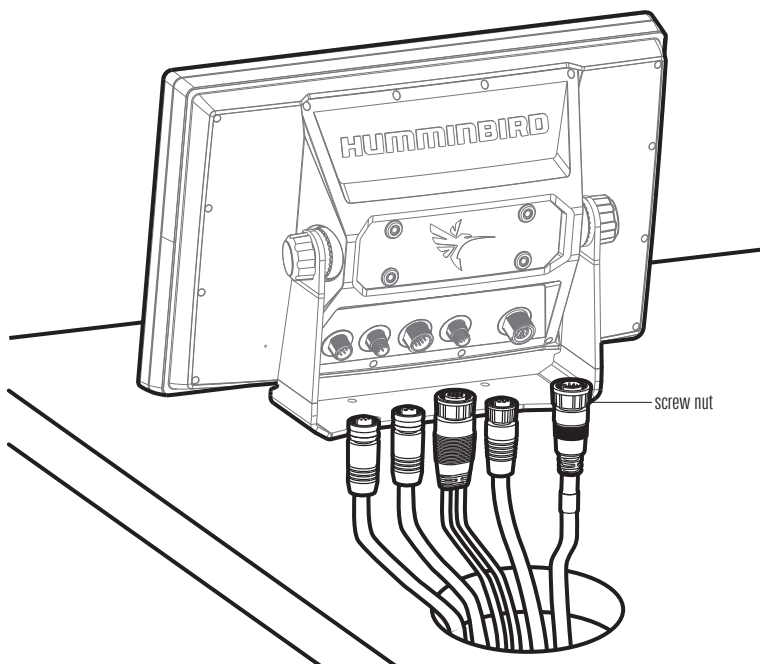

6. Connect each cable to the appropriate ports on the control head. The ports are labeled, and the connectors are keyed to prevent incorrect installation.
7. Hand-tighten the screw nut on each cable to secure the connection. See the illustration **Routing the Cables Behind the Bracket**.

Cover any unused ports to prevent potential damage.

8. Confirm there is enough cable slack to allow for the control head to pivot through its full tilt range and for connecting or disconnecting the cables. Use nylon cable ties (not included) to secure the cables and create a clean assembly.



NOTE: If there is excess cable that needs to be gathered at one location, dress the cable routed from both directions so that a single loop is left extending from the storage location. Doubling the cable up from this point, form the cable into a coil. Storing excess cable using this method can reduce electronic interference.

Storing Excess Cable

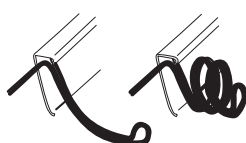

5. Test the System Installation

1. Press the **POWER** key to turn on the control head. Select **Start Normal Mode**. When you power on the control head for the first time, use the Setup Guide to configure the unit. After initial setup, these settings can be adjusted from the Home screen > Settings or Setup Guide.
2. Select **Begin Manual Setup**.



OR

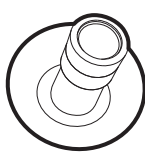

+



3. Select **Angler mode**. Follow the on-screen prompts to configure the unit. **Angler mode** is the fastest way to configure the control head with less menu settings to get in the way. Use the smart defaults without the need to customize your unit.
4. After the setup is confirmed, press the Home key .
5. Select Settings > Network > System Info.

GPS: Confirm the GPS is listed as **Enhanced Fix** or **3D Fix**. Confirm that a latitude/longitude position is displayed in the **Position** digital readouts section.

Accessories: Review the list to confirm accessories are listed as connected. If an accessory is not detected, check cable connections, confirm power is turned on, and review the installation guide. The temp/speed accessory will be detected only if the paddlewheel has moved.



NOTE: You can access sensor port settings from Settings > Network. To turn on NMEA 0183 output, select NMEA 0183 sentences, set the baud rate, etc., select Settings > Network > NMEA 0183.

6. Press the Home key.
7. **Sonar Test:** Test and finalize the transducer installation using the instructions in the transducer installation guide.
8. When the transducer test and installation are completed, the SOLIX control head is ready for on-the-water operation. Use the **Home screen** to access settings, alarms, views, and tools. The options are determined by the equipment attached to the control head network.

Important Notices



WARNING! Disassembly and repair of this electronic unit should only be performed by authorized service personnel. Any modification of the serial number or attempt to repair the original equipment or accessories by unauthorized individuals will void the warranty.



WARNING! This device should not be used as a navigational aid to prevent collision, grounding, boat damage, or personal injury. When the boat is moving, water depth may change too quickly to allow time for you to react. Always operate the boat at very slow speeds if you suspect shallow water or submerged objects.

FCC NOTICE: This device complies with Part 15 of the FCC Rules. Operation is subject to the following two conditions: (1) this device may not cause harmful interference, and (2) this device must accept any interference received, including interference that may cause undesired operation.



CAUTION! This equipment has been tested and found to comply with the limits for a Class B digital device, pursuant to Part 15 of the FCC Rules. These limits are designed to provide reasonable protection against harmful interference in a residential installation. This equipment generates, uses and can radiate radio frequency energy and, if not installed and used in accordance with the instructions, may cause harmful interference to radio communications. However, there is no guarantee that interference will not occur in a particular installation. If this equipment does cause harmful interference to radio or television reception, which can be determined by turning the equipment off and on, the user is encouraged to try to correct the interference by one or more of the following measures:

- Reorient or relocate the receiving antenna.
- Increase the separation between the equipment and receiver.
- Connect the equipment into an outlet on a circuit different from that to which the receiver is connected.
- Consult the dealer or an experienced radio/TV technician for help.

Class B Device (Broadcasting and communication equipment for home):



CAUTION! This equipment is home use (Class B) electromagnetic wave suitability equipment and to be used at home and it can be used in all areas.

ENVIRONMENTAL COMPLIANCE STATEMENT: It is the intention of Johnson Outdoors Marine Electronics, Inc. to be a responsible corporate citizen, operating in compliance with known and applicable environmental regulations, and a good neighbor in the communities where we make or sell our products.

WEEE DIRECTIVE: EU Directive 2002/96/EC "Waste of Electrical and Electronic Equipment Directive (WEEE)" impacts most distributors, sellers, and manufacturers of consumer electronics in the European Union. The WEEE Directive requires the producer of consumer electronics to take responsibility for the management of waste from their products to achieve environmentally responsible disposal during the product life cycle.

WEEE compliance may not be required in your location for electrical & electronic equipment (EEE), nor may it be required for EEE designed and intended as fixed or temporary installation in transportation vehicles such as automobiles, aircraft, and boats. In some European Union member states, these vehicles are considered outside of the scope of the Directive, and EEE for those applications can be considered excluded from the WEEE Directive requirement.



This symbol (WEEE wheelee bin) on product indicates the product must not be disposed of with other household refuse. It must be disposed of and collected for recycling and recovery of waste EEE. Johnson Outdoors Marine Electronics, Inc. will mark all EEE products in accordance with the WEEE Directive. It is our goal to comply in the collection, treatment, recovery, and environmentally sound disposal of those products; however, these requirements do vary within European Union member states. For more information about where you should dispose of your waste equipment for recycling and recovery and/or your European Union member state requirements, please contact your dealer or distributor from which your product was purchased.

Humminbird® and SOLIX® are trademarked by or registered trademarks of Johnson Outdoors Marine Electronics, Inc.

NMEA 2000® is a registered trademark of the National Marine Electronics Association.