



## TROLLING MOTOR TRANSDUCER INSTALLATION GUIDE

Use the instructions in this guide to install the transducer on your trolling motor.

**WARNING!** Disconnect the trolling motor from all sources of electrical power before you start the installation.

**CAUTION!** Do NOT install the hose clamps where they can come into contact with the trolling motor support rails.

**NOTE:** The procedures and features described in this guide are subject to change without notice. This guide was written in English and may have been translated to another language. Humminbird® is not responsible for incorrect translations or discrepancies between documents.

**NOTE:** Your transducer may not look exactly like the transducer shown in the illustrations, but it will mount in exactly the same way.

### INSTALLATION PREPARATION

**Install the control head before you start the transducer installation.** See the control head installation guide.

**Supplies:** In addition to the supplied hardware, you will need various hand tools, including a Phillips head screwdriver. If you purchased a transducer mount adapter kit, you will also need your original transducer for this installation. You may also need extension cables and hardware for routing the cable to the control head.

**Read the instructions in this transducer guide completely** to understand the mounting guidelines before starting the installation.

**Disconnect Power:** Disconnect the trolling motor from all sources of electrical power before you start the installation.

**Test Route the Cable Installation:** Test route the transducer cable connector to the control head and confirm that the cable is long enough for the planned route. Your boat may have a pre-existing wiring channel or conduit that you can use for the transducer cable. See section 4: *Route the Transducer Cable* for requirements.

**WARNING!** Do not route the cable where it can be damaged by the trolling motor during operation or while stowing and deploying.

**NOTE:** If the cable is too short, extension cables are available.

### Installation Overview

#### 1. Test the Transducer Prior to Installation

Prior to installation, test the transducer to make sure that no damage occurred during shipping.

1. Confirm the control head is connected to power. See your control head installation guide for instructions.
2. Connect the transducer cable to the control head. See section 4: *Route the Transducer Cable*.
3. Lower the transducer into the water.
4. **Power On:** Press the POWER key to turn on the control head.  
If the transducer is detected, the control head will start Normal mode.
5. Select a 2D Sonar View to display on-screen.

If the bottom is visible on-screen with a digital depth readout, the transducer is working properly.

6. **Power Off:** Press and hold the POWER key.
7. Remove the transducer from the water.
8. Disconnect the transducer cable from the control head.

#### 2. Install the Mounting Bracket

Follow the instructions below to install the transducer mounting bracket on the transducer.

**WARNING!** Disconnect the trolling motor from all sources of electrical power before you start the installation.

**WARNING!** Confirm that the trolling motor is properly secured to the boat and will not shift during the installation.

1. Align the rounded end of the mounting bracket with the rounded end of the transducer.

2. Thread the cable connector on the transducer cable up through the cable slot on the mounting bracket.
3. Align the screw holes on the mounting bracket with the screw holes on the top of the transducer and install the lock washers and #8-32 7/16" Phillips head screws (included) as shown in the illustrations *Installing the Mounting Bracket*. Hand tighten only.

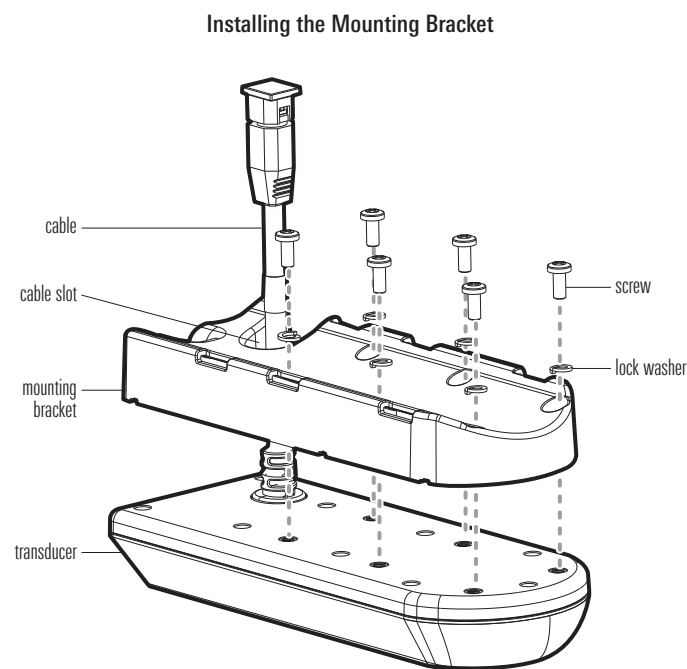

Installing the Mounting Bracket

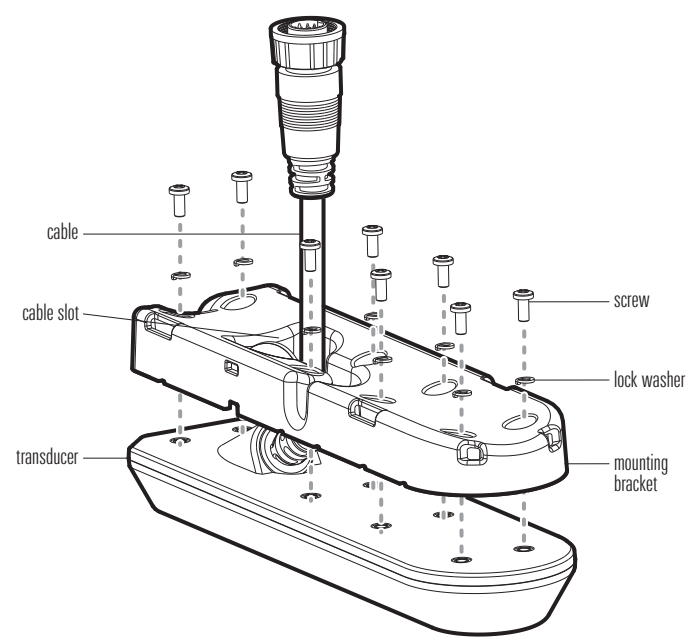

#### 3. Mount the Transducer onto the Trolling Motor

1. Use the following guidelines to mount the transducer on the trolling motor:
  - Confirm the transducer is oriented in the trolling motor's direction of travel.
  - Position the transducer on the underside of the motor housing with the front of the transducer facing away from the propeller.
  - Align the slot in the mounting bracket with the skeg of the trolling motor.
  - Confirm the transducer cable is correctly routed through the cable slot on the mounting bracket, so that the transducer will mount flush against the motor housing.

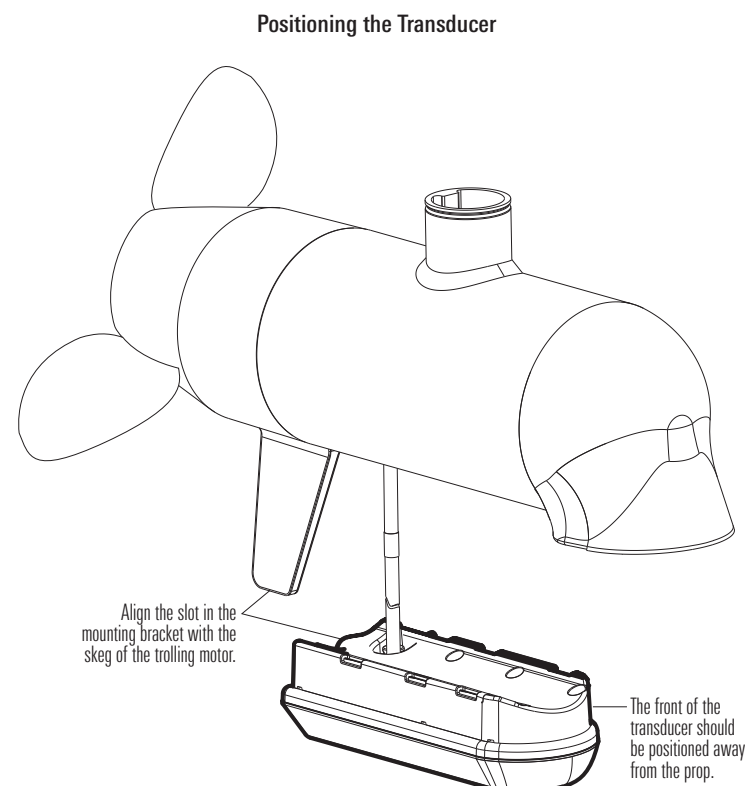

2. Fit each hose clamp through one of the slots on the mounting bracket, as shown in the illustration *Attaching the Transducer*. Pull each hose clamp around the motor housing and hand tighten.

**CAUTION!** Do NOT install the hose clamps where they can come into contact with the trolling motor support rails.

Attaching the Transducer

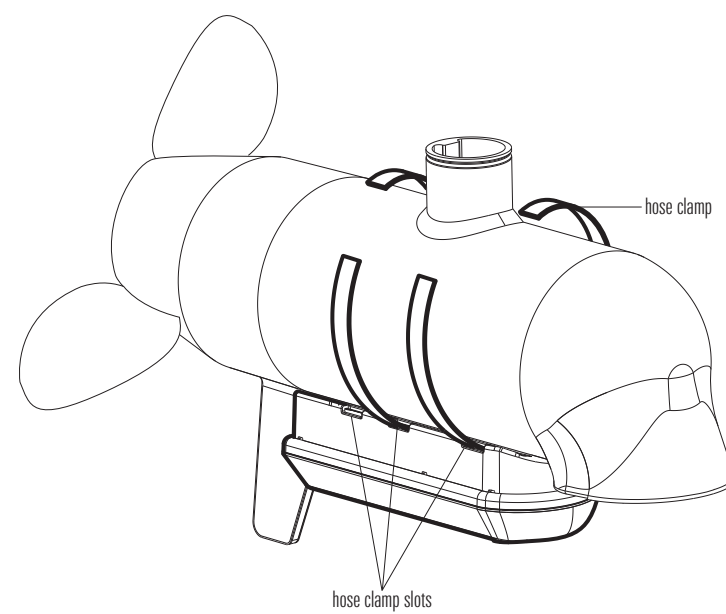

**NOTE:** As you tighten the hose clamps, make sure the transducer stays properly aligned with the motor housing.

3. Confirm that the transducer is secured to the motor housing and will not slip off during operation.

#### 4. Route the Transducer Cable

As you route the cable from the trolling motor to the boat, it is important to secure the cable to the trolling motor shaft using the cable ties provided to prevent the cable from getting pinched or cut when the motor is stowed or deployed. As you route the cable to the control head, leave sufficient slack in the cable to allow for full movement and retraction of the trolling motor during normal operation.

**NOTE:** Your boat may have a pre-existing wiring channel or conduit that you can use for the transducer cable.

**NOTE:** If the cable is too short, extension cables are available. Contact Humminbird Technical Support for more information.

1. Review the *Routing the Cable* illustrations below and determine the best cable routing method for your installation:

**If the base of the cable is closely aligned with the motor shaft,** you can route the cable directly up the shaft as illustrated in *Routing the Cable: Option 2*. Proceed to step 3.

**If the base of the cable is farther away from the motor shaft,** it must be secured to the transducer as illustrated in *Routing the Cable: Option 1*. Proceed to step 2.

2. **Optional:** Locate the cable tie slot on the mounting bracket. Route the transducer cable to the slot and secure it using a cable tie.
3. Route the transducer cable up the motor shaft and secure it using the cable ties provided.

Routing the Cable: Option 1

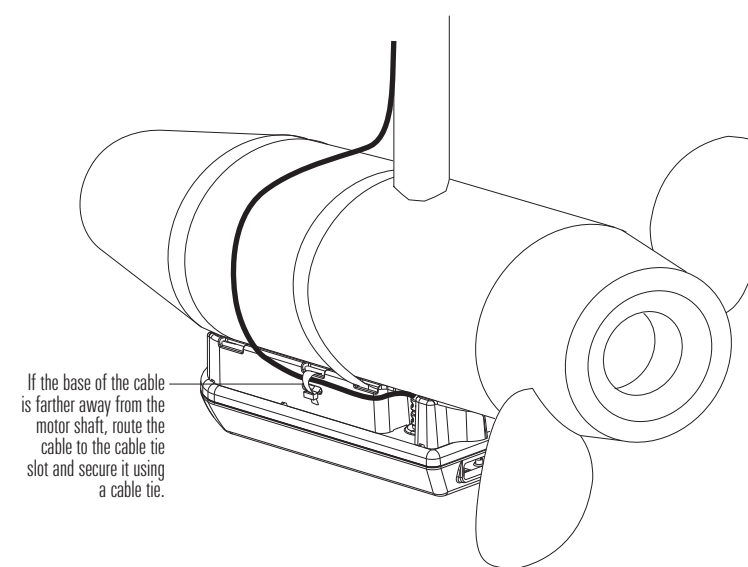

Routing the Cable: Option 2

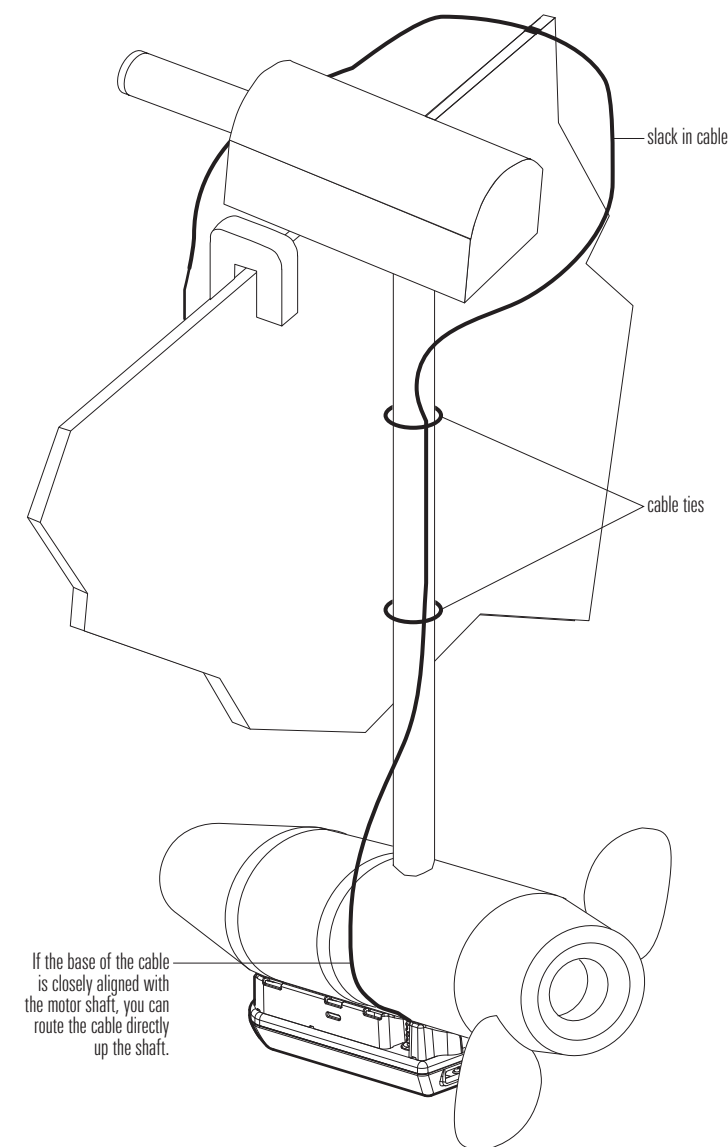

4. Route the transducer cable connector to the control head along the planned route (see the *Preparation* section).

**CAUTION!** Do not cut or shorten the transducer cable, and try not to damage the cable insulation. Route the cable as far as possible from any VHF radio antenna cables or tachometer cables to reduce the possibility of interference.

**CAUTION!** Do NOT mount the cables where the connectors could be submerged in water or flooded. If cables are installed in a splash-prone area, it may be helpful to apply dielectric grease to the inside of the connectors to prevent corrosion. Dielectric grease can be purchased separately from a general hardware or automotive store.

#### 5. Connect the Cable

1. Connect the transducer cable to the transducer port on the control head.

The connector is keyed to prevent reversed installation, and insertion should be easy. Do not force the connectors into the ports.

**If the cable connector is round,** hand-tighten the screw nut to secure the cable connection. **Hand-tighten only!**

**NOTE:** See your control head installation guide for details.

Transducer Connectors

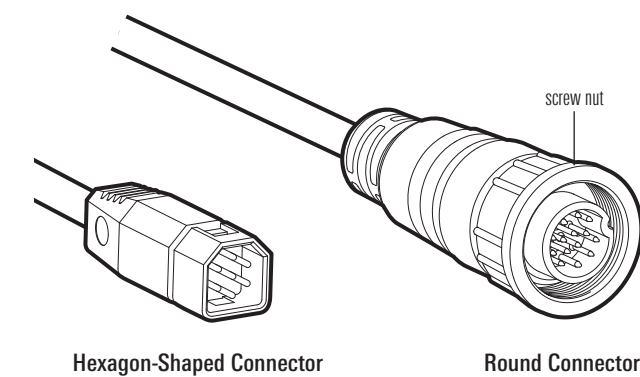

#### 6. Test and Finish the Installation

When you have installed the trolling motor transducer and have routed all the cables, you must perform a final test to verify installation. Testing should be performed with the boat in water deeper than 2 feet. The transducer should be fully submerged because the sonar signal cannot pass through air.

**NOTE:** Make sure the trolling motor is reconnected to the power source before performing this procedure.

1. Power on the control head.
2. Select a 2D sonar view to display on-screen.

If the bottom is visible on-screen with a digital depth readout, the transducer is working properly.

**NOTE:** The transducer must be submerged in water for reliable transducer detection.

### MAINTENANCE

If your transducer remains in the water for long periods of time, slush, algae and other marine growth can reduce the effectiveness of the transducer. Periodically clean the face of the transducer with a mild, marine-safe and plastic-safe soap or solution.

If your transducer remains out of the water for a long period of time, it may take some time to wet the transducer after it is returned to the water. Small air bubbles can cling to the surface of the transducer and interfere with proper operation. These bubbles will dissipate with time, or you may wipe the face of the transducer with your fingers after the transducer is in the water.

### Important Notices

**WARNING!** Disassembly and repair of this electronic unit should only be performed by authorized service personnel. Any modification of the serial number or attempt to repair the original equipment or accessories by unauthorized individuals will void the warranty.

**NOTE:** Product specifications and features are subject to change without notice.

**ENVIRONMENTAL COMPLIANCE STATEMENT:** It is the intention of Johnson Outdoors Marine Electronics, Inc. to be a responsible corporate citizen, operating in compliance with known and applicable environmental regulations, and a good neighbor in the communities where we make or sell our products.

**WEEE DIRECTIVE:** EU Directive 2002/96/EC "Waste of Electrical and Electronic Equipment Directive (WEEE)" impacts most distributors, sellers, and manufacturers of consumer electronics in the European Union. The WEEE Directive requires the producer of consumer electronics to take responsibility for the management of waste from their products to achieve environmentally responsible disposal during the product life cycle.

WEEE compliance may not be required in your location for electrical & electronic equipment (EEE), nor may it be required for EEE designed and intended as fixed or temporary installation in transportation vehicles such as automobiles, aircraft, and boats. In some European Union member states, these vehicles are considered outside of the scope of the Directive, and EEE for those applications can be considered excluded from the WEEE Directive requirement.