

HELIX™ SERIES CONTROL HEAD INSTALLATION GUIDE

Overview

Follow the instructions in this installation guide to gimbale mount the control head. We encourage you to read this guide before starting the installation, so you may understand the installation requirements.

SUPPLIES: In addition to the hardware supplied with your control head, you will need a powered hand drill and various drill bits, Phillips head screwdriver, flat head screwdriver, pencil, safety glasses and dust mask, marine-grade silicone sealant, dielectric grease (optional), extension cables (optional), Ethernet cables (optional), and accessory cables (optional). Also, see **Connect Power** to determine the type of connection, fuse size, and additional equipment you will need for the installation.

Accessories and Ethernet: Accessories and Ethernet equipment are available for purchase. The installation guides are available with the product, or they can be downloaded from our Web site.

1. Plan the Mounting Location

1. Install the gimbal knobs into each side of the control head. Tighten the knobs just enough so you can slide the control head into the gimbal bracket arms.

Assembling the Control Head and Bracket

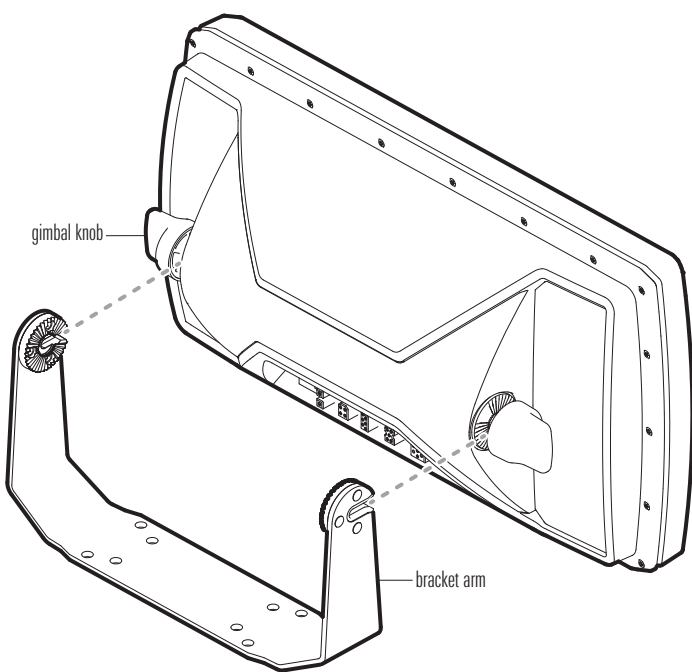

NOTE: If you prefer to mount the control head overhead, flip the bracket to the top of the control head. The opening in the gimbal bracket arms must face the rear of the control head.

2. Place the assembled control head in various locations to determine the best mounting location with the following requirements:
 - a stable, protected surface to protect the control head from excessive wave shock, vibration, and water
 - sufficient space for the control head tilt range
 - visibility during operation, as well as easy installation and removal
 - access above and below the mounting surface to pass the cables through to the control head
 - space for the 1" (25 mm) cable hole located 2" to 4" (50 to 100 mm) behind the chosen mounting location
3. Test route all cables (transducer, power, Ethernet, accessories) to the control head mounting location. Leave enough cable length for installing the cable tray and for the control head tilt range.
4. After you have selected the mounting location, loosen the gimbal knobs and remove the control head from the gimbal bracket.

2. Install the Gimbal Bracket

1. Place the gimbal bracket in the chosen position on the mounting surface. Mark the four outer mounting screw locations using a pencil or center punch.

NOTE: The outer set of mounting holes is recommended. You may use the inside set of mounting holes if necessary.
2. Set the gimbal bracket aside. Drill the four mounting screw holes using a 5/32" (4 mm) drill bit.
3. **Cable Hole:** Mark and drill a 1" (25 mm) hole 2" to 4" (50 to 100 mm) behind the bracket. You will use this hole for routing the cables to the control head in another section.
4. Place the bracket on the mounting surface aligned with the drilled holes. Fill the mounting holes with marine-grade silicone sealant.
5. Place one flat washer onto each #10 x 1" wood screw. Insert the four screws with washers into the mounting holes (see the illustration **Installing the Gimbal Bracket**). **Hand tighten only!**

Installing the Gimbal Bracket

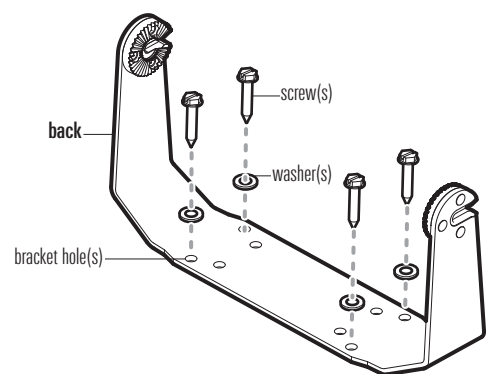

Bracket Hole Pattern Measurements

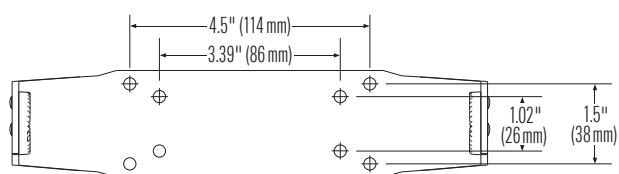

3. Connect Power

It is important to review the following information before you start the power installation:

- **Cable Length:** A 6' (2 m) long power cable is included. You may shorten or lengthen the cable using 18 gauge multi-stranded copper wire. See the **Recommended Power Cable Extension Information** table for details.

Recommended Power Cable Extension Information

Extension Length	Wire Gauge
1 to 6 ft	18 AWG
6 to 12 ft	14 AWG
12 to 24 ft	12 AWG

Please consult a U.S. Coast Guard ABYC-approved wire gauge diagram or a certified NMEA Marine Electronics Installer.

- **Power Supply:** The control head must be connected to a 12 VDC power supply using the fuse size shown in the **Required Fuse Size** table.

Required Fuse Size

Model	Fuse Size
HELIX 9	3A
HELIX 9 G2N	4A
HELIX 10	3A
HELIX 10 G2N	4A
HELIX 12	4A
HELIX 12 G2N	5A

- **Fuse Panel or Battery:** The control head power cable can be connected to the electrical system of the boat at the fuse panel (usually located near the console), or directly to the battery. In order to minimize the potential for interference with other marine electronics, a separate power source (such as a second battery) may be necessary.

WARNING! Some boats have 24 or 36 Volt electric systems, but the control head **MUST** be connected to a 12 VDC power supply.

WARNING! Make sure that the power cable is disconnected from the control head at the beginning of this procedure.

WARNING! Humminbird® is not responsible for over-voltage or over-current failures. The control head must have adequate protection through the proper selection and installation of the fuse size shown in the **Required Fuse Size** table.

1. Confirm that the power cable is disconnected from the control head.
2. Connect the power cable wires to the fuse panel or battery as follows:

Fuse Terminal Connection: Use crimp-on type electrical connectors (not included) that match the terminal on the fuse panel. Attach the black wire to ground (–), and the red wire to positive (+) 12 VDC power. Install the required fuse (as shown in the **Required Fuse Size** table).

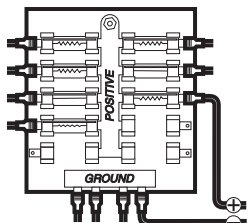

Battery Connection: Install an inline fuse holder (not included) and the required fuse (as shown in the **Required Fuse Size** table). Attach the black wire to ground (–), and the red wire to positive (+) 12 VDC power.

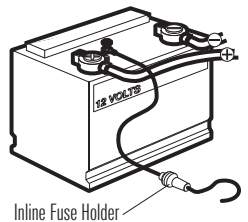

NOTE: For multi-control head installations and troubleshooting information, download the Power Troubleshooting Guide from our Web site. Also, see the Operations Summary Guide to set the Low Battery Alarm and use Standby Mode to conserve power.

4. Route the Cables to the Control Head

1. **Sonar:** Proceed to your transducer installation guide and follow the instructions to install the transducer.
2. **Accessories (optional):** Install accessories using the guides provided with them.
3. **Ethernet (optional):** Install Ethernet cables and hardware using the Ethernet Installation Guide.

NOTE: The installation guides for Ethernet and optional-purchase accessories are available with your product, and they can be downloaded from our Web site.

4. Route all cables to the control head. Your boat may have a pre-existing wiring channel or conduit that you can follow. Route the cables as far as practical from the antenna cable of VHF radios or tachometer cables to reduce the possibility of interference.

CAUTION! Do NOT mount the cables where the connectors could be submerged in water or flooded. If cables are installed in a splash-prone area, it may be helpful to apply dielectric grease to the inside of the connectors to prevent corrosion. Dielectric grease can be purchased separately from a general hardware or automotive store.

5. Pass the cables through the cable hole.

Routing the Cables Behind the Bracket

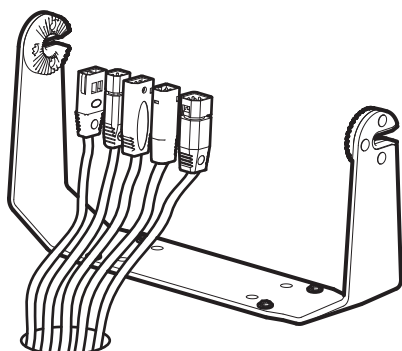

5. Assemble the Cable Tray

The cable tray is an important part of the control head installation. It secures the cables and protects them from potential damage.

1. Use a Phillips head screwdriver to remove the screws from the bottom of the cable tray.
2. **Hold the cable tray together and turn it over**, so the Humminbird logo is facing up. Lift the cover and set it aside.

Removing the Screws

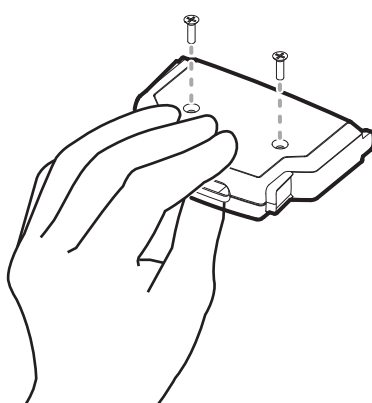

Turning over the Cable Tray

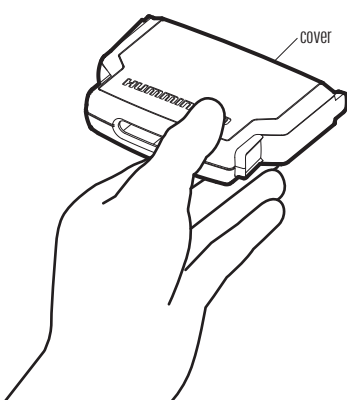

3. See the illustration **Locating the Cable Tray Slots**. Insert each cable connector into the correct slots in the tray.

Each slot is shaped specifically for each connector, and insertion should be easy. Route the cables using the grooves in the tray.

Locating the Cable Tray Slots

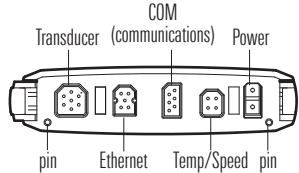

Inserting the Cable Connectors into the Cable Tray

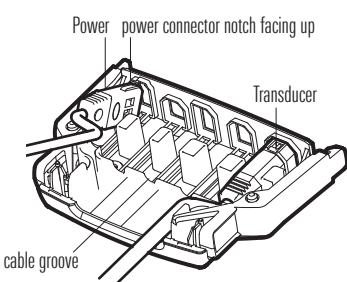

CAUTION! It is important to place the connectors into the correct slots and right side up. See the illustration **Locating the Cable Tray Slots** for details.

4. Place the cover onto the tray. Hold the tray together and turn it over.

If the cable tray arms fall out, see the illustration **Assembling the Cable Tray** to put them back in place.

Assembling the Cable Tray

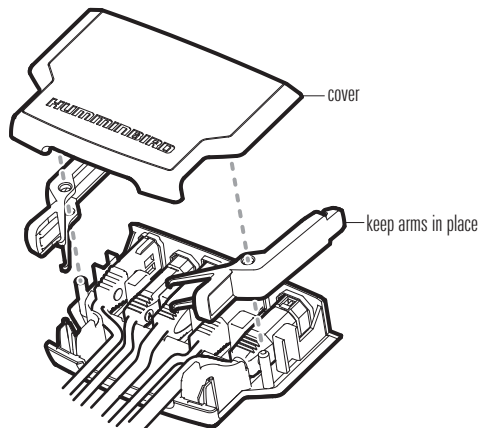

5. Install the screws in the holes on the bottom of the tray. **Hand tighten only.** See the illustration **Removing the Screws** to replace the screws. **Hand tighten only.**
6. Turn over the cable tray so the Humminbird logo is facing up. Confirm the cables hang straight, and untwist them if necessary.
7. Line up the slots on the cable tray with the matching ports on the back of the control head. Line up the cable tray pins with the holes on the control head (see the illustration **Locating the Cable Tray Slots**).

With the Humminbird logo facing up, plug the cable tray into the back of the control head. The cable tray clasps should click into place. See the illustration **Connecting the Cable Tray to the Control Head**.

Connecting the Cable Tray to the Control Head

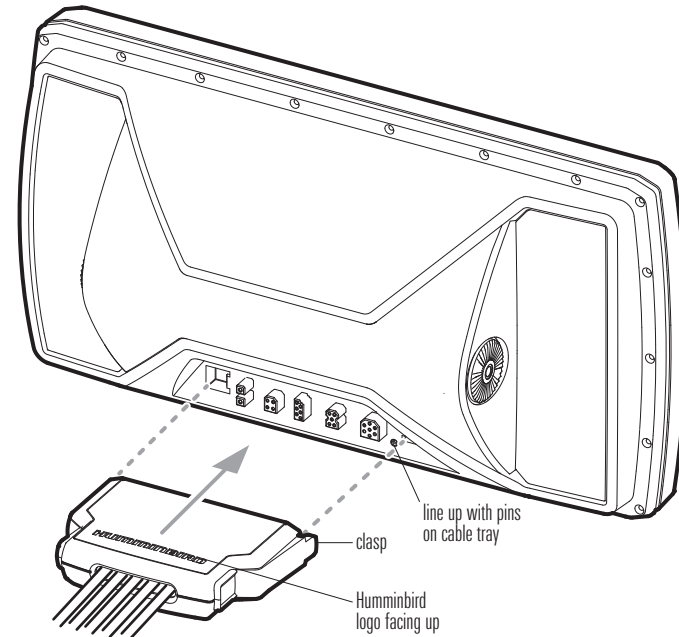

8. Pull carefully on the cable tray to confirm the installation is secure. Make sure both clasps clicked into place in step 7.

6. Secure the Control Head Installation

1. Slide the control head into the bracket.
2. Confirm there is enough cable slack to allow for the control head to pivot through its full tilt range and for connecting or disconnecting the cables.

NOTE: If there is excess cable that needs to be gathered at one location, dress the cable routed from both directions so that a single loop is left extending from the storage location. Doubling the cable up from this point, form the cable into a coil. Storing excess cable using this method can reduce electronic interference.

Storing Excess Cable

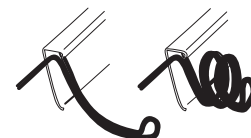

3. Adjust the control head to the viewing angle you prefer. Hand tighten the gimbal knobs until the assembly is secured. **Hand tighten only!**

Remove the Cable Tray (Optional): Squeeze the sides of the cable tray until it releases.

Removing the Cable Tray (Optional)

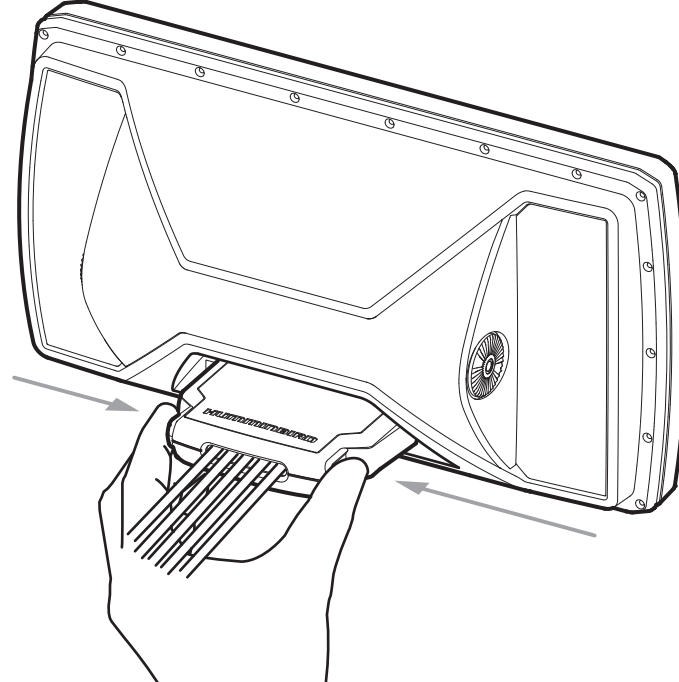

7. Test the System Installation

1. Press the POWER key to turn on the control head.
2. While the Title screen is shown on the display, press the MENU key.
3. Press the DOWN Cursor key to choose **System Status**, and press the RIGHT Cursor key to select it.

NOTE: If you wait too long, the system will automatically start whichever menu is highlighted, and you will have to start again.

4. **Accessories:** Press the VIEW key. Review the Accessory Test View to confirm accessories are listed as connected.

NOTE: The speed will be detected only if the temp/speed paddlewheel (optional) has moved since the control head has been powered on.

5. **GPS Reception:** Press the VIEW key. Review the GPS Diagnostic View and confirm that a **latitude/longitude position** is displayed and the **Fix Type** is listed as Enhanced or 3D.
6. **Power Off:** Press and hold the POWER key to power off the unit.

7. **Sonar Test:** Test and finalize the transducer installation using the instructions in the transducer installation guide. When the transducer test and installation are completed, your control head is ready for on-the-water operation. When you power on the control head, it will start Normal mode automatically if a functioning transducer is detected.

NOTE: For operations information, see the Operations Summary Guide included with your control head and the control head operations manual.

Important Notices

WARNING! This product contains chemicals known to the State of California to cause cancer and birth defects or other reproductive harm.

WARNING! Disassembly and repair of this electronic unit should only be performed by authorized service personnel. Any modification of the serial number or attempt to repair the original equipment or accessories by unauthorized individuals will void the warranty.

WARNING! This device should not be used as a navigational aid to prevent collision, grounding, boat damage, or personal injury. When the boat is moving, water depth may change too quickly to allow time for you to react. Always operate the boat at very slow speeds if you suspect shallow water or submerged objects.

FCC NOTICE: This device complies with Part 15 of the FCC Rules. Operation is subject to the following two conditions: (1) this device may not cause harmful interference, and (2) this device must accept any interference received, including interference that may cause undesired operation.

CAUTION! This equipment has been tested and found to comply with the limits for a Class B digital device, pursuant to Part 15 of the FCC Rules. These limits are designed to provide reasonable protection against harmful interference in a residential installation. This equipment generates, uses and can radiate radio frequency energy and, if not installed and used in accordance with the instructions, may cause harmful interference to radio communications. However, there is no guarantee that interference will not occur in a particular installation. If this equipment does cause harmful interference to radio or television reception, which can be determined by turning the equipment off and on, the user is encouraged to try to correct the interference by one or more of the following measures:

- Reorient or relocate the receiving antenna.
- Increase the separation between the equipment and receiver.
- Connect the equipment into an outlet on a circuit different from that to which the receiver is connected.
- Consult the dealer or an experienced radio/TV technician for help.

ENVIRONMENTAL COMPLIANCE STATEMENT: It is the intention of Johnson Outdoors Marine Electronics, Inc. to be a responsible corporate citizen, operating in compliance with known and applicable environmental regulations, and a good neighbor in the communities where we make or sell our products.

WEEE DIRECTIVE: EU Directive 2002/96/EC "Waste of Electrical and Electronic Equipment Directive (WEEE)" impacts most distributors, sellers, and manufacturers of consumer electronics in the European Union. The WEEE Directive requires the producer of consumer electronics to take responsibility for the management of waste from their products to achieve environmentally responsible disposal during the product life cycle.

WEEE compliance may not be required in your location for electrical & electronic equipment (EEE), nor may it be required for EEE designed and intended as fixed or temporary installation in transportation vehicles such as automobiles, aircraft, and boats. In some European Union member states, these vehicles are considered outside of the scope of the Directive, and EEE for those applications can be considered excluded from the WEEE Directive requirement.

This symbol (WEEE wheelee bin) on product indicates the product must not be disposed of with other household refuse. It must be disposed of and collected for recycling and recovery of waste EEE. Johnson Outdoors Marine Electronics, Inc. will mark all EEE products in accordance with the WEEE Directive. It is our goal to comply in the collection, treatment, recovery, and environmentally sound disposal of those products; however, these requirements do vary within European Union member states. For more information about where you should dispose of your waste equipment for recycling and recovery and/or your European Union member state requirements, please contact your dealer or distributor from which your product was purchased.



XNT METAL BRACKET & TRANSDUCER INSTALLATION GUIDE

Use the instructions in this guide to install the transducer on the transom of the boat.

Supplies: In addition to the hardware supplied with your transducer, you will need a powered hand drill and various drill bits, various hand tools, including a ruler or straightedge, a level, a socket driver, a 12" plumb line (weighted string or monofilament line), marker or pencil, safety glasses and dust mask, marine-grade silicone sealant, and dielectric grease (optional). You may also need extension cables and hardware for routing the cable to the control head.

NOTE: Due to the wide variety of hulls, only general instructions are presented in this installation guide. Each boat hull represents a unique set of requirements that should be evaluated prior to installation. It is important to read the instructions completely and understand the mounting guidelines before beginning installation.

NOTE: Your transducer may not look exactly like the transducer shown in the illustrations, but it will mount in exactly the same way.

NOTE: When drilling holes in fiberglass hulls, it is best to start with a smaller bit and use progressively larger drill bits to reduce the chance of chipping or flaking the outer coating.

NOTE: If the included transducer will not work for your application, you may exchange it, NEW and UNASSEMBLED, with mounting hardware included, for a transducer appropriate for your application - often at very little or no charge depending on the transducer.

Preparation

1. Install the control head before you start the transducer installation. See the control head installation guide.
2. Read the instructions in this transducer guide completely to understand the mounting guidelines before starting the installation.

Installation

There are a number of ways to install a transducer on your boat. The transom mount installation provides the least loss of signal since the transducer is mounted outside the boat hull. This installation also allows adjustment of both running angle and depth after the transducer is mounted, which enables you to tune the installation for best results.

New Installation: Proceed to section 1. *Locating the Transducer Mounting Position.*

Previously-Installed XNT Transducer: If you have a previously-installed XNT transducer on the transom, the bracket in this installation kit can be installed in the same location using the following instructions:

1. Line up the metal bracket with the previously-used mounting holes to confirm that the two slot holes match the previous installation. Fill any unused holes with marine-grade sealant.
2. Make sure the boat is level on the trailer, both from port to starboard and from bow to stern, by placing your level on the deck of the boat, first in one direction, then in the other.
3. Proceed to section 3. *Assembling the Transducer and Initial Mounting.*

1. Locating the Transducer Mounting Position

Turbulence: You must first determine the best location on the transom to install the transducer. It is very important to locate the transducer in an area that is relatively free of turbulent water. Consider the following to find the best location with the least amount of turbulence:

NOTE: Traveling over 65 mph with the transducer in the water is not recommended with the XNT 9 Si 180 T, XNT 9 DB 74 T, and XNT 14 74 T, as damage might occur. If speed above 65 mph is critical, a different mounting technique or another transducer type should be considered. See the FAQ (Frequently Asked Questions) section of our Web site at or call Customer Service.

As the boat moves through the water, turbulence is generated by the weight of the boat and the thrust of the propeller(s) - either clockwise or counterclockwise. This turbulent water is normally confined to areas immediately aft of ribs, strakes, or rows of rivets on the bottom of the boat, and in the immediate area of the propeller(s). Clockwise propellers create more turbulence on the port side. On outboard or inboard/outboard boats, it is best to locate the transducer at least 15" (38.1 cm) to the side of the propeller(s) (Figure 3).

The best way to locate turbulence-free water is to view the transom while the boat is moving. This method is recommended if maximum high-speed operation is a high priority. If this is not possible, select a location on the transom where the hull forward of this location is smooth, flat, and free of protrusions or ribs (Figure 1).

On boats with stepped hulls, it may be possible to mount the transducer on the step. Do not mount the transducer on the transom behind a step to avoid popping the transducer out of the water at higher speeds. The transducer must remain in the water for the control head to maintain the sonar signal (Figure 2).

Find a turbulence-free location at least 15" (38.1 cm) from the propeller(s) and not in line with trailer bunks or rollers.

If the transom is behind the propeller(s), it may be impossible to find an area clear from turbulence, and a different mounting technique or transducer type should be considered.

If you plan to trailer your boat, do not mount the transducer too close to trailer bunks or rollers to avoid moving or damaging the transducer during loading and unloading of the boat.

NOTE: If you require a high-speed application and cannot find a transom mount location that will work for your boat hull, a different mounting technique or transducer type should be considered. See the FAQ (Frequently Asked Questions) section of our Web site or call Customer Service.

Side Imaging®: If you have a Side Imaging transducer, it has some special requirements because of its side viewing capabilities:

The Side Imaging transducer must NOT have anything obstructing the 'view' of the side looking beams. For example, nothing can be in the line of sight of these beams (not a hull, motor, or other transducer, etc. [Figure 4]).

NOTE: You may need to tilt the motor up and out of the way when using the side looking beams.

In order for the side beams to be displayed accurately, the transducer must be mounted so that it is looking straight down in the water when the boat is in the water.

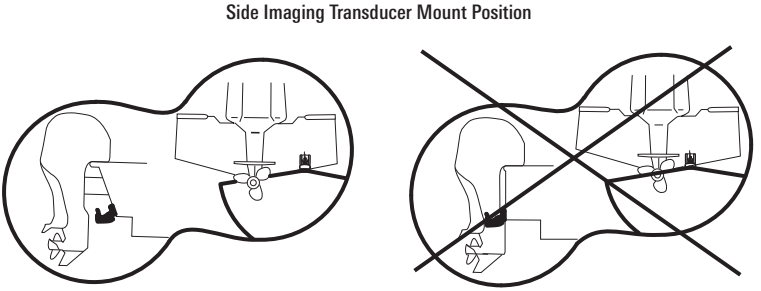

Unobstructed View: The jack plate gives the transducer safe distance from the motor and turbulence. The Side Imaging has a clear view side-to-side.

Obstructed View: The transducer is too close to motor turbulence, and the Side Imaging view is blocked by the motor. The view cannot extend from side-to-side.

NOTE: The hydrodynamic shape of your transducer allows it to point straight down without deadrise adjustment (Figure 5).

2. Preparing the Mounting Location

In this procedure, you will determine the mounting location and drill two mounting holes, using the transducer mounting bracket as a guide.

1. Make sure the boat is level on the trailer, both from port to starboard and from bow to stern, by placing your level on the deck of the boat, first in one direction, then in the other.
2. Hold the mounting bracket against the transom of the boat in the location you have selected (Figure 6). Align the bracket horizontally, using the level. Make sure that the lower corner of the bracket does not protrude past the bottom of the hull, and there is at least 1/4" (6 mm) clearance between the bottom of the bracket and the bottom of the transom for fiberglass boats, and 1/8" (3 mm) clearance for aluminum boats (Figure 7).

NOTE: If you have a flat-bottomed aluminum boat, some additional adjustment may be needed to accommodate the rivets on the bottom of the boat (the gap may need to be a little smaller than 1/8"). This will help you to avoid excessive turbulence at high speeds.

NOTE: If your propeller moves clockwise (in forward, as you're facing the stern of the boat from behind), mount the transducer on the starboard side, and align the bottom right corner of the mounting bracket with the bottom of the boat. If your propeller moves counterclockwise (in forward, as you're facing the stern of the boat from behind), mount the transducer on the port side, and align the bottom left corner of the mounting bracket with the bottom of the boat.

3. Continue to hold the bracket on the transom of the boat, and use a pencil or marker to mark where to drill the two mounting holes. Mark the drill holes near the top of each slot, making sure that your mark is centered in the slot (Figure 8).

NOTE: The third hole should not be drilled until the angle and height of the transducer is finalized, which you will not do until a later procedure.

4. Make sure that the drill bit is perpendicular to the actual surface of the transom, NOT parallel to the ground, before you drill. Using a 5/32" (4 mm) bit, drill the two holes only to a depth of approximately 1" (25.4 mm).

NOTE: When drilling holes in fiberglass hulls, it is best to start with a smaller bit and use progressively larger drill bits to reduce the chance of chipping or flaking the outer coating.

3. Assembling the Transducer and Initial Mounting

In this procedure, you will assemble the transducer using the hardware provided, then mount it and make adjustments to its position without locking it in place.

NOTE: You will initially assemble the transducer and the pivot arm by matching the two ratchets to a numbered position on the transducer knuckle. Further adjustments may be necessary.

- 1a. If you already know your transom angle, refer to the chart below for the initial position to use to set the ratchets (Figure 9). If your transom is angled at 14 degrees (a common transom angle for many boats) use position 1 for the ratchets. In either case, go to step 2.

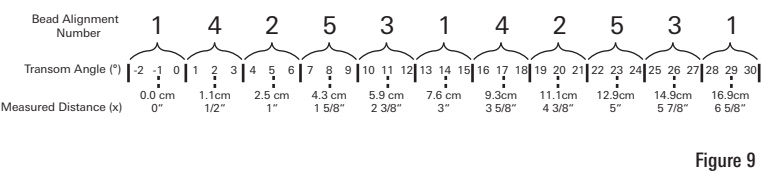

1b. If you do not know your transom angle, measure it using a plumb line (weighted nylon string or monofilament line) exactly 12 inches long. Hold the top of the plumb line against the top of the transom with your finger, and wait until the line hangs straight down (Figure 10). Using a ruler, measure the distance from the bottom of the plumb line to the back of the transom, then use the chart (Figure 9).

NOTE: It is important to take your measurement in the location shown in Figure 10, from exactly 12 inches (30.48 cm) down from the top of the transom.

2. Place the two ratchets, one on either side of the transducer knuckle, so that the beads on each ratchet line up with the desired position number on the knuckle (Figure 11a). If you are setting the ratchets at position 1, the beads on each ratchet will line up with the rib on the transducer knuckle to form one continuous line on the assembly (Figure 11b).

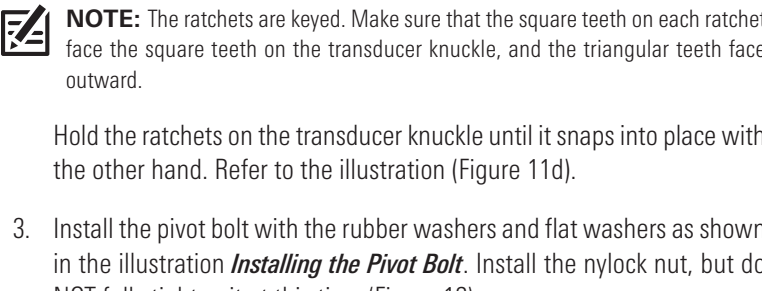
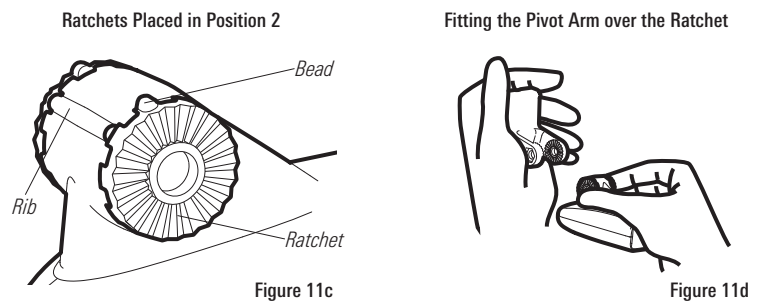
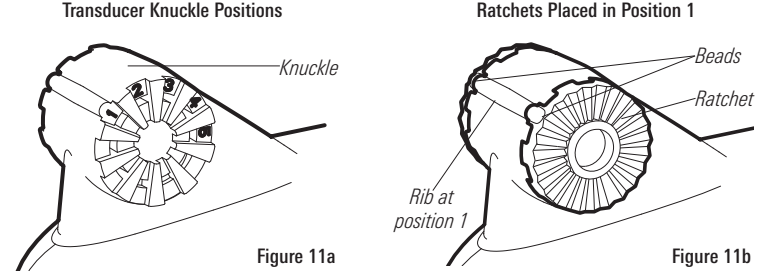

NOTE: The ratchets are keyed. Make sure that the square teeth on each ratchet face the square teeth on the transducer knuckle, and the triangular teeth face outward.

Hold the ratchets on the transducer knuckle until it snaps into place with the other hand. Refer to the illustration (Figure 11d).

3. Install the pivot bolt with the rubber washers and flat washers as shown in the illustration *Installing the Pivot Bolt*. Install the nylock nut, but do NOT fully tighten it at this time (Figure 12).

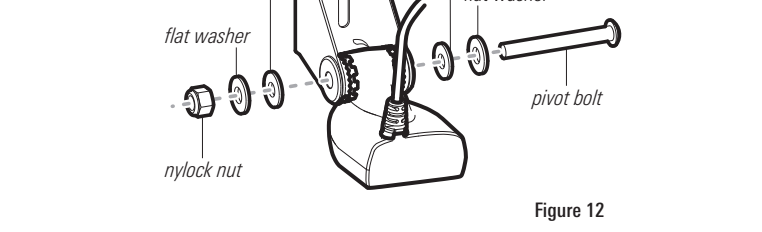
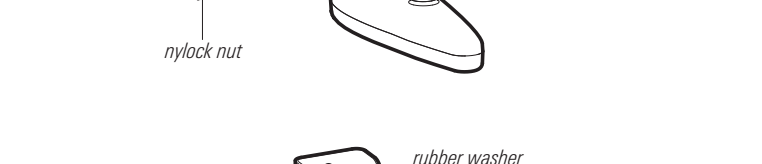
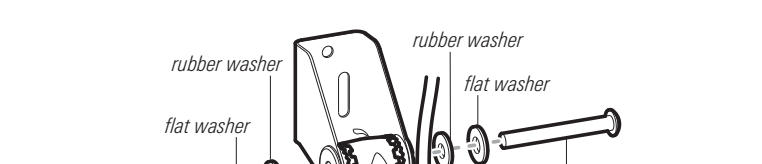
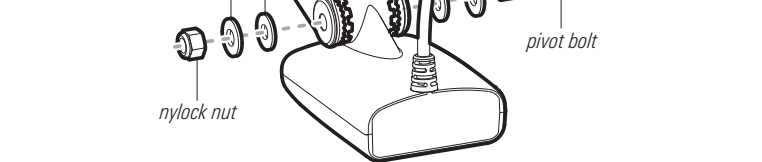

4. Align the mounting bracket transducer assembly with the drilled holes in the transom. With a 5/16" (8 mm) socket driver, mount the assembly to the transom using the two #10 - 1" (25.4 mm) long screws provided. **Hand-tighten only!**

NOTE: Make sure that the mounting screws are snug, but do not fully tighten the mounting screws at this time to allow the transducer assembly to slide for adjustment purposes.

5. Adjust the initial angle of the transducer from back to front by rotating the transducer until the side seam on the transducer is almost parallel with the bottom of the boat, one click at a time in either direction (Figure 13).

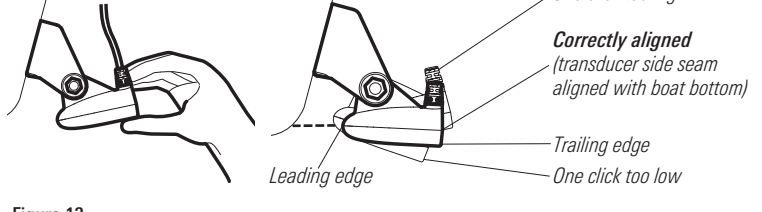
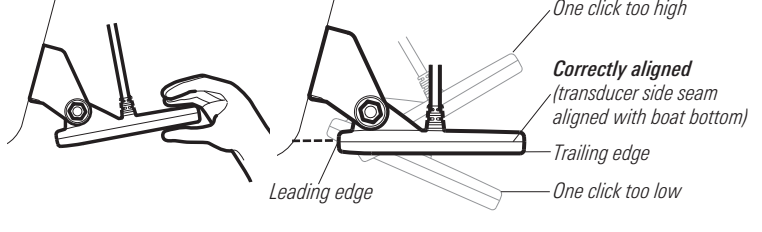
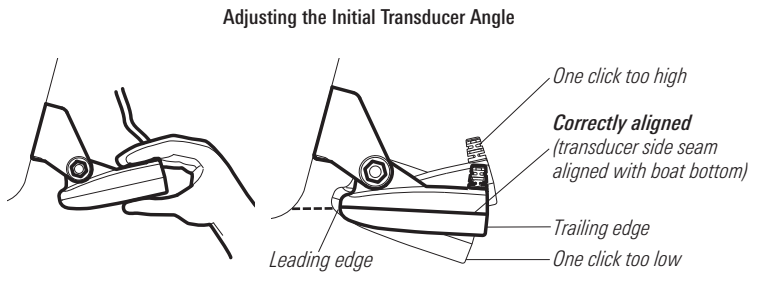

6. Adjust the transducer assembly vertically, until the seam on the leading edge of the transducer (the edge closest to the transom of the boat) is level and just slightly below the hull. (Figure 14)

Downward Slant: The transducer has a natural downward slant of 4 to 5 degrees from leading edge (closest to the boat transom) to trailing edge (farthest away from the boat). Looking at the back of the transducer, the seam should be slightly below the bottom of the hull.

Down Imaging® Transducers: A downward slant is not required for XNT 9 DI T, XNT 14 DI T. Adjust the running angle so that the transducer is parallel to the water, and submerged in the water, so that the beams point straight down during operation.

7. Continue to adjust the transducer assembly until the bracket is also level from port to starboard (horizontally level as you look at the transducer from behind the boat). (Figure 15)

8. Mark the correct position on the transom by tracing the silhouette of the transducer mounting bracket with a pencil or marker.

9. Tighten the pivot bolt, using the nylock nut to lock the assembly. **Hand tighten only!**

CAUTION! Do not use a high speed driver on this combination of fasteners. Hand tighten only.

10. Hand-tighten the two mounting screws.

NOTE: You will drill the third mounting hole and finalize the installation after you route the cable and test and finish the installation in the following procedures.

4. Routing the Cable

You can route the cable over the transom or through a hole in the transom above the waterline. Your boat may have a pre-existing wiring channel or conduit that you can use to route the cable. Select the routing method that is best for your boat configuration, and purchase any extension cables, cable clips, clamps, etc. as needed.

Also, keep in mind the following:

- It is best to route the cable to the side of the transducer so the transducer will not damage the cable during movement.
- The transducer can pivot up to 90 degrees in the bracket. Allow enough slack in the cable for this movement.
- If you drill any holes, fill them with marine-grade silicone sealant.

CAUTION! Do not cut or shorten the transducer cable, and try not to damage the cable insulation. Route the cable as far as possible from any VHF radio antenna cables or tachometer cables to reduce the possibility of interference. If the cable is too short, extension cables are available to extend the transducer cable up to a total of 50'. For assistance, contact Humminbird® Customer Service.

CAUTION! Do NOT mount the cables where the connectors could be submerged in water or flooded. If cables are installed in a splash-prone area, it may be helpful to apply dielectric grease to the inside of the connectors to prevent corrosion. Dielectric grease can be purchased separately from a general hardware or automotive store.

Excess Cable: If there is excess cable that needs to be gathered at one location, dress the cable routed from both directions so that a single loop is left extending from the storage location. Doubling the cable up from this point, form the cable into a coil. Storing excess cable using this method can reduce electronic interference (Figure 17).

5. Connecting the Cable

1. Connect the transducer cable to the transducer port on the control head. See your control head installation guide for details.

The connector is keyed to prevent reversed installation, and insertion should be easy. Do not force the connectors into the ports.

If the cable connector is round, hand tighten the screw nut to secure the cable connection. **Hand tighten only!**

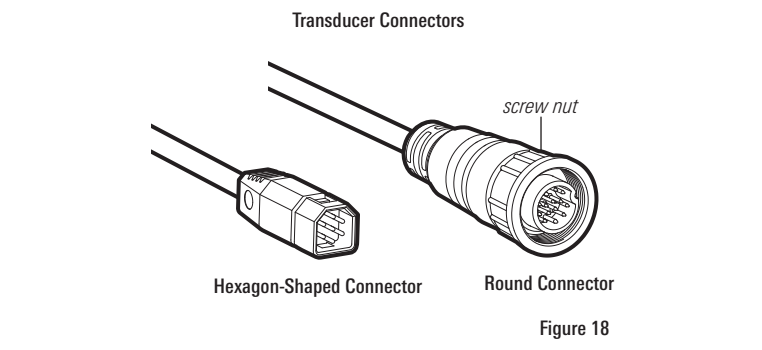

6. Testing and Finishing the Installation

Once you have installed both the control head and the transom transducer, and have routed all the cables, you must perform a final test before locking the transducer in place. Testing should be performed with the boat in water deeper than 2 feet. The transducer should be fully submerged because the sonar signal cannot pass through air.

1. Press the POWER key to turn on the control head. If the transducer is detected, the control head will start Normal mode.
2. Select a Sonar View to display on-screen. **HELIX®:** Press and hold the VIEW key. Select Sonar > Sonar View. **SOLIX™:** Press the Home key. Select a Sonar View. **Other:** See your control head operations manual.

3. If the bottom is visible on-screen with a digital depth readout, the unit is working properly.
4. If the unit is working properly, gradually increase the boat speed to test high-speed performance. If the unit functions well at low speeds, but begins to skip or miss the bottom at higher speeds, the transducer requires adjustment.

NOTE: The Down Imaging Transducer (XNT 9 DI T, XNT 14 DI T) provides the maximum detail at slower boat speeds, however high-speed performance is available in the Down Imaging and traditional 2D sonar views.

5. If you have the correct angle set on the transducer, yet lose a bottom reading at high speed, adjust the height and the running angle in small increments to give you the ideal transducer position for your boat. First, adjust the height in small increments (Figure 14).

NOTE: The deeper the transducer is in the water, the more likely that a rooster tail of spray will be generated at high speeds, so make sure that the transducer is as high as it can be and still be submerged in the water.

If you are still not getting good high speed readings, you may need to disassemble the transducer mounting assembly and re-position the ratchets (Figures 11a - 11d).

If you do change the transducer position, re-trace the position of the mounting bracket before proceeding.

NOTE: It is often necessary to make several incremental transducer adjustments before optimum high speed performance is achieved. Due to the wide variety of boat hulls, however, it is not always possible to obtain high speed depth readings.

6. Once you have reached a consistently good sonar signal at the desired speeds, you are ready to lock down the transducer settings. Re-align the mounting bracket against the transom of the boat to match the traced silhouette. Check the bracket position with the level again to make sure it is still level, then mark the third mounting hole using a pencil or marker.

7. Unscrew and remove the mounting screws and the transducer assembly and set aside.

8. Drill the third mounting hole, using a 5/32" (4 mm) drill bit. Use a marine-grade silicone sealant to fill all three drilled mounting holes, especially if the holes penetrated the transom wall.

NOTE: On fiberglass hulls, it is best to use progressively larger drill bits to reduce the chance of chipping or flaking the outer coating.

Re-position the transducer assembly against the transom of the boat, then hand-install all three screws. Make sure that the transducer location and the pivot angle have not changed, then fully tighten all three mounting screws (Figure 19). **Hand-tighten only!** If you have performed the preceding procedures correctly, the transducer should be level and at the right height for optimal operation.

7. Setting up an Accessory Transducer on the Control Head

The control head will automatically select the transducer that was included with your control head. If a compatible accessory transducer is connected to the control head, use the following instructions to set the transducer type in the control head. When you select the transducer type, the related views and menus will be added to the system. **Before you proceed, review the following information:**

- If your transducer has the round connector, the control head will automatically detect the transducer and configure it with the control head. For additional configuration information, download the Transducer Setup Guide or control head operations manual from our Web site. The instructions in this section do not apply to your fishing system.
- If your fishfinder is a PiranhaMAX™, or does not include the Transducer Select or Connected Transducer menu option, no further action is required. The transducer will be detected automatically if it is compatible with the control head. See your control head operations manual for details.

1. **Main Menu:** Press the Menu key twice.
2. Select the Sonar tab > Connected Transducer.
3. Press the RIGHT or LEFT Cursor keys to select the transducer type (Dual Beam, Side Imaging, etc.). The available menu options will depend on the installed transducer model.
4. **Close:** Press the EXIT key until the Menu System is closed. Your control head is now ready for operation.

WARNING! Disassembly and repair of this electronic unit should only be performed by authorized service personnel. Any modification of the serial number or attempt to repair the original equipment or accessories by unauthorized individuals will void the warranty.

WARNING! This product contains chemicals known to the State of California to cause cancer and birth defects or other reproductive harm.

ENVIRONMENTAL COMPLIANCE STATEMENT: It is the intention of Johnson Outdoors Marine Electronics, Inc. to be a responsible corporate citizen, operating in compliance with known and applicable environmental regulations, and a good neighbor in the communities where we make or sell our products.

WEEE DIRECTIVE: EU Directive 2002/96/EC "Waste of Electrical and Electronic Equipment Directive (WEEE)" impacts most distributors, sellers, and manufacturers of consumer electronics in the European Union. The WEEE Directive requires the producer of consumer electronics to take responsibility for the management of waste from their products to achieve environmentally responsible disposal during the product life cycle.

WEEE compliance may not be required in your location for electrical & electronic equipment (EEE), nor may it be required for EEE designed and intended as fixed or temporary installation in transportation vehicles such as automobiles, aircraft, and boats. In some European Union member states, these vehicles are considered outside of the scope of the Directive, and EEE for those applications can be considered excluded from the WEEE Directive requirement.

This symbol (WEEE wheeler bin) on product indicates the product must not be disposed of with other household refuse. It must be disposed of and collected for recycling and recovery of waste EEE. Johnson Outdoors Marine Electronics, Inc. will mark all EEE products in accordance with the WEEE Directive. It is our goal to comply in the collection, treatment, recovery, and environmentally sound disposal of those products; however, these requirements do vary within European Union member states. For more information about where you should dispose of your waste equipment for recycling and recovery and/or your European Union member state requirements, please contact your dealer or distributor from which your product was purchased.



Learn more about marine electronics and navigation on our website.