

DOWN IMAGING® TRANSDUCER INSTALLATION GUIDE

Use the instructions in this guide to install the transducer on the transom of the boat.

Supplies: In addition to the hardware supplied with your transducer, you will need a powered hand drill and various drill bits, various hand tools, including a ruler or straightedge, a level, a 12" plumb line (weighted string or monofilament line), marker or pencil, safety glasses and dust mask, marine-grade silicone sealant, and dielectric grease (optional). You may also need extension cables and hardware for routing the cable to the control head.

NOTE: Due to the wide variety of hulls, only general instructions are presented in this installation guide. Each boat hull represents a unique set of requirements that should be evaluated prior to installation. It is important to read the instructions completely and understand the mounting guidelines before beginning installation.

NOTE: When drilling holes in fiberglass hulls, it is best to start with a smaller bit and use progressively larger drill bits to reduce the chance of chipping or flaking the outer coating.

Installation Options: If you cannot find a transom mount location that will work for your high-speed application, you may consider an Inside the Hull installation.

NOTE: If the included transducer will not work for your application, you may exchange it, NEW and UNASSEMBLED, with mounting hardware included, for a transducer appropriate for your application - often at very little or no charge depending on the transducer.

Preparation

1. Install the control head before you start the transducer installation. See the control head installation guide.
2. Read the instructions in this transducer guide completely to understand the mounting guidelines before starting the installation.

1. Locating the Transducer Mounting Position

Turbulence: You must first determine the best location on the transom to install the transducer. It is very important to locate the transducer in an area that is relatively free of turbulent water. Consider the following to find the best location with the least amount of turbulence:

- As the boat moves through the water, turbulence is generated by the weight of the boat and the thrust of the propeller(s) - either clockwise or counterclockwise. This turbulent water is normally confined to areas immediately aft of ribs, strakes, or rows of rivets on the bottom of the boat, and in the immediate area of the propeller(s). Clockwise propellers create more turbulence on the port side. On outboard or inboard/outboard boats, it is best to locate the transducer at least 15" to the side of the propeller(s) (Figure 3).
- The best way to locate turbulence-free water is to view the transom while the boat is moving. This method is recommended if maximum high-speed operation is a high priority. If this is not possible, select a location on the transom where the hull forward of this location is smooth, flat, and free of protrusions or ribs (Figure 1).
- On boats with stepped hulls, it may be possible to mount the transducer on the step. Do not mount the transducer on the transom behind a step to avoid popping the transducer out of the water at higher speeds. The transducer must remain in the water for the control head to maintain the sonar signal (Figure 2).

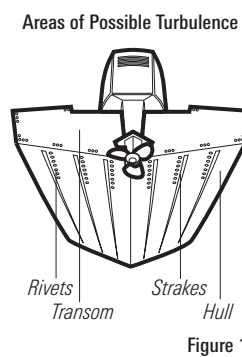

Figure 1

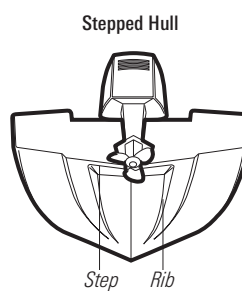
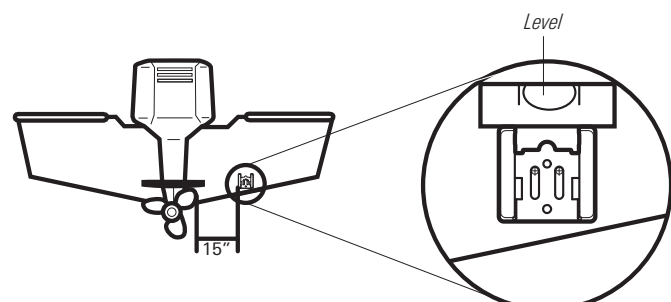

Figure 2



Find a turbulence-free location at least 15" from the propeller(s) and not in line with trailer bunks or rollers.

Figure 3

- If the transom is behind the propeller(s), it may be impossible to find an area clear from turbulence, and a different mounting technique or transducer type should be considered, such as an Inside the Hull transducer.
- If you plan to trailer your boat, do not mount the transducer too close to trailer bunks or rollers to avoid moving or damaging the transducer during loading and unloading of the boat.
- If high speed operation is critical, you may want to consider using an Inside the Hull transducer instead of this Transom Mount transducer.

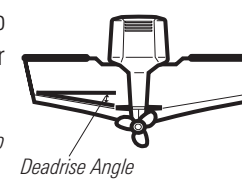

Figure 4

NOTE: The hydrodynamic shape of your transducer allows it to point straight down without deadrise adjustment (Figure 4).

2. Preparing the Mounting Location

In this procedure, you will determine the mounting location and drill two mounting holes, using the transducer mounting bracket as a guide.

1. Make sure that the boat is level on the trailer, both from port to starboard and from bow to stern, by placing your level on the deck of the boat, first in one direction, then in the other.
2. Hold the mounting bracket against the transom of the boat in the location you have selected (Figure 5). Align the bracket horizontally, using the level. Make sure that the lower corner of the bracket does not protrude past the bottom of the hull, and there is at least 1/4" clearance between the bottom of the bracket and the bottom of the transom for fiberglass boats, and 1/8" clearance for aluminum boats (Figure 6).

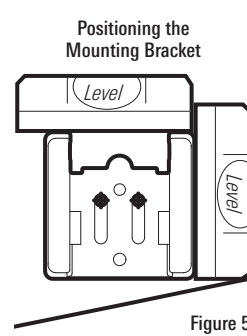

Figure 5

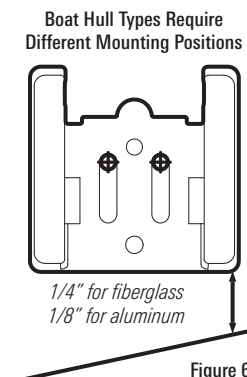

Figure 6

NOTE: If you have a flat-bottomed aluminum boat, some additional adjustment may be needed to accommodate the rivets on the bottom of the boat (the gap may need to be a little smaller than 1/8"). This will help you to avoid excessive turbulence at high speeds.

NOTE: If your propeller moves clockwise (in forward, as you're facing the stern of the boat from behind), mount the transducer on the starboard side, and align the bottom right corner of the mounting bracket with the bottom of the boat. If your propeller moves counterclockwise (in forward, as you're facing the stern of the boat from behind), mount the transducer on the port side, and align the bottom left corner of the mounting bracket with the bottom of the boat.

3. Continue to hold the bracket on the transom of the boat, and use a pencil or marker to mark where to drill the two mounting holes. Mark the drill holes near the top of each slot, making sure that your mark is centered in the slot (Figure 7).

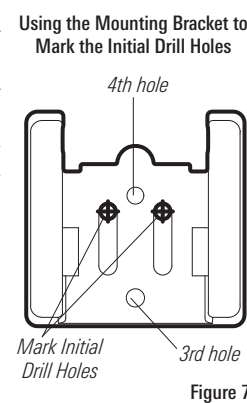

Figure 7

NOTE: The third hole should not be drilled until the angle and height of the transducer is finalized, which you will not do until a later procedure.

4. Make sure that the drill bit is perpendicular to the actual surface of the transom, NOT parallel to the ground, before you drill. Using a 5/32" bit, drill the two holes only to a depth of approximately 1".

NOTE: On fiberglass hulls, it is best to use progressively larger drill bits to reduce the chance of chipping or flaking the outer coating.

3. Assembling the Transducer and Initial Mounting

In this procedure, you will assemble the transducer using the hardware provided, then mount it and make adjustments to its position without locking it in place.

NOTE: You will initially assemble the transducer and the pivot arm by matching the two ratchets to a numbered position on the transducer knuckle. Further adjustments may be necessary.

- 1a. If you already know your transom angle, refer to the chart below for the initial position to use to set the ratchets (Figure 8). If your transom is angled at 14 degrees (a common transom angle for many boats) use position 1 for the ratchets. In either case, go to step 2.

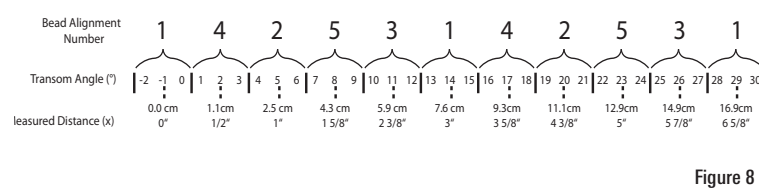

Figure 8

Or...

- 1b. If you do not know your transom angle, measure it using a plumb line (weighted nylon string or monofilament line) exactly 12 inches long. Hold the top of the plumb line against the top of the transom with your finger, and wait until the line hangs straight down (Figure 9). Using a ruler, measure the distance from the bottom of the plumb line to the back of the transom, then use the chart (Figure 8).

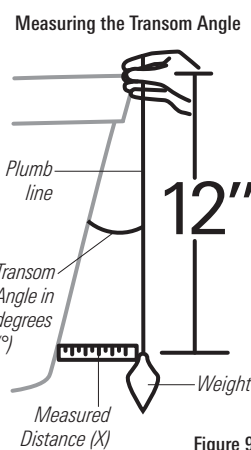

Figure 9

NOTE: It is important to take your measurement in the location shown in Figure 9, from exactly 12 inches down from the top of the transom.

2. Place the two ratchets, one on either side of the transducer knuckle, so that the beads on each ratchet line up with the desired position number on the knuckle (Figure 10a). If you are setting the ratchets at position 1, the beads on each ratchet will line up with the rib on the transducer knuckle to form one continuous line on the assembly (Figure 10b).

NOTE: The ratchets are keyed. Make sure that the square teeth on each ratchet face the square teeth on the transducer knuckle, and the triangular teeth face outward.

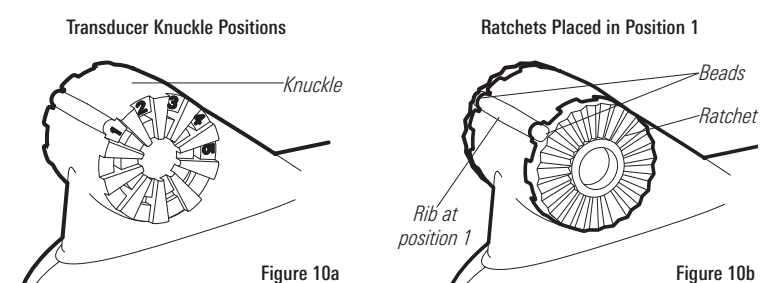

Figure 10a

Figure 10b

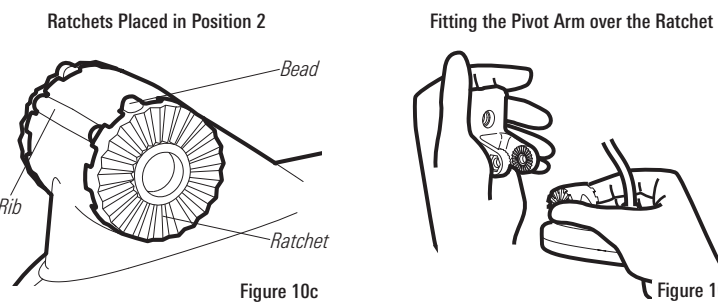

Figure 10c

Figure 10d

Hold the ratchets on the transducer knuckle with one hand and fit the pivot arm over them until it snaps into place with the other hand. Refer to the illustration (Figure 10d).

3. Put the pivot bolt through the assembly to hold it in position and loosely install the nut, but do NOT tighten the nut at this time (Figure 11).

CAUTION! Do not use a high speed driver on this combination of fasteners. Hand-tighten only.

4. Insert the pivot arm assembly into the mounting bracket (Figure 12). Do NOT snap the assembly closed, as you will need to access the mounting bracket in the next step.

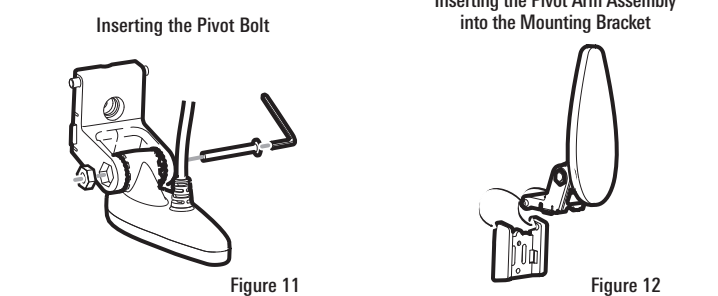

Figure 11

Figure 12

NOTE: If the pivot assembly is snapped closed over the mounting bracket, use a flat head screwdriver or similar tool to gently pry the assembly away from the mounting bracket (Figure 13).

5. Align the mounting bracket transducer assembly with the drilled holes in the transom. With a 5/16" socket driver, mount the assembly to the transom using the two #10 - 1" long screws provided (Figure 14).

NOTE: Make sure that the mounting screws are snug, but do not fully tighten the mounting screws at this time to allow the transducer assembly to slide for adjustment purposes.

6. Snap the pivot arm down into place.
7. Adjust the initial angle of the transducer from back to front by rotating the transducer until the side seam on the transducer is almost parallel with the bottom of the boat, one click at a time in either direction (Figure 15).

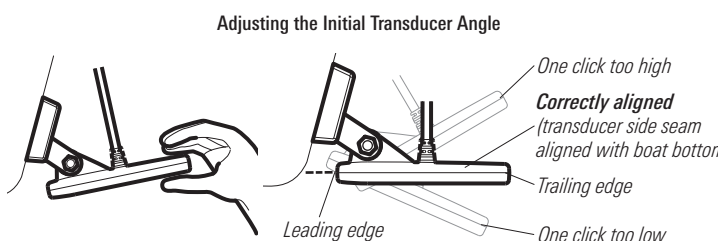

Figure 15

Figure 14

8. Adjust the transducer assembly vertically, until the seam on the leading edge of the transducer (the edge closest to the transom of the boat) is level and just slightly below the hull (Figure 16).

NOTE: A downward slant is not required for the Down Imaging transducer. Adjust the running angle so that the transducer is parallel to the water, and submerged in the water, so that the beams point straight down during operation.

9. Continue to adjust the transducer assembly until the bracket is also level from port to starboard (horizontally level as you look at the transducer from behind the boat). (Figure 17)

10. Mark the correct position on the transom by tracing the silhouette of the transducer mounting bracket with a pencil or marker.

11. Tighten the pivot bolt, using the pivot screw and nut to lock the assembly. **Hand tighten only!**

CAUTION! Do not use a high speed driver on this combination of fasteners. Hand-tighten only.

NOTE: You will drill the third mounting hole and finalize the installation after you route the cable and test and finish the installation in the following procedures.

4. Routing the Cable

You can route the cable over the transom or through a hole in the transom above the waterline. Your boat may have a pre-existing wiring channel or conduit that you can use to route the cable. Select the routing method that is best for your boat configuration, and purchase any extension cables, cable clips, clamps, etc. as needed.

Also, keep in mind the following:

- It is best to route the cable to the side of the transducer so the transducer will not damage the cable during movement.
- The transducer can pivot up to 90 degrees in the bracket. Allow enough slack in the cable for this movement.
- If you drill any holes, fill them with marine-grade silicone sealant.

CAUTION! Do not cut or shorten the transducer cable, and try not to damage the cable insulation. Route the cable as far as possible from any VHF radio antenna cables or tachometer cables to reduce the possibility of interference. If the cable is too short, extension cables are available to extend the transducer cable up to a total of 50'. For assistance, contact Humminbird Customer Service.

CAUTION! Do NOT mount the cables where the connectors could be submerged in water or flooded. If cables are installed in a splash-prone area, it may be helpful to apply dielectric grease to the inside of the connectors to prevent corrosion. Dielectric grease can be purchased separately from a general hardware or automotive store.

Excess Cable: If there is excess cable that needs to be gathered at one location, dress the cable routed from both directions so that a single loop is left extending from the storage location. Doubling the cable up from this point, form the cable into a coil. Storing excess cable using this method can reduce electronic interference (Figure 19).

5. Connecting the Cable

1. Connect the transducer cable to the transducer port on the control head. See your control head installation guide for details.

6. Testing and Finishing the Installation

Once you have installed both the control head and the transom transducer, and have routed all the cables, you must perform a final test before locking the transducer in place. Testing should be performed with the boat in water deeper than 2 feet. The transducer should be fully submerged because the sonar signal cannot pass through air.

1. Press the POWER key to turn on the control head. If the unit does not power up, check all power cable connections and that power is available.
2. When the Title screen is shown on the display, press the MENU key.
3. Press the UP Cursor key to choose Normal. Press the RIGHT Cursor key to start Normal mode.
4. Press the VIEW key repeatedly until a Sonar View is displayed on-screen. If the bottom is visible on-screen with a digital depth readout, the unit is working properly.
5. If the unit is working properly, gradually increase the boat speed to test high-speed performance. If the unit functions well at low speeds, but begins to skip or miss the bottom at higher speeds, the transducer requires adjustment.

NOTE: Down Imaging provides the maximum detail at slower boat speeds, however high-speed performance is available in the Down Imaging and traditional sonar views.

6. If you have the correct angle set on the transducer, yet lose a bottom reading at high speed, adjust the height and the running angle in small increments to give you the ideal transducer position for your boat. First, adjust the height in small increments (Figure 16).

NOTE: The deeper the transducer is in the water, the more likely that a rooster tail of spray will be generated at high speeds, so make sure that the transducer is as high as it can be and still be submerged in the water.

If you are still not getting good high speed readings, you may need to disassemble the transducer mounting assembly and re-position the ratchets (Figures 10a - 10d).

If you do change the transducer position, re-trace the position of the mounting bracket before proceeding.

NOTE: It is often necessary to make several incremental transducer adjustments before optimum high speed performance is achieved. Due to the wide variety of boat hulls, however, it is not always possible to obtain high speed depth readings.

7. Once you have reached a consistently good sonar signal at the desired speeds, you are ready to lock down the transducer settings. Force the pivot to the UP position to gain access to the mounting screws, then re-align the mounting bracket against the transom of the boat to match the traced silhouette. Check the bracket position with the level again to make sure it is still level, then mark the third mounting hole using a pencil or marker. Unscrew and remove the mounting screws and the transducer assembly and set aside.

8. Drill the third mounting hole, using a 5/32" drill bit. Use a marine-grade silicone sealant to fill all three drilled mounting holes, especially if the holes penetrated the transom wall.

NOTE: On fiberglass hulls, it is best to use progressively larger drill bits to reduce the chance of chipping or flaking the outer coating.

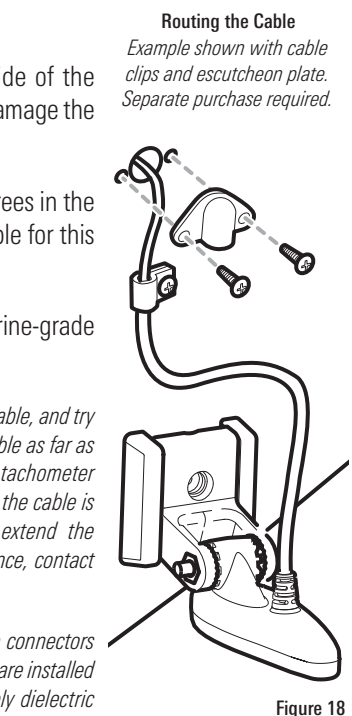

Figure 18

Figure 19

9. Re-position the transducer assembly against the transom of the boat, then hand-install all three screws. Make sure that the transducer location and the pivot angle have not changed, then fully tighten all three mounting screws (Figure 20). Snap the pivot back down. If you have performed the preceding procedures correctly, the transducer should be level and at the right height for optimal operation.

7. Locking Down the Transducer (Optional)

NOTE: You have the option to lock down the Two Piece Kick Up bracket if you do not want the transducer to kick up. Please be aware, however, that the transducer can be damaged if it is locked down and it strikes debris in the water.

1. To lock down the transducer, trace the position of the mounting bracket. Force the pivot to the UP position to gain access to the mounting screws, then re-align the mounting bracket against the transom of the boat to match the traced silhouette. Check the bracket position with the level again to make sure it is still level, then mark the fourth mounting hole using a pencil or marker (Figure 7). Unscrew and remove the mounting screws and the transducer assembly and set aside.
2. Drill the fourth mounting hole, using a 9/64" drill bit. Use a marine grade silicone sealant to fill all four drilled mounting holes, especially if the holes penetrate the transom wall.
3. Re-position the transducer assembly against the transom of the boat, then hand install the first three screws (two on the outside edge and one in the 3rd mounting hole). Make sure that the transducer location and the pivot angle have not changed, then fully tighten all three mounting screws (Figure 20). **Hand-tighten only!**
4. Snap the pivot back down. Install the #8 x 1" wood screw into the 4th hole to lock down the pivot arm (Figure 21). **Hand-tighten only!**

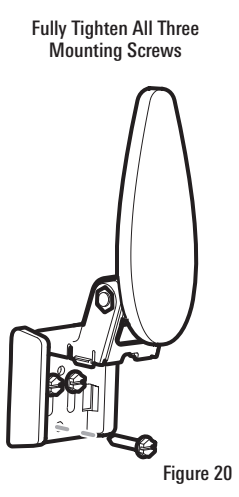

Figure 20

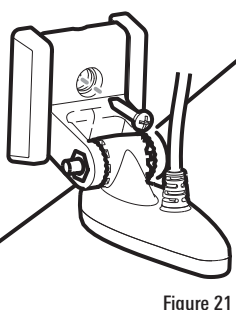

Figure 21

WARNING! Disassembly and repair of this electronic unit should only be performed by authorized service personnel. Any modification of the serial number or attempt to repair the original equipment or accessories by unauthorized individuals will void the warranty.

WARNING! This product contains chemicals known to the State of California to cause cancer and birth defects or other reproductive harm.

ENVIRONMENTAL COMPLIANCE STATEMENT: It is the intention of Johnson Outdoors Marine Electronics, Inc. to be a responsible corporate citizen, operating in compliance with known and applicable environmental regulations, and a good neighbor in the communities where we make or sell our products.

WEEE DIRECTIVE: EU Directive 2002/96/EC "Waste of Electrical and Electronic Equipment Directive (WEEE)" impacts most distributors, sellers, and manufacturers of consumer electronics in the European Union. The WEEE Directive requires the producer of consumer electronics to take responsibility for the management of waste from their products to achieve environmentally responsible disposal during the product life cycle.

WEEE compliance may not be required in your location for electrical & electronic equipment (EEE), nor may it be required for EEE designed and intended as fixed or temporary installation in transportation vehicles such as automobiles, aircraft, and boats. In some European Union member states, these vehicles are considered outside of the scope of the Directive, and EEE for those applications can be considered excluded from the WEEE Directive requirement.

