

a xylem brand

### SELF-PRIMING PUMPS

#### FEATURES

Body:	Bronze Construction
Impeller:	Nitrile Compounds
Shaft:	Stainless Steel Sleeve over Motor Shaft
Wearplate:	Replaceable
Shaft Seal:	Lip Type
Ports:	3/4" (19mm) Garden Hose External Thread and 1-1/2" NPT Internal
Motor:	1/3 HP, 115V AC 60 HZ, 1725 RPM, Single Phase, Capacitor Type, Open Drip Proof or Totally Enclosed Fan Cooled, Handle and 8' Cord with 3 prong grounded plug on ODP motor only
Weight:	20 lb (9.1 kg) with ODP Motor 25 lb (11.4 kg) with TEFC Motor

#### VARIATIONS AVAILABLE

MODEL NO.	DESCRIPTION
11810-0003	Nitrile Impeller, ODP Motor
11810-0003	Nitrile Impeller TEFC Motor

#### ⚠ WARNING



**Explosion hazard. Motor can spark. Explosion & death can occur. Do not use where flammable vapors are present.**

#### APPLICATIONS

**MARINE:** Bait tank circulation, transfer oil, wash down, and utility dock pumps.

**INDUSTRIAL:** Circulate coolant on machine tools, industrial filling systems, utility shop pump, transfer gum arabic, transfer distilled water, recharge water softeners, ice water recirculation, hydrostatic pressure testing, vacuum pump, and aspirating pump.



Model 11810-Series

**FOOD, BEVERAGE, & DAIRY:** Circulate cooling water, defrost refrigeration coils, fill drums, wash down equipment and floors, and utility pump.

**HOME:** Fill and empty tubs and pools, empty basements, cesspools, water systems, water lawns and gardens, remove water from low areas, and recharge water softeners.

**PLUMBING:** Empty clogged sumps, drains, sinks and tubs, and pump out water closets.

**FARM:** Fill tractor tires, fill water tanks, pump out silo pits, liquid manures, transfer oil, and flush and clean animal pens.

**CONTRACTORS:** Remove water from excavations, supply water to mortar boxes and cement mixing, and washdown equipment.

## OPERATING INSTRUCTIONS

- 1. INSTALLATION:** Pump may be mounted in any position without loss of efficiency; however, it is suggested that the pump head be down if vertical mounting is desired. The rotation of the motor shaft determines the location of the pump's intake and discharge ports. Refer to Dimensional Drawing. Right hand port, looking at pump end cover, is inlet port.
- 2. DRIVE:** Direct.
- 3. SELF-PRIMING:** Pump will produce a suction lift approaching 10 feet (3m) when dry and a lift up to 22 feet (6.7m) when primed. Be sure suction lines are airtight or pump will not self-prime.
- 4. RUNNING DRY:** Unit depends on liquid pumped for lubrication. Do not run dry for more than 30 seconds. Lack of liquid will damage the impeller.
- 5. PRESSURES:** For continuous operation, pressure should not exceed 20 psi (1.4 kg/sq cm).
- 6. TEMPERATURES:** Nitrile impeller recommended for liquid temperatures of 50° to 180°F (10° to 82°C).
- 7. FREEZING WEATHER:** Drain unit by loosening the end cover.
- 8. NOTICE:** Do not pump solvents, thinners, highly concentrated or organic acids. Damage to pump may result. If corrosive fluids must be handled, pump life will be prolonged if pump is flushed with water after each use or after each work day.
- 9. GASKET:** Use standard pump part. A thicker gasket will reduce priming ability. A thinner gasket will cause impeller to bind. Standard thickness 0.010".
- 10. SPARE PARTS:** A Jabsco Service Kit should be kept on hand to service all but the most badly worn 11810-Series pump.

## SERVICE INSTRUCTIONS

### DISASSEMBLY

1. Remove end cover screws, gasket and end cover.
2. Grasp impeller hub with water pump pliers and withdraw from body.
3. Loosen cam screw and remove cam. Clean off sealant. Remove wearplate with screwdriver or hooked wire.
4. Loosen nut at body clamp. Remove body from motor shaft.
5. Press put seal from motor mounting end of body towards impeller bore.
6. Remove slinger from shaft.

**NOTE:** Inspect all parts for wear or damage and replace if necessary.

## ASSEMBLY

1. Install slinger and position 1/4" from motor boss.
2. Press seal into seal bore with lip facing toward the impeller bore. Apply grease to back of seal lip.
3. Install wearplate, aligning slot with dowel pin.
4. Apply sealant to top of cam and cam screw threads. Install cam with cam screw.
5. Install body on motor. Tighten nut at clamp. Do not over tighten or binding of shaft will result.
6. Lubricate impeller bore with water pump grease.
7. Lubricate shaft OD with grease, align drive ding in extended impeller insert with flat on shaft and install impeller.
8. Install gasket, end cover and end cover screws.

### TO EQUIP WITH VACUUM SWITCH (4732-0000)

1. Install switch in tapped hole on top of inlet port. (Seal threads prior to assembly.)
2. Connect switch to motor. See diagram.
3. Plug into 115V AC outlet and hold down restart lever on switch until the pump primes.

### SPECIAL ATTENTION

1. Constant vibration of the restart lever indicates:
  - (A) An air leak. This will usually show up when the pump is first started. All suction lines should be checked for loose connections.
  - (B) A worn impeller. Impeller should be replaced.
2. Intermittent stopping and starting indicates that the unit is operating against excessive discharge pressure.

### VACUUM SWITCH WIRING DIAGRAM

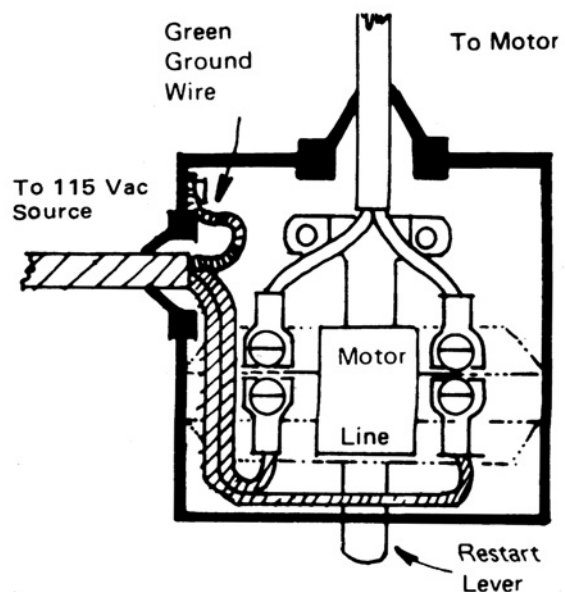

EXPLODED VIEW

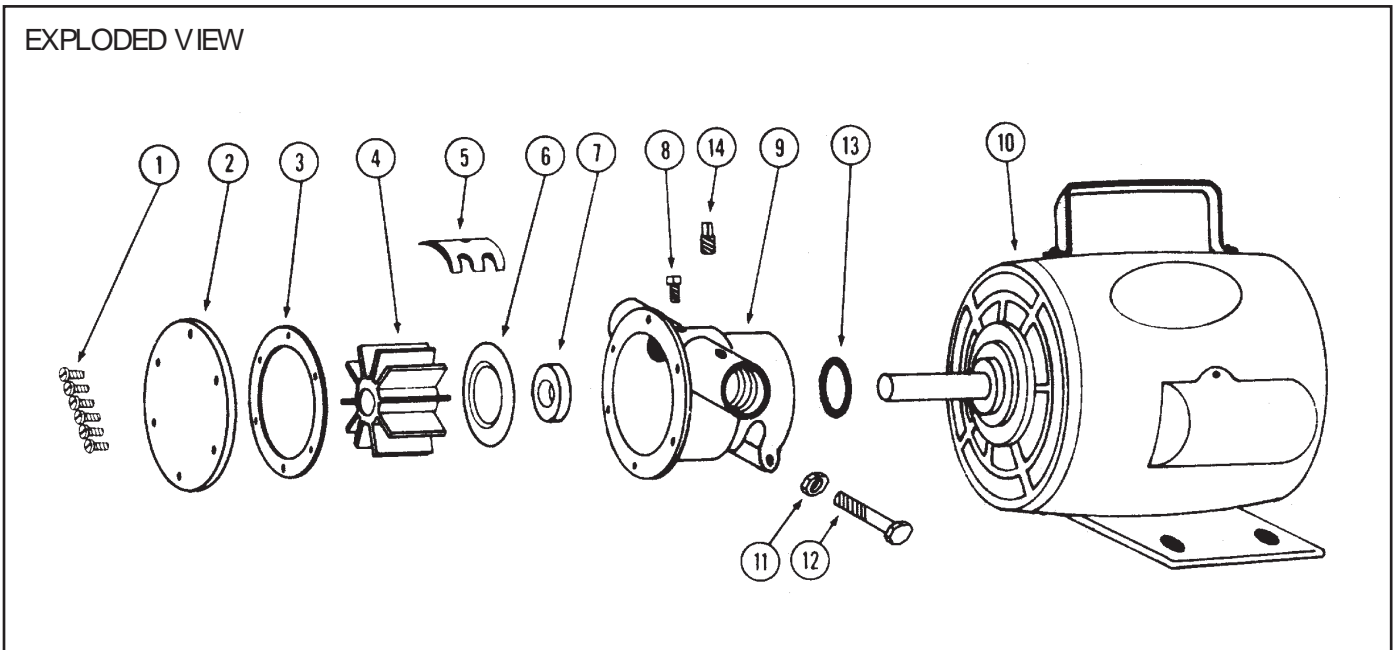

PARTS LIST

Key	Description	Qty.	6590-Series Part No.
1	Screw (End Cover)	6	91002-0020
2	End Cover	1	11830-0000
3	*Gasket	1	3298-0000
4	*Neoprene Impeller	1	5929-0001
	Nitrile Impeller		5929-0003
5	Cam	1	490-0001
6	Wearplate	1	2235-0000
7	*Seal (Shaft)	1	92700-0420
8	Screw (Cam)	1	91003-0010
9	Body	1	11814-0000
10	Motor (ODP)	1	18739-0000
	Motor (TEFC)		18753-0014
11	Nut	1	9110-0030
12	Bolt	1	91095-0090
13	Slinger (O-Ring)	1	92000-0230
14	Plug (for vacuum switch hole)	1	92650-0070

4732-0000 - Vacuum Switch Kit: Automatic shut off for use when pump is left unattended.

\* Parts contained in Service Kit.

SERVICE KITS

Pump Model Number	Service Kit Number
11810-0001	90105-0001
11810-0011	Neoprene Impeller
11810-0003	90105-0003
11810-0013	Nitrile Impeller

Kits consist of: Impeller, seal and gasket.

REPLACEMENT PUMP HEADS COMPLETE

Pump Model Number	Pump Head Number
11810-0003	11818-0003
11810-0013	Neoprene Impeller

**DIMENSIONAL DRAWING**

Inches (Millimeters)

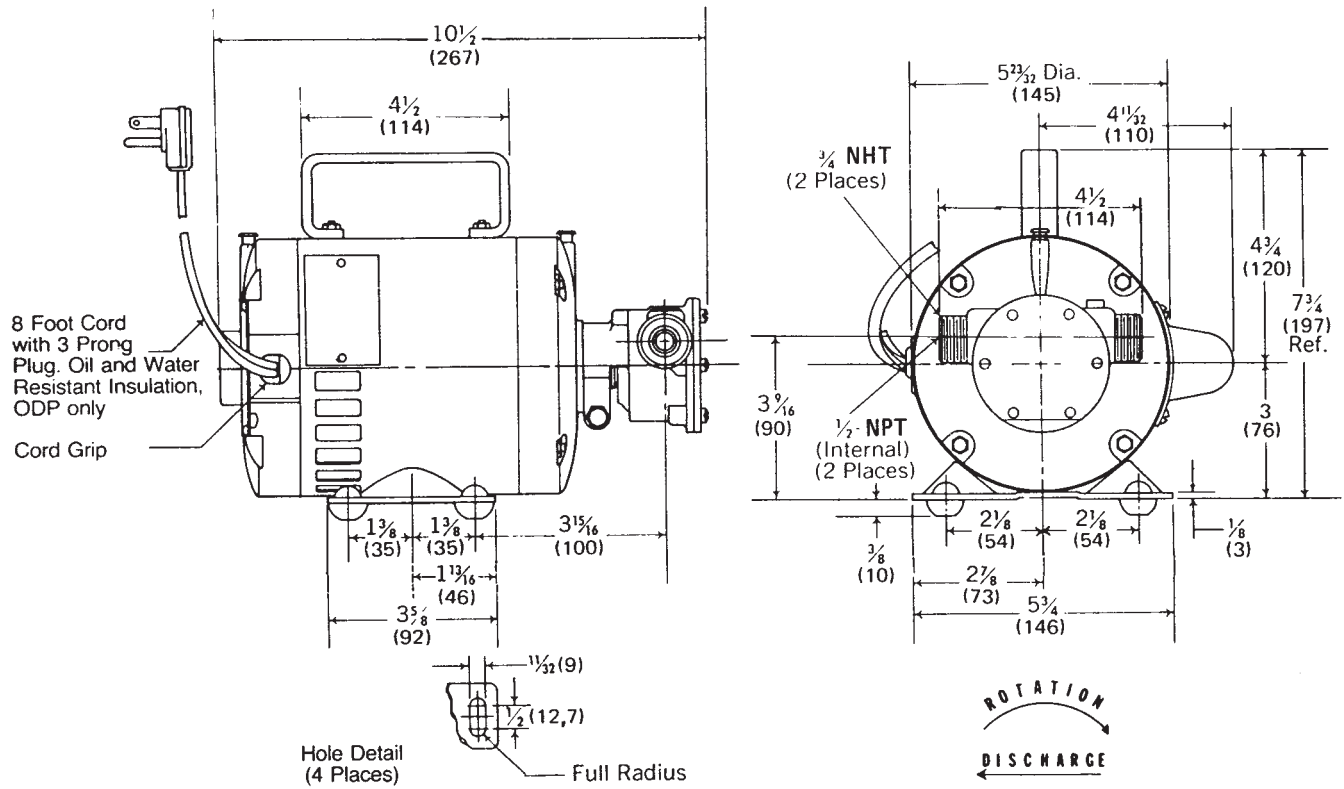

**HEAD CAPACITY TABLE**

psi	kg/sq cm	Total Head		Capacity	
		Feet	Meters	GPM	LPM
4.3	0.3	10	3	9.6	36.3
8.7	0.6	20	6	8.1	30.7
13.0	0.9	30	9	6.8	25.7
17.3	1.2	40	12	4.4	16.7

NOTE: Tables show approximate performance for new pump with nitrile impeller pumping water.

Warranty: All products of the company are sold and all services of the company are offered subject to the company's warranty and terms and conditions of sale, copies of which will be furnished upon request. The information provided herein is for guidance only, it does not constitute a guarantee of the performance or specification of any individual product or component.



a xylem brand