

a xylem brand

**PUMP****FEATURES**

<b>Body:</b>	Bronze
<b>Impeller:</b>	Nitrile
<b>Seal:</b>	Buna Lip Type
<b>Motor:</b>	Reversible Permanent Magnet With Integral Reversing Switch; Complies with USCG 183.410 and ISO 8846 Marine
<b>Valves:</b>	1/2" NPT Full Flow Ball Type
<b>Height:</b>	6-1/4" (15.9 cm) Including the height of the 1-1/8" (30 cm) tall Switch Guards
<b>Length:</b>	10-7/8" (27.6 cm)
<b>Width:</b>	10-3/16" (26.0 cm)
<b>Weight:</b>	9 lbs. (4.1 kg)

**APPLICATION**

The Jabsco Oil Change System is designed to be installed in a vessel's engine room with its manifold and valves permanently plumbed to the vessel's engines' oil pans or transmissions' oil sumps. The manifold is factory fitted with three ball valves to serve three different oil reservoirs and may be fitted with two additional ball valves to drain up to five oil reservoirs. The system can be used to remove old oil from an engine or transmission then reversed, with the integral reversing switch, to pump a measured amount of new oil back into the engine or transmission. Each connection to an engine is controlled by a dedicated full flow ball valve. The system's cover provides an attractive appearance, fully shrouding the entire pump and manifold system. It also provides added protection against accidental draining of an engine's oil supply because the valve cover protects the factory supplied valves from being accidentally bumped open. Additionally, at the end of an oil change, the cover will not close unless the factory supplied valves are in the fully closed position.

**WARNING**

**Burn Hazard. Heated oil can cause burns. Wear protective gloves, clothing and safety glasses during the oil change process. Failure to do so may result in personal injury.**

**OPERATION**

Before proceeding with an oil change, ensure the waste oil discharge hose is connected to the pump discharge port and an adequate number of empty waste oil containers are conveniently available. Run engines to be

**Model 17820 Series****Models Available**

17820-0012 12 Volts CE  
17820-0024 24 Volts CE

changed 3-5 minutes to raise the oil temperature to about 100° - 140° F (38° - 60° C) and reduce its viscosity. To change oil, simply select the valve for the sump that is intended to be changed and open it by rotating it a full 90° counterclockwise. Ensure the waste oil discharge hose is securely positioned in a waste oil receptacle (be aware that during the pumping process the discharge hose may tend to move slightly) and switch the pump on by moving the toggle switch in the direction that the oil needs to flow. Once the pumping process is complete (flow has stopped), switch the pump off immediately. Do not allow the pump to run dry for more than about thirty seconds or impeller damage may occur. Using the engine's dipstick; verify that it is in fact empty and the oil flow was not stopped by sludge. If the engine oil is empty, a measured amount of the correct type (per the engine manufacturer's recommendation) of new oil can be pumped back into the engine. Insert what was the discharge hose, and for refilling purposes becomes the intake suction hose, into a container with the measured amount of oil. Move the pump's toggle switch in the direction of desired flow toward the engine and pump the measured amount of oil into it. When the container is empty immediately turn off the pump. Close the valve for the engine that was just changed and always check the oil level with the engine's dipstick to ensure the oil level is correct.

Transmission oil sumps can be changed in the same manner but it is recommended that the oil level dipstick be removed and remain out of its socket during the pumping process. This will maximize ventilation to the transmission and ensure excessive vacuums are not

created during the oil changing process.

## INSTALLATION

The Oil Change pump and manifold assembly may be oriented in any position. However, if mounted to a vertical surface, it should not be oriented with the pump's motor below the pump head. This will ensure that, should the seal ever develop a leak, oil from the pump head will not drip onto the motor. The Oil Changer should be located where the lengths of hose can be kept as short and straight as possible. The pump is self-priming and may be positioned up to three feet above the oil source. However, for best operation the pump and manifold should be mounted at a level that is just slightly above the highest oil level to be changed. Often this is approximately even with the level of the engine mounts. Secure the pump and manifold platform to a solid mounting surface at the four corner attachment points. It is recommended that heavy duty reinforced type A fuel hose be used to connect the manifold valves with the engine pans and transmission sumps. All hose assemblies should be made with permanent type end connector fittings similar to hose assemblies for on-board natural or propane gas systems.

If additional valves are needed, to plumb the system to a maximum of five oil reservoirs, they can be added by removing the pipe plug(s) in either end of the manifold and attaching additional valves at these locations. If it is desirable to orient the additional valves in the same orientation as the three factory supplied valves, to ensure maximum performance, it is recommended that a Close Nipple and standard 90° Elbow be fitted to the manifold rather than a Street Elbow. The I.D. of a standard Elbow and Close Nipple is larger and less restrictive than a 90° Street Elbow. Apply a couple wraps of sealing tape to each pipe joint when installing additional valves.

When the system is plumbed to all oil reservoirs, each valve can be identified with its respective connection point utilizing the assorted labels provided. Select the label(s) that best identifies the device to which each valve is plumbed then peel it off the sheet of labels and apply it to the top of the system cover over the valve.

## WIRING

Connect the unit to an overload protected electrical distribution panel (circuit breaker or fuse panel) with marine grade copper stranded wire, sized to match the recommendation in the Electrical Specifications chart. The electrical circuit breaker (or fuse) must also be sized to match the Electrical Specifications recommendation. The positive and negative wire connections should be secured in place on the electrical terminal block located near the end of the valve manifold. The positive (Pos.) and negative (Neg.) terminals of the terminal block are clearly identified. Once the wiring is completed, the electrical wires should be secured to a solid surface every

eighteen inches along the length of their run to prevent movement and abrasion.

## WIRE SIZE (AWG [mm<sup>2</sup>]) for various conductor lengths

Model Number	Volts	Amp Draw	Fuse/ Brkr.	Length of run in feet (meters)*			
				0-10(0-3)	10-20(3-6)	20-30(6-9)	30-50(9-15)
17820-0012	12	10	15	16[1.5]	14[2.5]	12[4]	10[6]
17820-0024	24	5	8	16[1.5]	16[1.5]	16[1.5]	16[1.5]

\* The length of run is the total length of both positive and negative conductors measured from the positive power source to the pump and back to negative.

## SERVICE

The Jabsco Oil Change System should provide many years of reliable service without the need for regular or scheduled maintenance. However, if sludge should become lodged anywhere in the system, it can cause excessive vacuum or pressure on the pump that may damage the flexible impeller. If this occurs pump performance will be reduced and it will become necessary to change the pump's impeller.

Before performing any service work, ensure all the system valves are closed and the power to the pump is turned off and labeled "Do Not Turn On" to guard against it being accidentally turned back on while service work is being performed.

## IMPELLER REPLACEMENT

To change the impeller, the system's cover assembly must be removed. To do this, remove the cover to base attachment fasteners (one on each of three sides of the fixed cover and two under the hinged cover over the manifold) and lift the cover assembly from the base. Remove the pump end cover screws, end cover and gasket. Grasp the impeller's hub with a pair of pliers and pull the old impeller from the impeller bore. Ensure the old gasket material is cleaned from the pump body surface and the end cover.

With a rotary motion (to flex the blades of the new impeller under the cam silhouette in the pump body) push the new impeller into the body until the flat of the impeller insert aligns with the flat of the shaft. When the two flats align, push the impeller firmly into the impeller bore until it bottoms in the bore. Align a new gasket with the profile of the pump body and position the end cover against it and the body. Secure both with the end cover screws. Position the system cover over the pump and manifold and secure it to the base at its five attachment points.

## SEAL REPLACEMENT

Under normal circumstances, the shaft seal should function properly for several hundred hours of operation. If the seal should ever develop a leak and need to be replaced, begin the procedure by following the above instructions for changing an impeller. Once the impeller has been removed, remove the two screws that secure

## EXPLODED VIEW

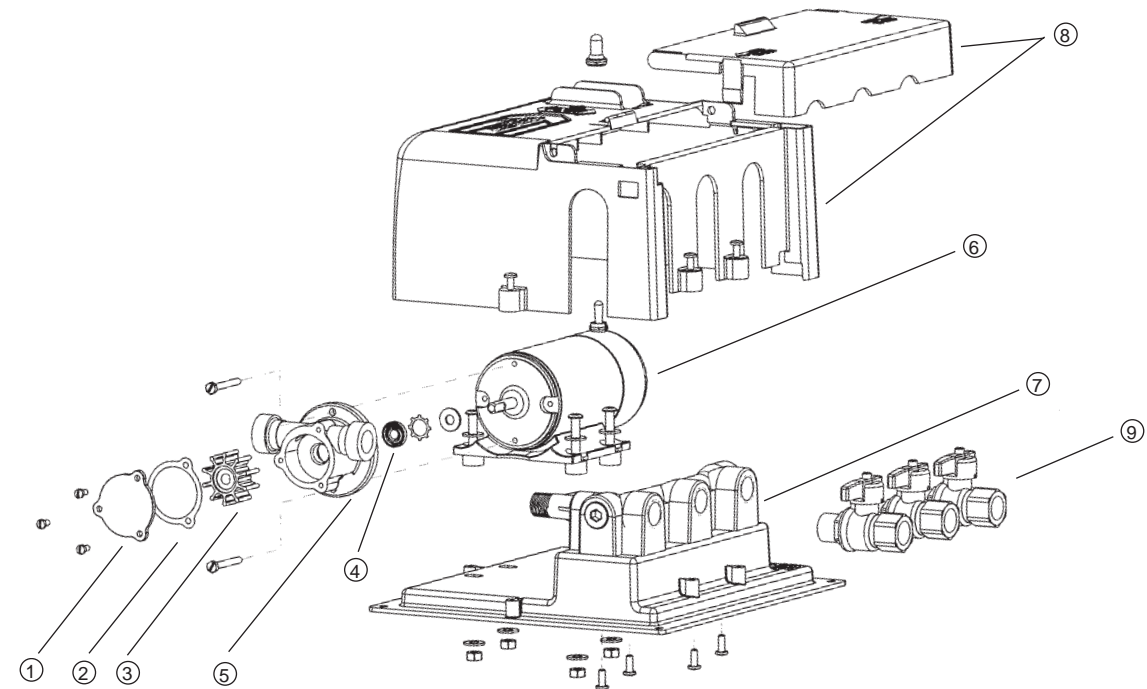

the pump head to the motor. Detach the Oil Change System from the surface it is mounted to, so the base can be raised high enough to access the nuts on the underside of it that secure the motor to the base and remove the motor attachment fasteners. When the motor is detached from the base, slide the motor straight back and away from the pump housing. With the pump housing still attached to the molded manifold nipple, support the back side of the pump housing with one hand (keeping it clear of the immediate seal area) and insert a dowel into the impeller end of the pump housing and against the lip side of the seal. With a firm push, the seal should be able to be pushed out of the seal bore toward the motor side of the pump housing. If the seal cannot be easily pushed out of the pump housing, it may be necessary to unscrew the pump housing from the molded nipple of the manifold and remove it to a work bench surface where it can be better supported as the seal is pressed from it. When the seal is removed, ensure the seal bore is clean of all debris. From the back side of the pump housing, place the new seal in the seal bore, ensuring the lip of the seal is pointing toward the impeller bore. If the pump housing is attached to the manifold's molded nipple, support the pump housing with one hand, while pressing the seal into the seal bore until it is firmly seated in the bottom of it. If the pump housing was removed from the manifold, press the seal into the seal bore, wrap the manifold's nipple with some sealing tape and reattach the pump housing to the manifold. Guide the motor shaft through the lip seal and slide it forward until the

## PARTS LIST

Key	Description	Part No.
1	*Screw Kit (4 screws) End Cover	18647-1000
2	*Gasket O-Ring	9156-0000
3	*Impeller *Seal	9200-0023
4	Slinger Screw Kit (3 screws)	18753-4364
5	Body (Complete Pump Head Only)	9130-1003
6	Motor 12 Volt, EMC 24 Volt, EMC Switch Polarity Reversing	18753-0067 18753-6636
7	Manifold/Base Cover Large Fixed	17822-9000
8	Cover Small Hinged Labels	17824-1100

\*Parts included with Service Kit : 90061-0053

## REPLACEMENT PART KITS

JABSCO RECOMMENDS THAT ALL COMPONENTS IN EACH INDIVIDUAL KIT BE REPLACED AS A MATTER OF GENERAL MAINTENANCE.

motor end bell is properly seated into the counter-bore on the back side of the pump housing. Ensure the motor remains firmly seated against the pump housing while securing it to the Oil Change System base. With this complete, the base can be re-secured to its mounting

# SECTIONAL DRAWING

