

FLANGEMOUNT 3" BLOWER

FEATURES

- Tough Reinforced Plastic Housing
- Mount To Any Surface
- Slip-On Inlet Ducting Connection
- Efficient High Volume Airflow
- Low Current Draw
- Corrosion-Resistant Materials Throughout
- N.M.M.A. Type Accepted
- Meets Regulation 183.410 and ISO 8846 MARINE for Ignition Protection
- ISO 9097 MARINE
- **CE**

SPECIFICATIONS

Open Airflow:	105 CFM (2.9m ³ /min.)
Voltage:	12V DC
Amperage:	4.4 Amps
Fuse Size:	6 Amps
Weight:	4 lb (2.3 kg)

Jabsco blowers are primarily intended for intermittent duty cycles such as evacuating fuel vapors from bilge areas. If desired, they also may be used for other general air circulation applications with longer duty cycles. However, when doing so, it should be noted that the maximum motor life is approximately 1000 hours. Therefore, the blower should only be used for applications if this length of service is acceptable.

INSTALLATION

INSTALLATIONS MUST MEET APPLICABLE SECTIONS OF TITLE 33, PART 183; SUBPART K, USCG VENTILATION REGULATIONS.

MOUNTING: Mount blower on flat bulkhead surface in highest part of compartment free from spray or deck wash. If mounting blower in a location where spray into discharge port may occur, mount blower with motor in a vertical orientation as shown in installation drawing. Cut a 2-3/4" hole in bulkhead and secure blower with washers and No. 10 screws. (**NOTICE:** Tighten screws evenly to avoid flange damage.) Use outlet collar No.34856-0000 to connect ducting to discharge vent. Use a suitable discharge fitting so that static pressure of blower will not be affected by change in wind direction. Route inlet ducting with as few bends as possible to lower 1/3 of the bilge compartment where vapors are likely to accumulate. Be sure ducting is positioned below top of engine stringers but not so low as to become submerged in bilge water. Locate pickup to take advantage of natural air flow direction. Jabsco flexible ducting No. 34959-0100 is easy to cut and install.

NOTICE: Blower should be mounted away from extreme heat (more than 130° F) to prevent distortion of blower wheel or housing.



Model 35115-0020

Jabsco ventilator intake screen No. 34764-0000 provides a safe and attractive protected inlet.

NOTE: This blower may also be mounted with inlet through bulkhead, using intake collar No. 34943-0000.

WIRING: Use stranded copper wire. For lengths up to 25 feet (7.6m) from power source: Use 16 gauge wire for runs up to 25 feet and 14 gauge for runs of 25 to 40 feet. Use larger wire for longer lengths. Use a 10 amp rated on-off switch in positive side of circuit (Jabsco Model 44960-0002 or 44960-0003). Circuit must be protected with a fuse. Suggested fuse sizes are listed in the specification table.

	<p>WARNING Explosion hazard. Gasoline vapors can explode. Before starting engine, operate blower for 4 minutes and check engine compartment bilge for gasoline vapors. Run blower below cruising speed. Failure to do so can result in injury or death.</p>
--	--

Operation: See following warning placard statement.

THE "WARNING" PLACARD (OR EQUIVALENT) SUPPLIED WITH BLOWER MUST BE MOUNTED ADJACENT TO ENGINE IGNITION SWITCHES (ALL LOCATIONS) TO COMPLY WITH TITLE 33, PART 183; SUBPART K, USCG VENTILATION REGULATIONS.

Additional warning placards are available from factory by requesting form 43003-0418.

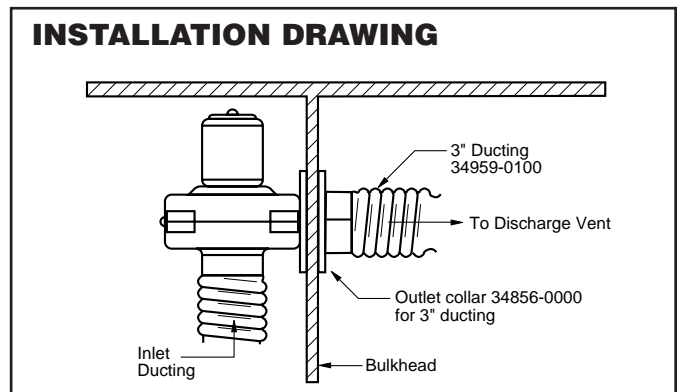

PARTS LIST

Key	Description	Qty.	Part Number
1	Motor Kit 12V DC	1	35145-0010 *
2	Blower Housing	1	35678-0000
3	Blower Wheel	1	34742-0001
4	Blower Housing	1	35679-0000
5	Screw 8 x 5/8 SS Self Tapping Pan Head	4	35508-0000

* Motor nuts not included. Order (2) 34681-0000 nut.

PARTS VIEW

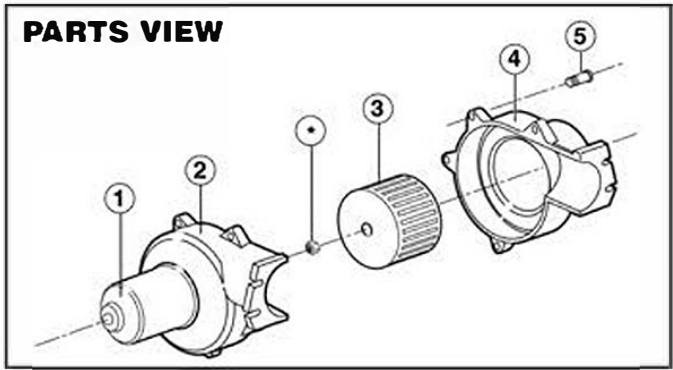

DIMENSIONAL DRAWING

Inches (Millimeters)

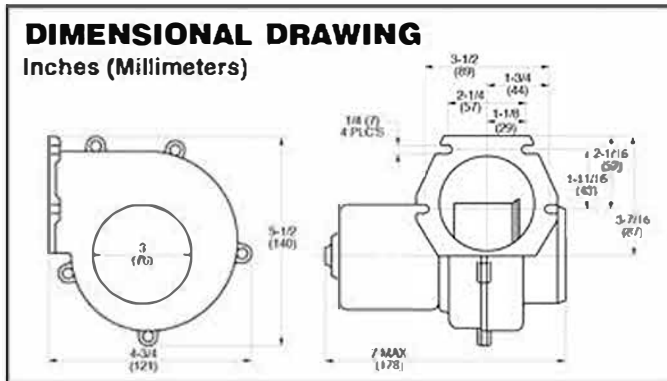

MARINE SWITCH PANELS

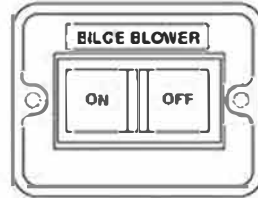

44960-0002
Lighted switch with boot SPST

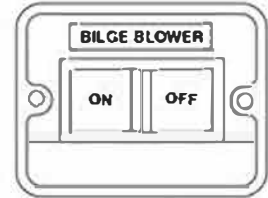

44960-0003
Unlighted SPST

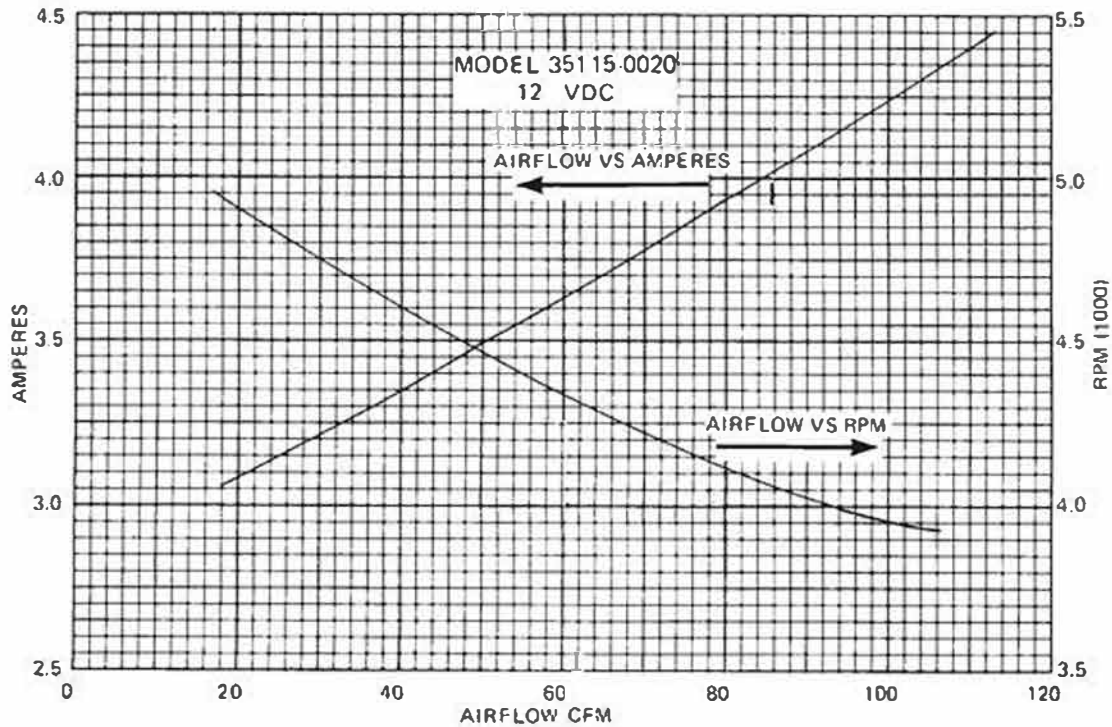

Jabsco

THE PRODUCT DESCRIBED HEREIN IS SUBJECT TO THE JABSCO ONE YEAR LIMITED WARRANTY, WHICH IS AVAILABLE FOR YOUR INSPECTION UPON REQUEST.