

The NEMP Series magnetically coupled centrifugal pumps

The highest standard in magnetically coupled centrifugal pumps.

The Flojet NEMP Series are the highest standard in magnetically coupled centrifugal pumps, driven by 110 volt induction motors. The NEMP pump family is ideal for applications involving chemicals or pure liquids and for applications where temperature fluctuation of the media must be avoided.

Pump Features and Benefits

- ✓ Spindles housings designed for higher system pressures
- ✓ High purity ceramic spindles provide wider range of chemical resistance
- ✓ Design allows for continuous duty
- ✓ PPS spindle housing designed to withstand higher temperatures
- ✓ Up to 60.7ft head and 13.7 GPM open flow
- ✓ Graphite-filled PTFE bushings allows for maximum efficiency on large NEMPs

Features

- Flow from 4.6 GPM to 13.7 GPM
- Magnetically coupled, seal-less leak free design
- Front and top port configurations
- 110 Volt AC

Wetted Materials

- Standard EPDM 'O' ring
- Strontium ferrite magnet
- Ceramic spindle
- Polypropylene and PPS housing

Motors

- 110 Volt 60 Hz induction motor
- Rated for continuous duty

Model	Port Size	Port Connection	Voltage	Part Number	Description
NEMP20/12	3/4"	Hose	110/60Hz	426992	NEMP20/12 110/60Hz PPS 3/4" HOSE EPDM
NEMP20/12	3/8"	NPT	110/60Hz	426970	NEMP20/12 110/60Hz PPS 3/8" NPT EPDM
NEMP20/18	3/4"	Hose	110/60Hz	426994	NEMP20/18 110/60Hz PPS 3/4" HOSE EPDM
NEMP20/18	3/8"	NPT	110/60Hz	426971	NEMP20/18 110/60Hz PPS 3/8" NPT EPDM
NEMP25/5	3/4"	Hose	110/60Hz	426996	NEMP25/5 110/60Hz PP 3/4" HOSE EPDM
NEMP25/5	3/8"	NPT	110/60Hz	426972	NEMP25/5 110/60Hz PP 3/8" NPT EPDM
NEMP40/6	3/4"	Hose	110/60Hz	426998	NEMP40/6 110/60Hz PP 3/4" HOSE EPDM
NEMP40/6	3/8"	NPT	110/60Hz	426974	NEMP40/6 110/60Hz PP 3/8" NPT EPDM
NEMP50/7	1"	Hose	110/60Hz	426999	NEMP50/7 110/60Hz PP 1" HOSE EPDM
NEMP50/7	1/2"	NPT	110/60Hz	426975	NEMP50/7 110/60Hz PP 1/2" NPT EPDM

xylem
Let's Solve Water



NEMP Series

MAGNETICALLY COUPLED CENTRIFUGAL PUMPS

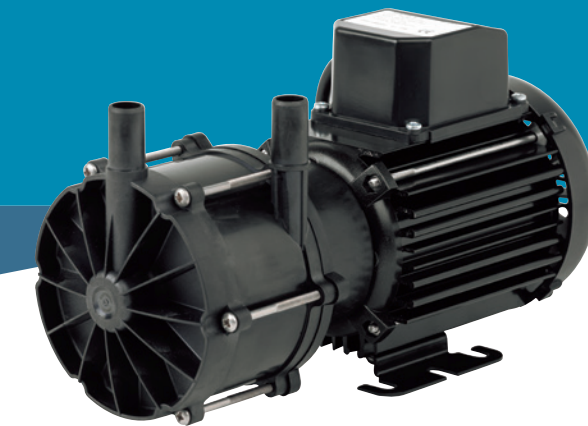

FLOJET
a xylem brand

NEMP 20/12



Specifications

Pump Design	Magnetically Coupled Centrifugal Pump
Open Flow	4.6 GPM (17.4 LPM)
Max Head	41.7ft (12.7m)
Motor Output	60 watts
Amp Draw	0.95
Max Specific Gravity*	1.2
Temperature Range	-4°F to 185°F (-20°C to 85°C)
Weight	6.6lbs (3.0kg)

*Assuming maximum viscosity of 30cp.

Dimensional Drawings

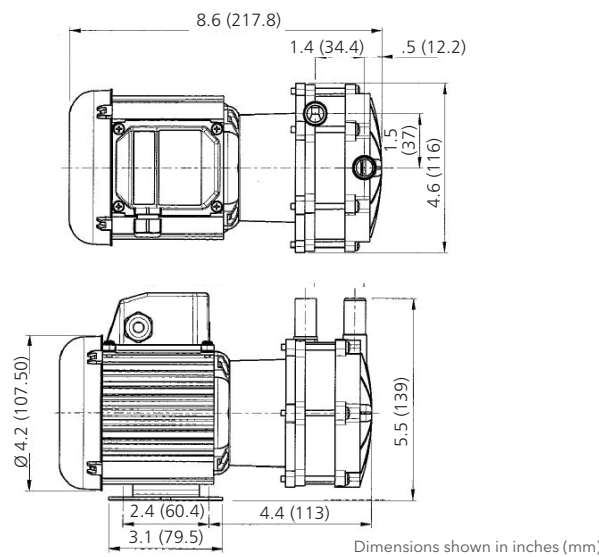

Performance

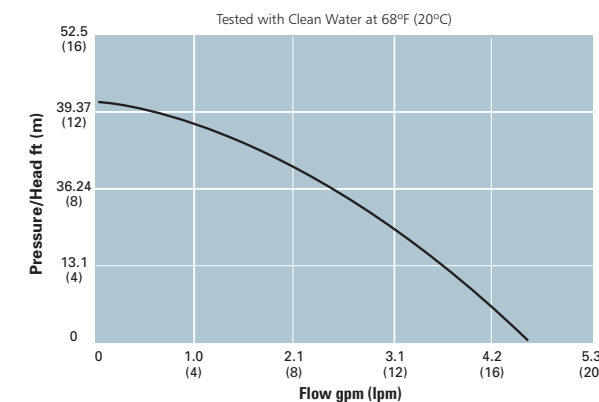

NEMP 20/18

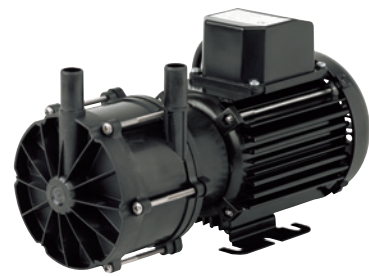

Specifications

Pump Design	Magnetically Coupled Centrifugal Pump
Open Flow	4.9 GPM (18.5 LPM)
Max Head	60.7ft (18.5m)
Motor Output	90 watts
Amp Draw	1.8
Max Specific Gravity*	1.2
Temperature Range	-4°F to 185°F (-20°C to 85°C)
Weight	8.4lbs (3.8kg)

*Assuming maximum viscosity of 30cp.

Dimensional Drawings

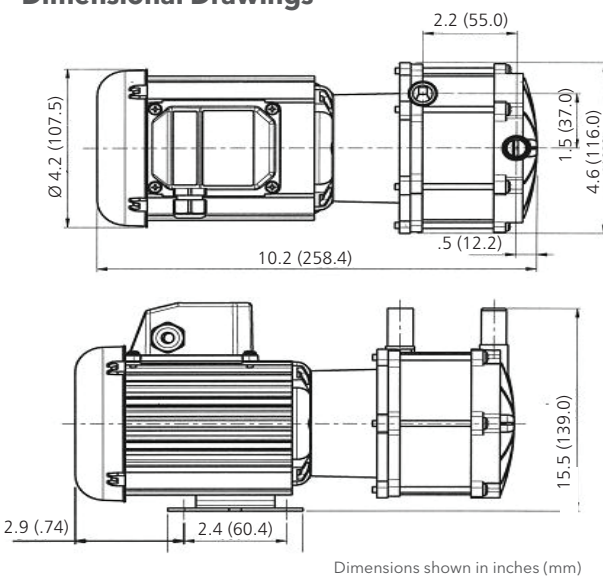

Performance

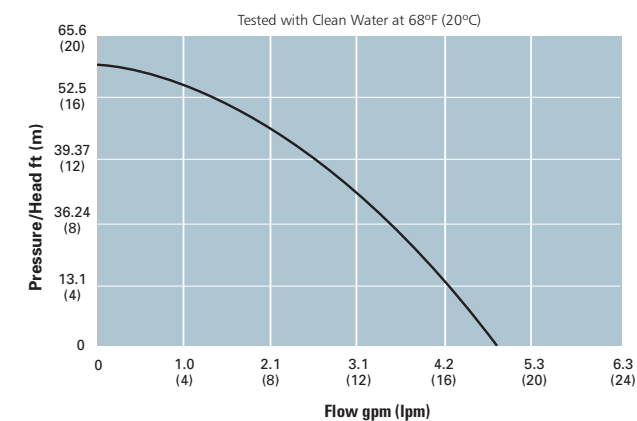

NEMP 25/5

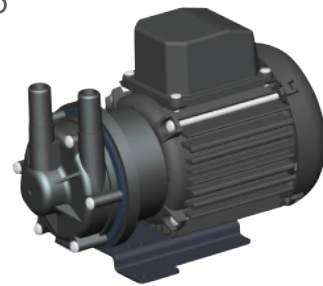

Specifications

Pump Design	Magnetically Coupled Centrifugal Pump
Open Flow	8.5 GPM (32 LPM)
Max Head	17.4ft (5.3m)
Motor Output	35 Watts
Amp Draw	0.75
Max Specific Gravity*	1.2
Temperature Range	-4°F to 185°F (-20°C to 85°C)
Weight	5.3lbs (2.4kg)

*Assuming maximum viscosity of 30cp.

Dimensional Drawings

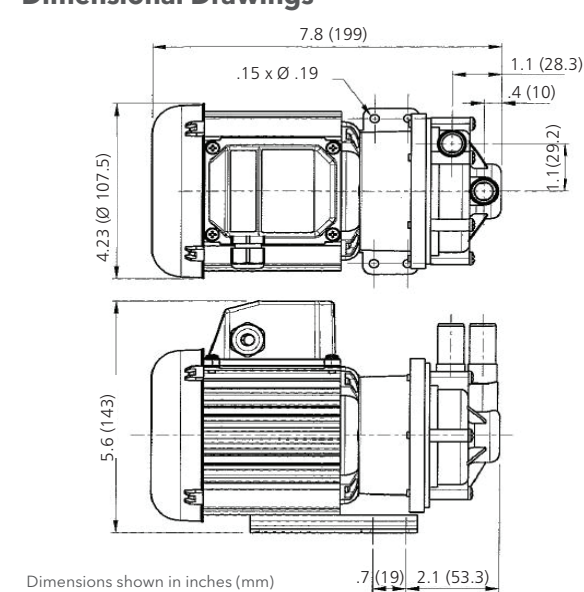

Performance

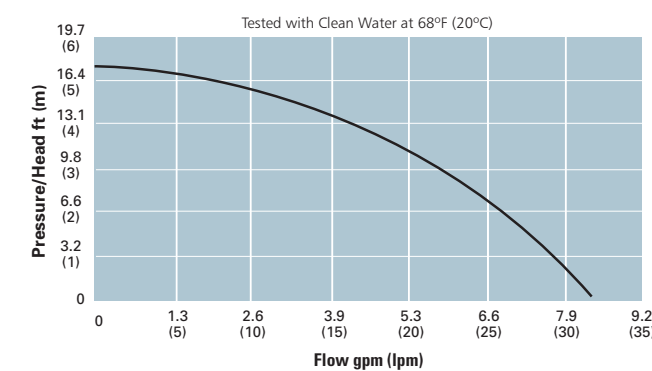

NEMP 40/6

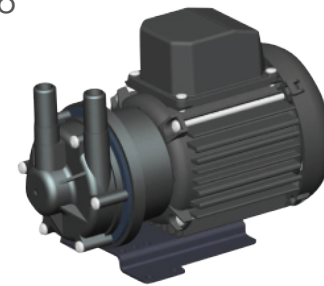

Specifications

Pump Design	Magnetically Coupled Centrifugal Pump
Open Flow	11.4 GPM (43 LPM)
Max Head	21.3ft (6.5m)
Motor Output	60 Watts
Amp Draw	0.95
Max Specific Gravity*	1.2
Temperature Range	-4°F to 185°F (-20°C to 85°C)
Weight	6.6lbs (3kg)

*Assuming maximum viscosity of 30cp.

Dimensional Drawings

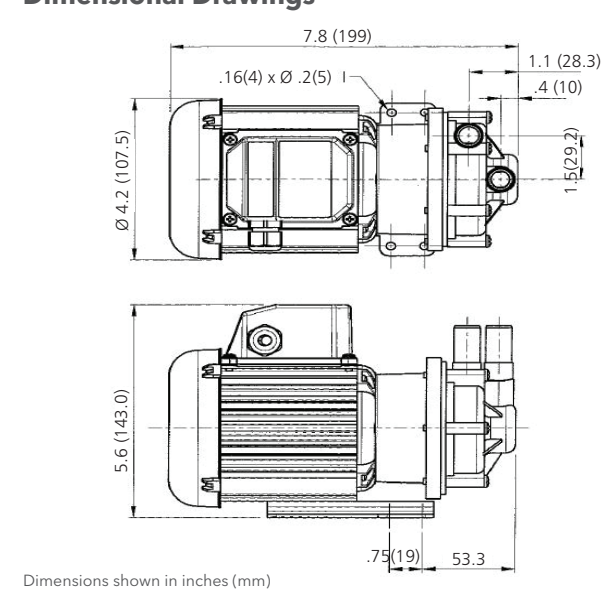

Performance

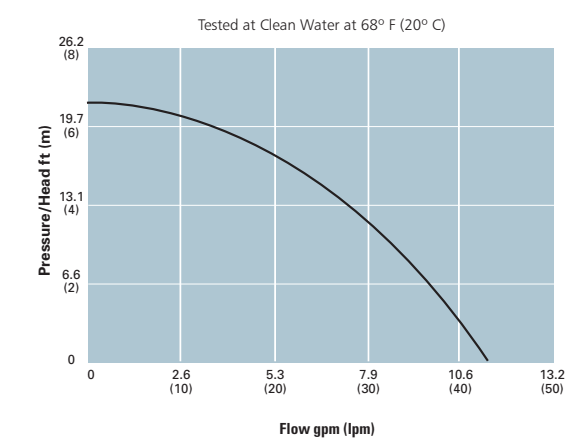

NEMP 50/7



Dimensional Drawings

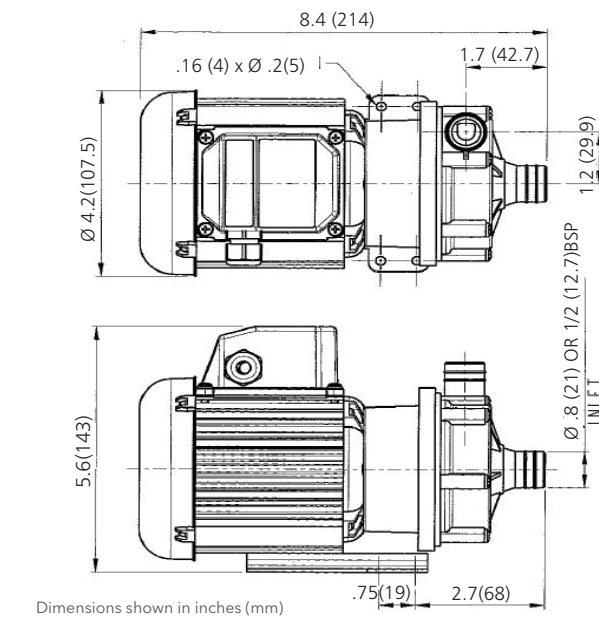

Specifications

Pump Design	Magnetically Coupled Centrifugal Pump
Open Flow	13.7 GPM (52 LPM)
Max Head	22.3ft (6.8m)
Motor Output	60 Watts
Amp Draw	0.95
Max Specific Gravity*	1.2
Temperature Range	-4°F to 185°F (-20°C to 85°C)
Weight	6.6lbs (3kg)

*Assuming maximum viscosity of 30cp.

Performance

