

## Heavy Duty, Magnetic driven, Seal-less, Circulating pumps

FLANGED TO 12/24/32 V DC MOTOR CM10P7-1, CM30P7-1

ORIGINAL INSTRUCTIONS/TRANSLATION OF ORIGINAL INSTRUCTIONS  
READ AND UNDERSTAND THIS MANUAL PRIOR TO OPERATING OR SERVICING THIS  
PRODUCT



# Cirkulation pump CM10/30

## Typical applications

- Circulation of water/antifreeze in heating system for cars, boats, recreation vehicles, etc.
- Circulation for cooling fresh water in vehicles.
- All-round pumps wherever self-priming is not essential.

## Technical description

Body:	Glass reinforced plastic (PPA, GF 30%)
Shaft:	Stainless steel
Wear plate:	Stainless steel
O-ring:	EPDM
Impeller:	Body: Glass reinforced plastic (PPS, GF 40%) Magnet: Ferrit Bearing: Resin-bonded carbon
Magnet housing:	Glass reinforced plastic (PSU, GF 30%)
Motor flange:	Glass reinforced plastic (PA66, GF 30%)
Polletube:	Steel, el-plated zink-iron, black chromated
Motor end:	Glass reinforced plastic (PA66, GF 30%)
Screws:	Steel, el-plated zink-iron, black chromated
Motor:	Ball bearing permanent magnet motor, 12/24 V
Motorbracket:	Aluminium, painted
Motor protection:	IP67 (DIN40050)
Connection:	CM10: 16 alt 20 mm hose CM30: 20 mm hose
Radio disturbance shielded:	EN55014

## Type specification

Pump type	Art. No.	Connection
CM10P7-1, 12 V	10-24501-03	16 mm (5/8")
CM10P7-1, 24 V	10-24501-04	16 mm (5/8")
CM10P7-1, 12 V	10-24502-03	20 mm (3/4")
CM10P7-1, 24 V	10-24502-04	20 mm (3/4")
CM30P7-1, 12 V	10-24503-03	16 mm (5/8")*
CM30P7-1, 24 V	10-24503-04	16 mm (5/8")*
CM30P7-1, 12 V	10-24504-03	20 mm (3/4")
CM30P7-1, 24 V	10-24504-04	20 mm (3/4")

\* CM30P7-1 with 16 mm connection on request

## Pressure and capacity data (see page 18)

Based on water at 20°C (68°F)

## Spare parts (see page 17)

## Installation recommendation

The CM-series pumps are normal-priming centrifugal pumps and should be mounted in a manner that ensures that they are always flooded or else be primed before being switched on.

The pump should not be run dry, even if it stands a shorter time of dry running. Max dry running 30 min. Note! Noise at dry running. The direction of rotation of the pump is clockwise, viewed from the front towards the body (see rotation arrow).

The motors are made for continuous duty and for voltage fluctuation of  $\pm 20\%$ . Capacity data (page 18) is for the rated voltage. Over-voltage reduces component life.

Temperature ranges:

Liquid:  $-40^{\circ} - +100^{\circ}\text{C}$

Ambient:  $-40^{\circ} - +70^{\circ}\text{C}$

Max system pressure: 2.5 bar.

The pumps should not be used for soiled water containing hard particles.

## > English

### Important!

The pumps can be installed in optional position, horizontally or vertically.

To avoid air-locks when mounted horizontally, the outlet should be turned in such a way that it is directed upwards or is placed on the upper side of the pump body.

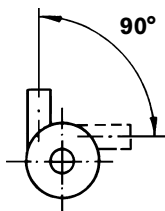

### Elektrical installation

Connect red lead to positive (+) terminal and black lead to negative (-) terminal.

#### Electrical installation in boat

The pump must be installed according to ISO 10133 (Small craft - Electrical system - Extra low voltage DC installation for continuous current). Other electrical devices, eg switch, circuit breaker, must be installed between the pump and the positive (+) lead on the battery (on the red wire). Note: The fuse must be ignition protected.

All electrical connections must be placed above highest bilge water level.

All wire connections ought to be sealed with a marine sealant, e g vaseline, silicon rubber or grease. If the pump is connected with separate earth lead, this should be yellow/green and connected to the motor base. See the wiring scheme for correct installation. Negative wire must be black. Choose wire size in accordance with total wire length (see table).

Note: Before installation with electrical control systems, check that equipment to be used is of sufficient rated capacity to accept ampere draw of motor.

### Wiring dimensions

(based on 3% voltage drop)

Wire size	Max wire length in mm*	
	12 V	24 V
1.0 mm <sup>2</sup>	11 m	44 m
1.5 mm <sup>2</sup>	16.5 m	
2.5 mm <sup>2</sup>	27.4 m	

\* The wire length is the total distance from the battery to the pump and back to the battery.



### Caution

Do not pump gasoline, solvents, thinners, highly concentrated or organic acids. If corrosive fluids must be handled, pump life will be prolonged if flushed with water after each use or after each work day.

### Wiring scheme

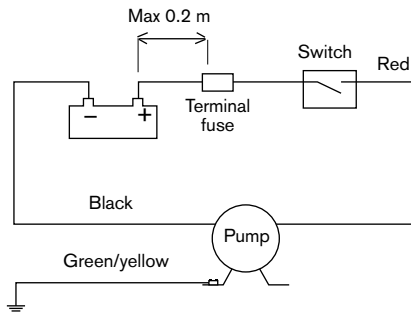

### Waste handling material recycling

At the products end of life, please dispose of the product according to applicable law. Where applicable, please disassemble the product and recycle the parts material.

## Dimensions and weight

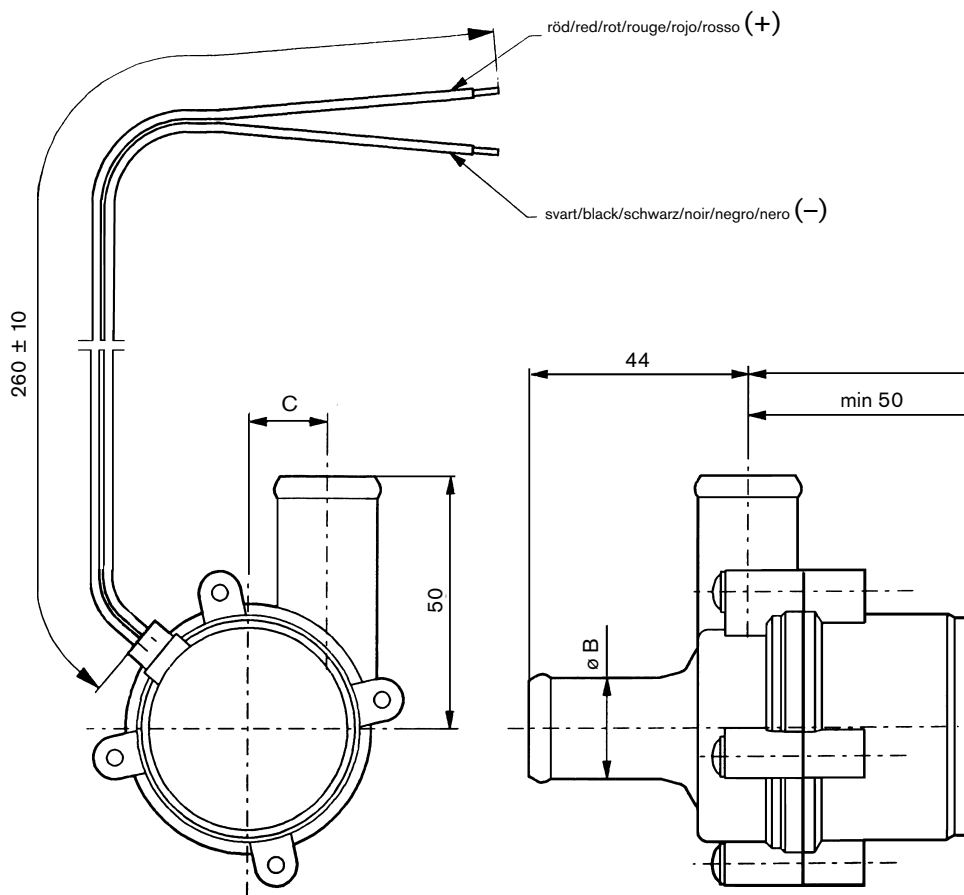

	$\varnothing A$	$\varnothing B$	C	Vikt/Weight/Gewicht Poids, Peso
CM10P7-1 $\varnothing 16$	17.7	16.2 (5/8")	17.3	0.53 kg
CM10P7-1 $\varnothing 20$	21.4	20.0 (3/4")	15.8	0.53 kg
CM30P7-1 $\varnothing 16$	17.7	16.2 (5/8")	17.3	0.60 kg
CM30P7-1 $\varnothing 20$	21.4	20.0 (3/4")	15.8	0.60 kg

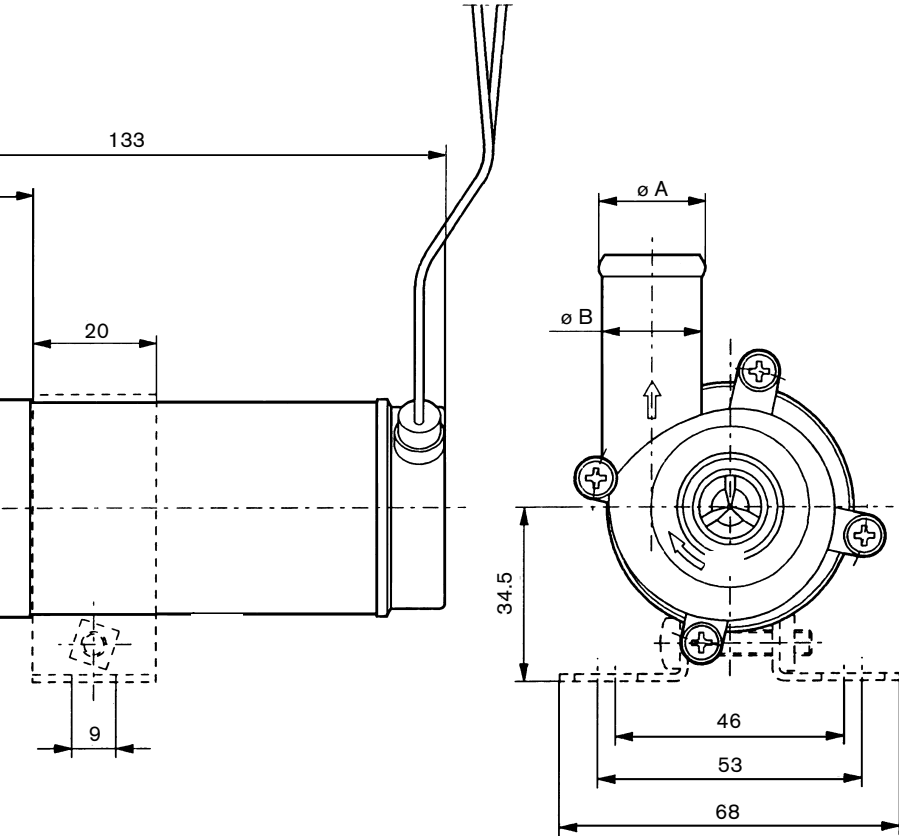

## Parts list

Pos	Nos	Description
1	1	Body, ø 16
		Body, ø 20
2	1	Impeller
3	1	O-ring
4	4	Screw
5	1	Motor bracket
6	1	Washer
7	1	Shaft
8	1	Gasket
9	1	Magnet housing

\*) incl pos 3, 4      \*\*) incl pos 6, 7

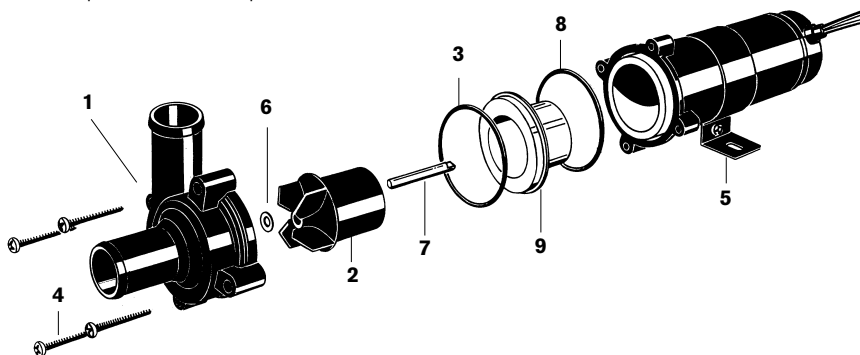

Pos	Nos	Description	Art No
1	1		09-46549*)
			09-46550*)
2	1		09-46551**)
3	1		0.2173.020
4	4		0.0145.002
5	1		36-503-023
6	1		01-46792-01
7	1		01-46317
8	1		01-46552
9	1		01-35733

\*) incl pos 3, 4      \*\*) incl pos 6, 7

## ENGLISH

Pressure and Capacity		Back pressure			Flow		Amperage	
		Bar	kPa	ft	l/min	USGPM	12 V	24 V
CM10P7-1	Hose connection ø 16 mm (5/8")	0.10	10	3.3	15.0	4.0	1.2	0.6
		0.15	15	4.9	12.0	3.2	1.1	0.55
		0.20	20	6.6	7.3	1.9	0.9	0.5
	Fuse required					1.6	0.8	
CM10P7-1	Hose connection ø 20 mm (3/4")	0.10	10	3.3	18.5	5.0	1.2	0.6
		0.15	15	4.9	14.5	3.9	1.1	0.55
		0.20	20	6.6	9.0	2.4	1.0	0.5
	Fuse required					1.6	0.8	
CM30P7-1	Hose connection ø 16 mm (5/8")*	0.10	10	3.3	20.0	5.3	1.9	0.9
		0.20	20	6.6	16.0	4.2	1.75	0.8
		0.30	30	9.8	7.5	2.0	1.4	0.75
	Fuse required					3.0	1.6	
CM30P7-1	Hose connection ø 20 mm (3/4")	0.10	10	3.3	26.0	6.9	2.2	1.1
		0.20	20	6.6	19.5	5.2	2.0	1.0
		0.30	30	9.8	9.0	2.4	1.7	0.75
	Fuse required					3.0	1.6	

\* available on request