

## Ultima Bilge

600GPH, 800GPH, 1000GPH, 1250GPH

IB-123 R02 (09/2012)

ORIGINAL INSTRUCTIONS/TRANSLATION OF ORIGINAL INSTRUCTIONS  
READ AND UNDERSTAND THIS MANUAL PRIOR TO OPERATING OR SERVICING THIS  
PRODUCT



# Ultima Bilge - Automatic Bilge Pump

Caution: Please read and follow all instructions before installing and using this product.

Always disconnect power sources during installation, servicing or maintenance of this product. The Ultima Bilge pump has been carefully designed to exhaust standing water only. These pumps are not intended for damage control. Bilge pump capacities may not be sufficient to prevent flooding from rapid accumulation of water due to storms, rough weather and/or rapid leaks created by hull damages and/or unsafe navigational conditions.

## **About the Ultima Bilge Pump**

The Ultima Bilge pump is a state of the art automatic bilge pump that uses advanced electronic sensing technology to detect the presence of water in the bilge area of a boat and consequently discharge of that water. It is built upon the proven UltimaSwitch technology which uses micro electrical fields to detect the presence of water. The Ultima Bilge pump is a sealed, submersible pump and electronic float switch that allows for a simple installation for the end user.

## **Warnings:**

To eliminate personal injury or damage to property during installation, servicing and maintenance, make sure to disconnect electrical power. This pump was designed to remove standing bilge water only and should not be used to pump petroleum products such as gasoline, oil, or flammable liquids.

Make sure to use the appropriate fuse size recommended by your pump model. Using the wrong fuse can lead to personal injury, property damage and fire hazard.

## **Installing the Ultima Bilge Pump:**

**Caution:** When installing the Ultima Bilge Pump, make sure that pump is clear of all obstacles, especially near the detector area. If detectors are blocked, the pump will remain continuously on!

- 1) Place a 3/4" thick block of marine plywood as a mounting block for your pump base. Mounting block should be large enough to cover the strainer area. Use a waterproof adhesive to attach mounting block to the hull of the vessel. Make sure that mounting block is as flat as possible. Place pump in the lowest area of the bilge. Also, make sure discharge nozzle is level.
- 2) Remove the pump from the strainer by depressing the two side tabs and pulling the strainer from pump body. Use the strainer to mark three mounting holes. In order to avoid drilling through the hull of the vessel, set your drill to the appropriate depth for the pilot holes. Drill your pilot hole.
- 3) Drive three #8 x 5/8" (not supplied) Stainless screws into the strainer holes to mount the strainer. Do not over tighten.
- 4) After the strainer is mounted down, place pump body onto strainer making sure that the side tabs lock onto pump body.

For 3/4" discharge models attach your hose over the Duraport. Use Stainless steel hose clamps to secure the hose. If installing the optional check valve, make sure to install the check valve into the Duraport before installing the hose. For 1 1/8" models attach your hose over threaded port [1 1/8" or 1 1/4"]. Use Stainless Steel hose clamps to secure the hose to the ports. If installing the optional check valve, make sure to

install the check valve before installing the hose and ports. The check valve for the [1 1/8" or 1 1/4"] model will include a stainless steel washer and a flapper. To install the check valve, place stainless steel washer into the discharge area of pump. Next place the Nitrile flapper over the washer. Then thread on the port on to pump's discharge. Tighten port until port is bottomed out with pump body.

For 3/4" model install check valve such that the tapered end is towards the direction of flow. To install check valve, remove gasket in Duraport and replace the gasket with the check valve which also acts as the gasket. Save the old gasket in case you intend to not use the check valve at a later time. Make sure to avoid loops or bends in the hose. Support hose if necessary. It is important that the hose be constantly rising and not be allowed to dip below the outlet port as this may cause an airlock situation. For maximum performance use smooth bore, reinforced hose.

**NOTE:** The check valve supplied with your Ultima Bilge pump is used to prevent the backflow of water. The utilization of the check valve requires you to be mindful of its functionality. The check valve material is made of Nitrile material to be used for water applications only. Also, the check valve will reduce the flow of the pump. If flow is critical to the application of the pump, it is recommended that the check valve not be used. Also, when winterizing your boat, remove the check valve to avoid ice formation and/or degradation of the check valve.

**Place fingers on circles to test the pump**

Leave 1" of clearance between sensor and any object nearby

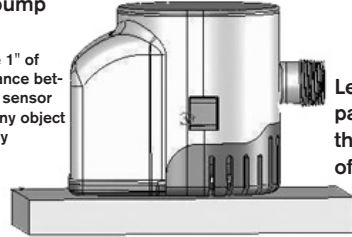

Level, parallel to the bottom of the boat

**Mounting block**

### ***Wiring Instructions:***

Refer to wiring diagram below. Use appropriate sized connectors for 16 Gauge wire. The wiring connections should be made with water resistant permanent terminals. Liquid electrical tape should be used to coat terminals. The mount connections should be above the highest water level. The warranty will become void on this product if any electrical cord is cut back more than 3 inches, if electrical splices become submerged, failure to properly fuse or if pump is installed contrary to instructions or warnings.

You may install a three way switch panel that will allow the pump to be in manual or automatic mode. Make sure to fuse the pump. The fuse holder should be between positive battery terminal and three way panel switch. Make sure to use the appropriate fuse size for the models. To check the operation of the pump, place two fingers over the raised circular areas in the back of the pump. After a short delay [5 seconds], the pump should turn on. If you remove your finger from the top circle, the pump should remain on. If you remove both fingers, the pump should turn off.

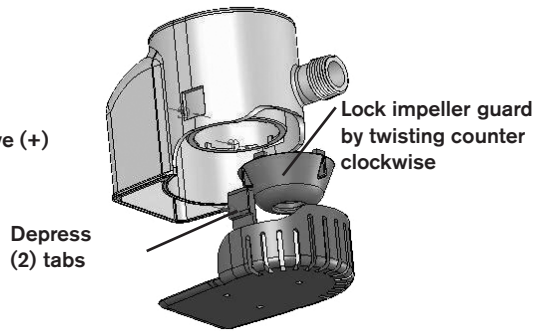
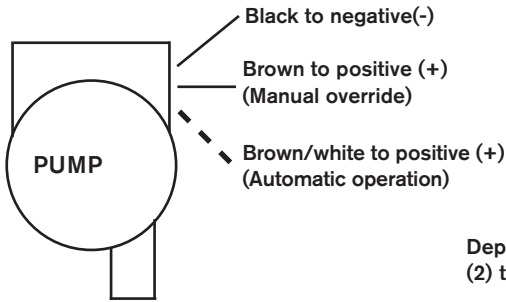

\*\*\*Make sure to have at least 1 inch [25MM] of clearance from the sensors on the Ultima Bilge pump to any wall or surroundings. If there is not enough clearance, the sensors may detect the object and leave the pump running continuously.\*\*\*

### **Maintenance:**

The Ultima bilge pump is designed to be worry free and maintenance free. However, care should be taken to make sure that the impeller is clear of debris for optimum pump functionality. Make sure power is disconnected during maintenance of the pump. To access the impeller, remove pump from strainer by depressing the side lock tabs on pump body and pulling pump from strainer. To clean the impeller, grab on to impeller guards fins and rotate impeller guard clockwise and pull straight out. Remove and clean the impeller and pump from all debris that has accumulated. Make sure to clean any debris that has accumulated on the strainer as well. After the impeller is clean, replace impeller guard by aligning tabs with slots and turning counter-clockwise, making sure not to over tighten. The guard should be rotated until it is firm. Place pump body on to strainer making sure that both locking tabs snap onto pump body.

### **Warranty Information**

Johnson Pumps of America of 1625 Hunter Road, Suite B, Hanover Park, Illinois 60133 warrants to the original consumer purchaser that this product will be free from defects in material and workmanship, providing that the case is not opened or the pump otherwise abused for a period of three (3) years from the date originally purchased.

## Wiring Scheme

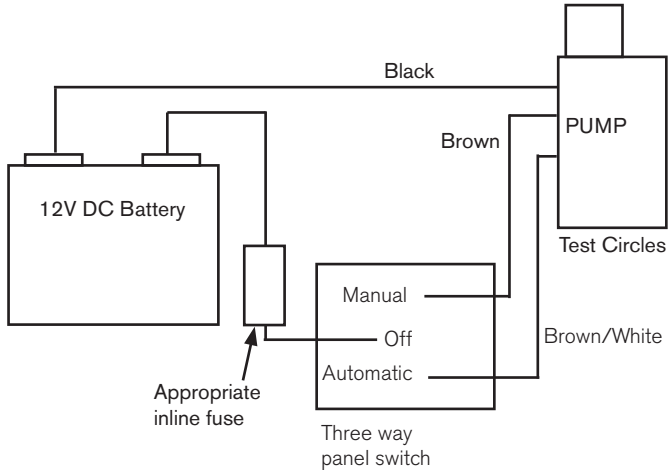

If you are using a 3-way switch, you can wire your pump to operate in the manual over-ride or automatic operation.

As shown in the diagram, connect the black (-) ground wire to the negative terminal of the battery. For manual over-ride operation, connect the brown wire from the pump to the switch panel. For automatic operation, connect the brown wire with white tracer to the switch panel. Make sure to connect an appropriate in line fuse coming from the positive terminal of the battery to the switch panel as shown.

## Wiring scheme without Panel switch

