



JOHNSON PUMP
AN SPX BRAND

Instruction Manual
Aqua Jet
Wash Down Systems
WD 2.9, 3.5 & 5.2, 12/24 V DC



SPX[®]

Wash Down Systems WD 2.9, WD 3.5 and WD 5.2 mounted to DC motor 12/24 V

Typical applications

The WD pumps are five chamber positive displacement diaphragm pumps.

These pumps are the ideal choice for wash down applications as they provide 2.8 bar pressure (WD 2.9) or 5 bar/ 70psi pressure (WD 3.5 and WD 5.2), making clean-up faster and easier.

Features

- Quiet operation
- Smooth flowing
- Self priming
- Integrated pressure switch turns pump on and off automatically when the spray nozzle is opened and closed
- Dry running without damage
- Low power consumption
- Quick disconnect fittings

Working principle

As the pump runs, pressure is increased until it reaches the pre-defined pressure level, see page 40. When the pre-defined pressure level is reached the integrated pressure switch automatically shuts the pump off.

The pump is equipped with positively checking outlet valves which ensure that the pressure is maintained after the pump shuts off.

When water is demanded the pressure decreases. After a moderate drop in pressure, the integrated pressure switch automatically turns the pump back on.

Due to their durable construction and thoughtful design, the WD-pumps will provide many years of service.

Important! The pressure setting of this pump is made at the factory. Warranty invalidated by pressure switch interference.

Technical description

Body:	Nylon/Polyamide
Valve housing:	Polypropylene/Polyamide
Valves:	Nitrile
Diaphragm:	Santoprene
Connection:	3/8" BSP, 1/2" hose (Ø 13 mm) or US: 1/2" NPT, 3/4" hose (Ø 13 mm) 3/4" Garden hose thread (GHT)
Max. liquid temperature:	Max +50°C/+120°F
Fasteners:	Stainless steel
Max. suction lift:	WD 2.9 2 m/ WD 3.5 – 2.5 m/8.2 ft WD 5.2 – 3 m/9.8 ft
Cut in pressure:	See page 40
Cut-off pressure:	See page 40
Duty cycle:	Intermittent, max 20 min
Motor:	WD 2.9 – 85 W WD 3.5 – 120 W WD 5.2 – 185 W 12/24 V DC with built in thermal protection

The motor is ignition protected according to ISO 8846 (Small craft – Electrical devices – Protection against ignition of surrounding flammable gases).

Type designation

See page 40

Pressure and capacity data

(based on water at +20°C/68°F and at full voltage of the motor)

WD 2.9

Pressure			Flow		Amp. draw	
Bar	kPa	Psi	l/min	USGPM	12V	24V
0	0	0	9,4	2,4	2,5 A	1,1 A
0,4	40	5,8	8,8	2,3	3,3 A	1,4 A
0,8	80	11,6	8,1	2,1	4,0 A	1,8 A
1,2	120	17,4	7,3	1,9	4,6 A	2,1 A
1,6	160	23,2	6,7	1,8	5,2 A	2,4 A
2,0	200	29	5,8	1,5	5,8 A	2,7 A
2,4	240	29	4,9	1,3	6,4 A	3,0 A
2,8	280	40,6	4,1	1,1	6,9 A	3,2 A
Fuse required					10 A	5 A

WD 3.5

Pressure			Flow		Amp. draw	
Bar	kPa	Psi	l/min	USGPM	12V	24V
0	0	0	12,2	3,2	2,6 A	1,2 A
0,5	50	7,3	11,5	3,0	3,5 A	1,6 A
1,0	100	14,5	11,4	3,0	4,2 A	2,1 A
1,5	150	21,8	11,0	2,9	5,2 A	2,5 A
2,0	200	29,0	10,6	2,8	5,9 A	2,8 A
2,5	250	36,3	10,2	2,7	7,0 A	3,3 A
3,0	300	43,5	9,9	2,6	7,7 A	3,7 A
3,5	350	50,8	9,6	2,5	8,8 A	4,0 A
4,0	400	58,0	9,3	2,5	10,0 A	4,5 A
4,5	450	65,3	9,1	2,4	10,4 A	4,8 A
Fuse required					20 A	10 A

WD 5.2

Pressure			Flow		Amp. draw	
Bar	kPa	Psi	l/min	USGPM	12V	24V
0	0	0	18,9	5	3,6 A	1,7 A
0,5	50	7,3	17,8	4,7	5 A	2,4 A
1,0	100	14,5	16,6	4,4	6,6 A	3 A
1,5	150	21,8	15,5	4,1	7,8 A	3,6 A
2,0	200	29	14,5	3,8	9,1 A	4,2 A
2,5	250	36,3	13,4	3,5	10,4 A	4,8 A
3,0	300	43,5	12,4	3,3	11,7 A	5,2 A
3,5	350	50,8	11,4	3	13 A	5,7 A
4,0	400	58	10,6	2,8	13,8 A	6,2 A
4,5	450	65,3	9,7	2,6	14,8 A	6,5 A
5,0	500	72,5	8,7	2,3	15,9 A	7 A
Fuse required					20 A	10 A

Installation and maintenance

Installation

Locate the pump in a dry location.

If the pump is mounted vertically, the motor shall face up.

Mark screw positions and drill pilot holes (see drilling template page 48). Mount the pump using stainless steel screws and with the accompanying washers (over the rubber feet); taking care not to over compress the vibration dampening rubber feet.

Reinforced, high pressure flexible tubing is recommended. If rigid pipe is used, a length (225 mm/9 inches minimum) of flexible tubing shall be installed between the pump and the rigid pipe. This will address noise and/or damage caused by vibration transmitted to rigid pipe.

Use stainless steel hose clamps to secure tubing to quick disconnect fittings and other hose barbs in the system.

A strainer must be installed in line before the pump intake, to prevent debris from entering pump and interfering with proper functioning of valves.

Electrical installation

The pump must be installed according to ISO 10133 (Small craft – Electrical system – Extra low voltage DC installation for continuous current). Note: The fuse must be ignition protected.

The motor is equipped with built in thermal protection to prevent the motor from overheating. The protection is automatically restored when the motor is cooled.

If the pump is connected with separate earth lead, this should be yellow/green and connected to the motor base.

See the wiring table (next page) for correct installation. Negative wire must be black.

Choose wire size in accordance with total wire length (see table next page).

The wire connections must be sealed with a marine sealant.

Note: Before installation with electrical control systems, check that equipment to be used is of sufficient rated capacity to accept amperage draw of motor. Low voltage will cause motor to overheat.

Wiring table

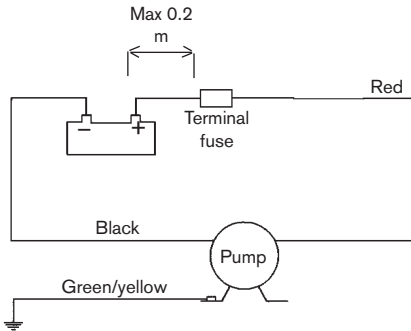

Other electrical devices, eg switch, circuit breaker, must be installed between the pump and the positive (+) lead on the battery (on the red wire).

Wiring dimensions

(based on 3% voltage drop)

WD 2.9

Wire size		Max wire length* in m	
		12 V	24 V
1,5 mm ²	# 16 AWG	5	21
2,5 mm ²	# 14 AWG	8	34
4,0 mm ²	# 12 AWG	13	55
6,0 mm ²	# 10 AWG	19	82

WD 3.5

Wire size		Max wire length* in m	
		12 V	24 V
2,5 mm ²	# 14 AWG	3	16
4,0 mm ²	# 12 AWG	6	25
6,0 mm ²	# 10 AWG	8	38
10 mm ²	# 6 AWG	14	63

WD 5.2

Wire size		Max wire length* in m	
		12 V	24 V
2,5 mm ²	# 14 AWG	3	16
4,0 mm ²	# 12 AWG	6	25
6,0 mm ²	# 10 AWG	8	38
10 mm ²	# 6 AWG	14	63
16 mm ²	# 4 AWG	22	100

* The wire length is the total distance from the battery to the pump and back to the battery. It is recommended to use a relay with a light wire from main cable to switch to shorten the main leaders.

Start-up procedure

After pump installation, the system can be started by using the following procedure:

- Make sure suction hose is connected to the water supply.
- Open the spray nozzle and start the pump.
- Close the spray nozzle when water begins flowing and all air has been purged from the system.
- If additional spray nozzles or taps are in use after the pump, open each additional nozzle/tap until all air has been purged from the system.
- Pump will cut off after taps are closed and pressure builds to the setpoint of the pressure switch

Self-priming

The pump is self-priming up to 2m for WD 2.9, 2,5m for WD 3.5 and 2,5m for WD 5.2 and. The inlet pipe must be airtight to ensure self-priming

Dry running

Pump will not be damaged by shorter period of dry running. It will, however, unnecessary reduce your battery power.



Caution

Do not use pump for any other liquids than fresh-water and sea-water.

Temperature

Max liquid temperature: +50°C/+120°F

Max ambient temperature: +60°C/+140°F

Winterizing

If water is not drained from the system during freezing temperatures, damage is likely to be sustained in the plumbing and in the pump. To prevent damage follow the instructions beneath:

1. Disconnect suction hose from water supply (sea water supply) or if water supply is taken from a tank, drain water storage tank.
2. Open all spray nozzles/taps.
3. Run pump until remaining water is expelled.
4. Disconnect inlet and outlet tubes.
5. Run pump briefly to confirm that water has been expelled.
6. Spray nozzles/taps shall remain open and pump fittings shall remain disconnected until temperatures are above freezing

Never start a frozen pump. Even if it is drained it might contain a small amount of frozen water that locks the rotor.

Service instructions (see page 42-47)

Change of Switch (pos A) WD

2.9/3.5

1. Remove the cables from the power source.
2. Remove the screws (27) and then remove the complete switch including diaphragm (18).
3. Cut the connection to the motor (red).

4. Locate the new diaphragm (18) and then the new complete switch.
5. Take the new switch and attach the cables to motor and power source. Use the attached jointing sleeve to connect the motor cable.

Change of Switch (pos A) WD 5.2

1. Remove the cables from the power source.
2. Remove the screws (28) and then remove the complete switch including diaphragm (19).
3. Cut the connection to the motor (red).
4. Locate the new diaphragm (19) and then the new complete switch.
5. Take the new switch and attach the cables to motor and power source. Use the attached jointing sleeve to connect the motor cable.

Accessories

(See page 41)

Waste handling & material recycling

At the products end of life, please dispose of the product according to applicable law. Where applicable, please disassemble the product and recycle the parts material.

Trouble-shooting chart

Symptom	Cause	Remedy
1. Pump does not run.	1.1 Tripped thermal protector or blown fuse.	1.1.1 Check fuse. If motor is overheated let it cool down prior to restart.
	1.2 Faulty wire connection or power source.	1.1.2 Check battery/power supply, main switch and wiring.
	1.3 Pressure switch malfunctioning.	1.1.3 Change pressure switch.
	1.4 Motor malfunctioning.	1.1.4 Change pump.
	1.5 Pump/motor frozen.	1.1.5 Thaw pump and system and check for damage. The pump/motor is liable to damage when a frozen pump is started
2. Pump does not prime.	2.1 Water tank empty.	2.1.1 Fill up tank.
	2.2 Debris under valves.	2.1.2 Carefully flush pump with tap water at nominal pump flow. Note! Flush in nominal flow direction.
	2.3 Perforated diaphragm.	2.1.3 Replace diaphragm kit.
	2.4 Leak on inlet side of pump.	2.1.4 Check tightness of hose connections at pump, filter and tank.
	2.5 Inlet or outlet plumbing restricted.	2.1.5 Check plumbing.
3. Pump cycles on and off rapidly while water is demanded.	3.1 Restriction on outlet side of pump/too high pressure.	3.1.1 Outlet hose too small, must be of same diameter as pump connection.
4. Pump cycles on and off rapidly while water is not demanded.	4.1 Leak on outlet side of pump.	4.1.1 Check tightness of hose connections, check hose for possible damage.
5. Pump will not stop running when water is not demanded.	5.1 Leak on inlet side of pump.	5.1.1 Check tightness of hose connections, check hose for possible damage.
	5.2 Leak on outlet side of pump.	5.1.2 Check tightness of hose connections, check hose for possible damage.
	5.3 Perforated diaphragm.	5.1.3 Replace diaphragm kit.
	5.4 Water tank empty	5.1.4 Fill up tank.
	5.5 Pressure switch malfunctioning.	5.1.5 Change pressure switch.
	5.6 Low voltage to pump.	5.1.6 Change battery/power supply.
6. Low flow/pressure.	6.1 Leak on inlet side of pump.	6.1.1 Check tightness of hose connections, check hose for possible damage.
	6.2 Leak on outlet side of pump.	6.1.2 Check tightness of hose connections, check hose for possible damage.
	6.3 Perforated diaphragm.	6.1.3 Replace diaphragm kit.
	6.4 Motor malfunction.	6.1.4 Change pump.
	6.5 Debris under valves.	6.1.5 Carefully flush pump with tap water at nominal pump flow. Note! Flush in nominal flow direction.
7. Pump is excessively noisy.	7.1 Pump is plumbed directly to rigid tubing.	7.1.1 Install flexible tubing according to installation recommendation, see page 9.
	7.2 Pump head loose on motor.	7.1.2 Tighten screws.
	7.3 Pump mounting is loose.	7.1.3 Tighten screws.
	7.4 Pump mounting is too rigid.	7.1.4 Use flexible tubing and make sure the dampening rubber feet are used.
	7.5 Defective motor.	7.1.5 Change pump.

Dimensions and weights

WD 2.9

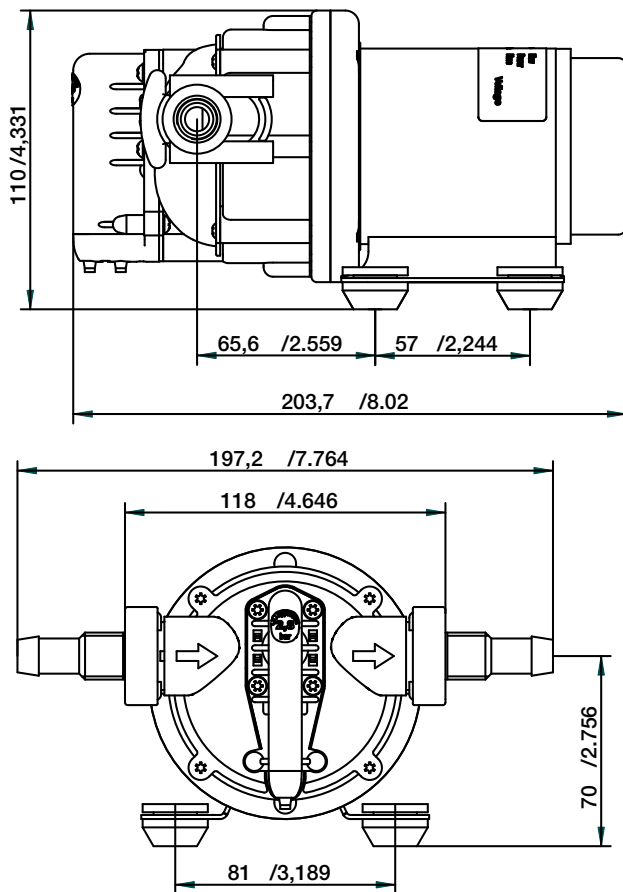

Weight 1,6 kg / 3,5 lbs

Dim. mm/inches

Dimensions and weights

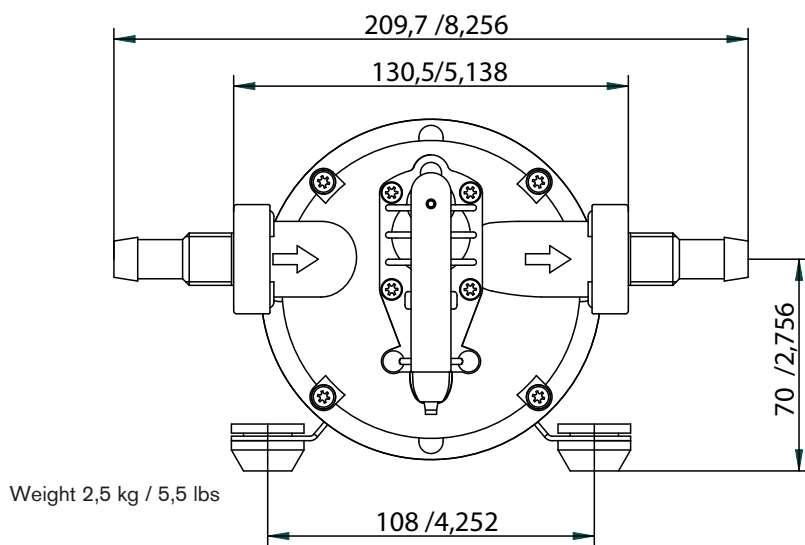
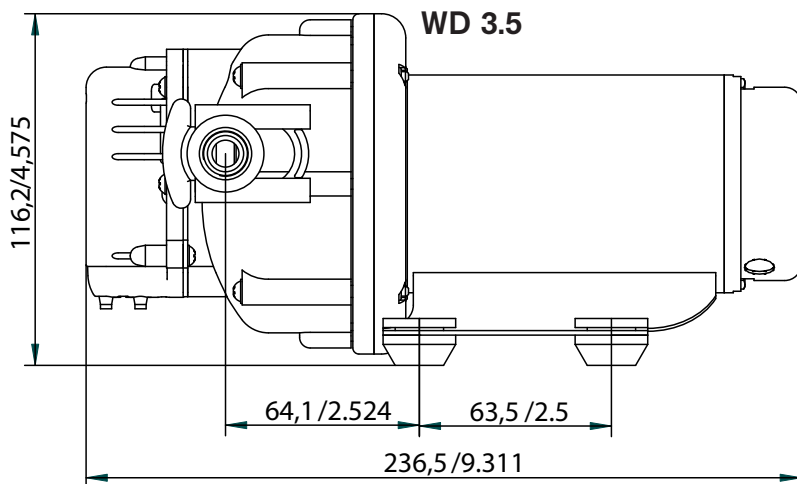

Dimensions and weights

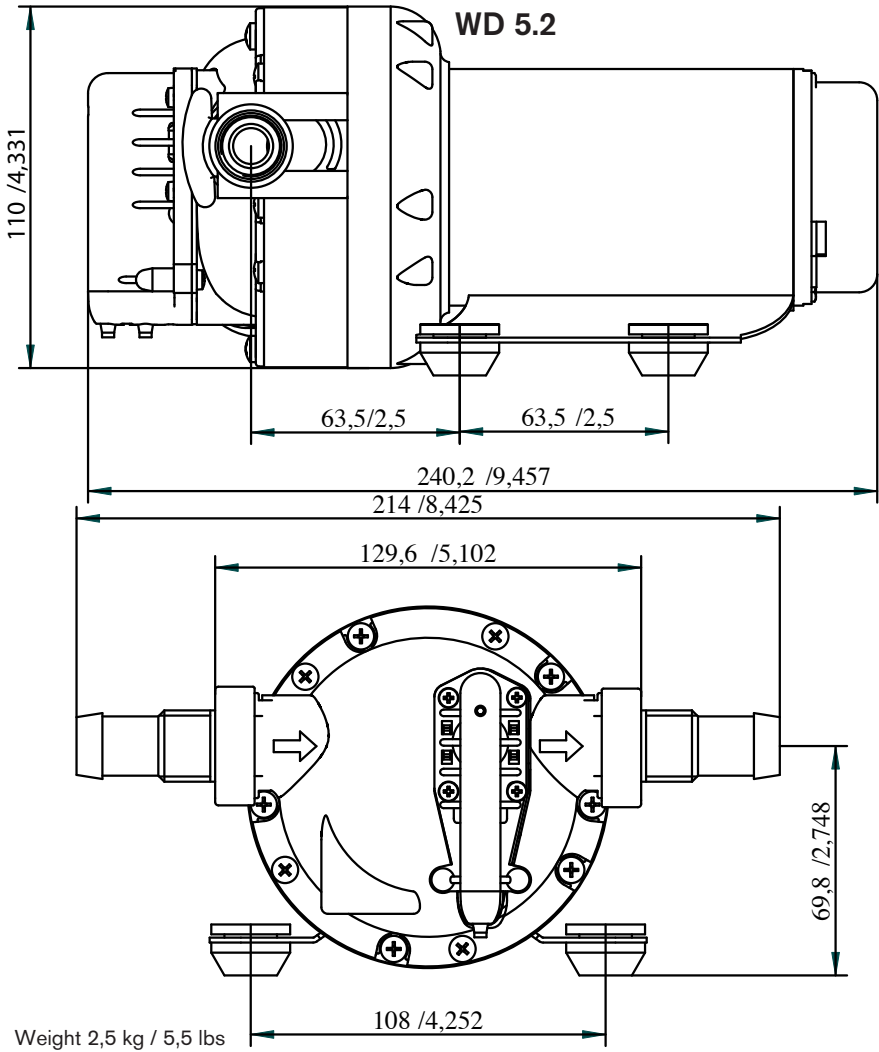

Dim. mm/inches

Type designation & Parts list

Part No	Pump type	cut in/cut out	Switch complete	Pumpbody	Fittings x2 BSP NPT	Fitting retainer x2
10-24728-03	WD 2.9 12V BSP and NPT	1.7/2.8 bar	09-47028-01	09-47282	09-46783	09-46957 09-47278
10-24728-04	WD 2.9 24V BSP and NPT	1.7/2.8 bar	09-47028-01	09-47282	09-46783	09-46957 09-47278
10-13399-03	WD 3.5 12V BSP and NPT	3.7/5 bar	09-47277-02	09-47285	09-46783	09-46957 09-47278
10-13399-04	WD 3.5 24V BSP and NPT	3.7/5 bar	09-47277-02	09-47285	09-46783	09-46957 09-47278
10-13407-07	WD 5.2 12V BSP and NPT	3.7/5 bar	09-46781-02	09-47286	09-46783	09-46957 09-47278
10-13407-08	WD 5.2 24V BSP and NPT	3.7/5 bar	09-46781-02	09-47286	09-46783	09-46957 09-47278

Accessories

PUMProtector™ Universal Strainer

Part. No	Mesh	KlickTite™ Connector
09-24652-01	40	2x 1/2" barb / 3/8" BSP 2x 3/4" barb / 1/2" BSP
09-24652-02	40	2x 1/2" barb / 3/8" NPT 2x 3/4" barb / 1/2" NPT
09-24652-03	20	2x 1/2" barb / 3/8" BSP 2x 3/4" barb / 1/2" BSP
09-24652-04	20	2x 1/2" barb / 3/8" NPT 2x 3/4" barb / 1/2" NPT

PUMProtector™ Inlet Strainer

Part. No	Mesh	KlickTite™ Connector
09-24653-01	40	Built-in KlickTite™ 1x 1/2" barb / 3/8" BSP 1x 3/4" barb / 1/2" BSP
09-24653-02	40	Built-in KlickTite™ 1x 1/2" barb / 3/8" NPT 1x 3/4" barb / 1/2" NPT
09-24653-03	40	Built-in KlickTite™ Bulk pack w/o connectors

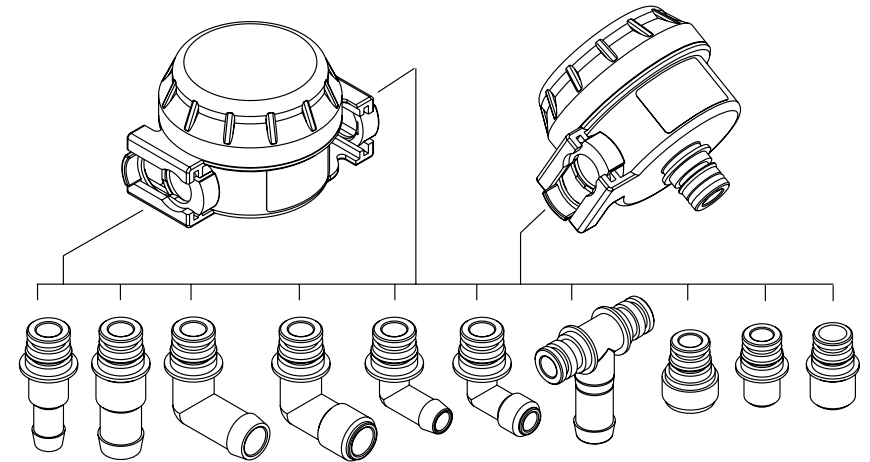

KlickTite™ port connectors available

Part. No.	Connector Description
09-46783	2 x 1/2" barb and 3/8" BSP
09-46784	2 x 3/4" barb and 1/2" BSP
09-46939	2 x 90°, 3/4" barb
09-47087	2 x 90°, 1/2" BSP
09-46938	2 x 90°, 1/2" barb
09-47026	2 x 90°, 3/8" BSP
09-46957	2 x 1/2" barb and 3/8" NPT

KlickTite™ port connectors available

Part. No.	Connector Description
09-46958	2 x 3/4" barb and 1/2" NPT
09-47088	2 x 90°, 1/2" NPT
09-47089	2 x 90°, 3/8" NPT
09-47092	1 x T-connection, 3/4" barb
09-47094	2 x Garden hose adapter
09-47096	2 x 3/8" BSP
09-47098	2 x 1/2" BSP

Inline-strainer

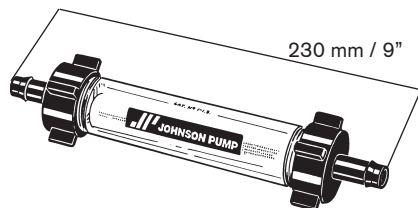

Splitview WD2.9

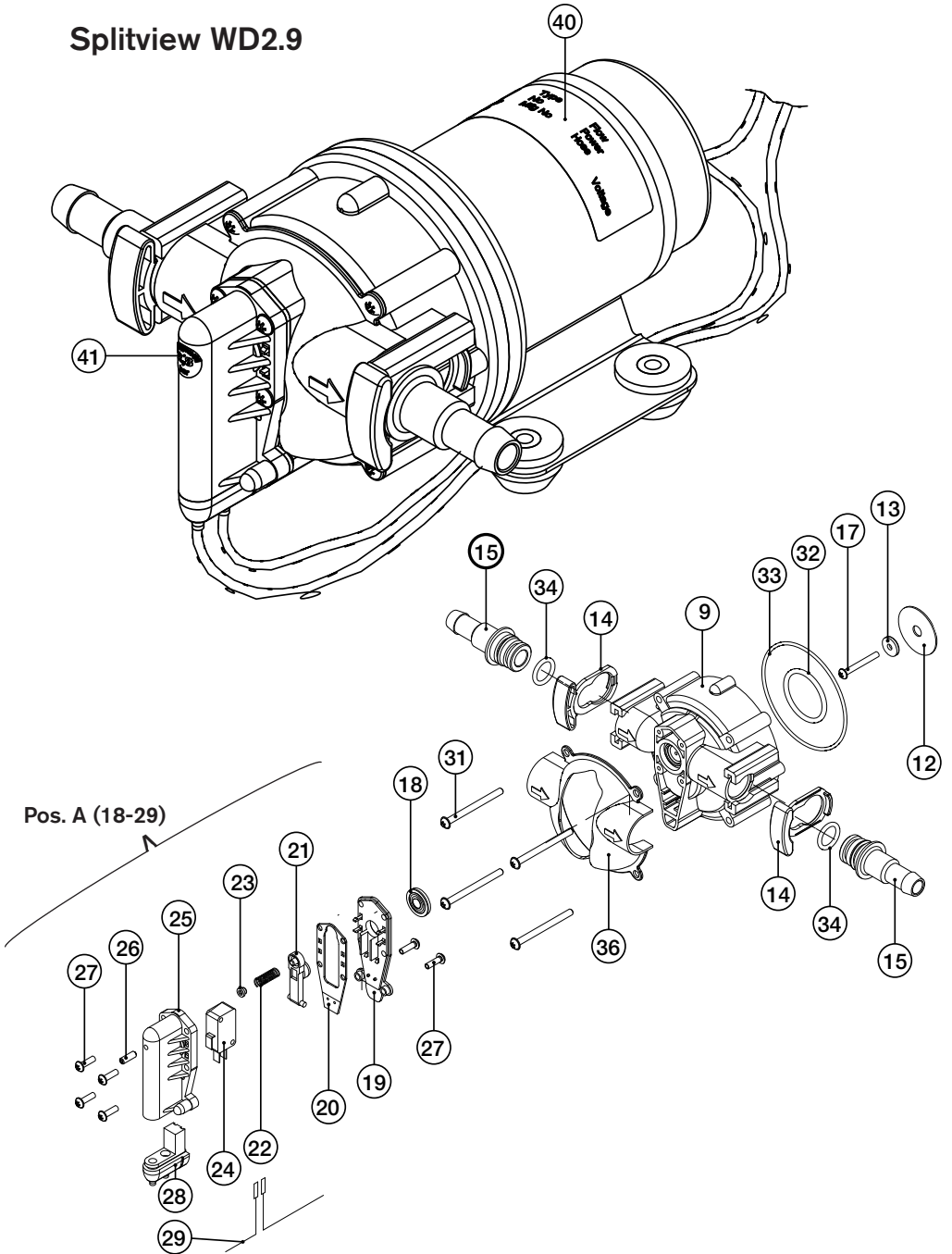

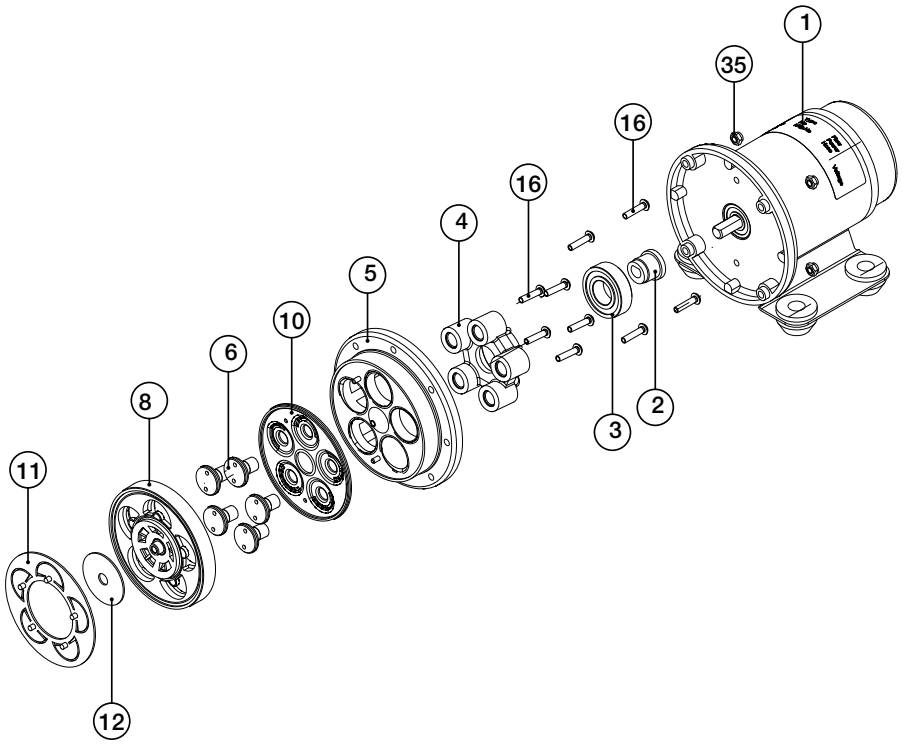

Splitview WD3.5

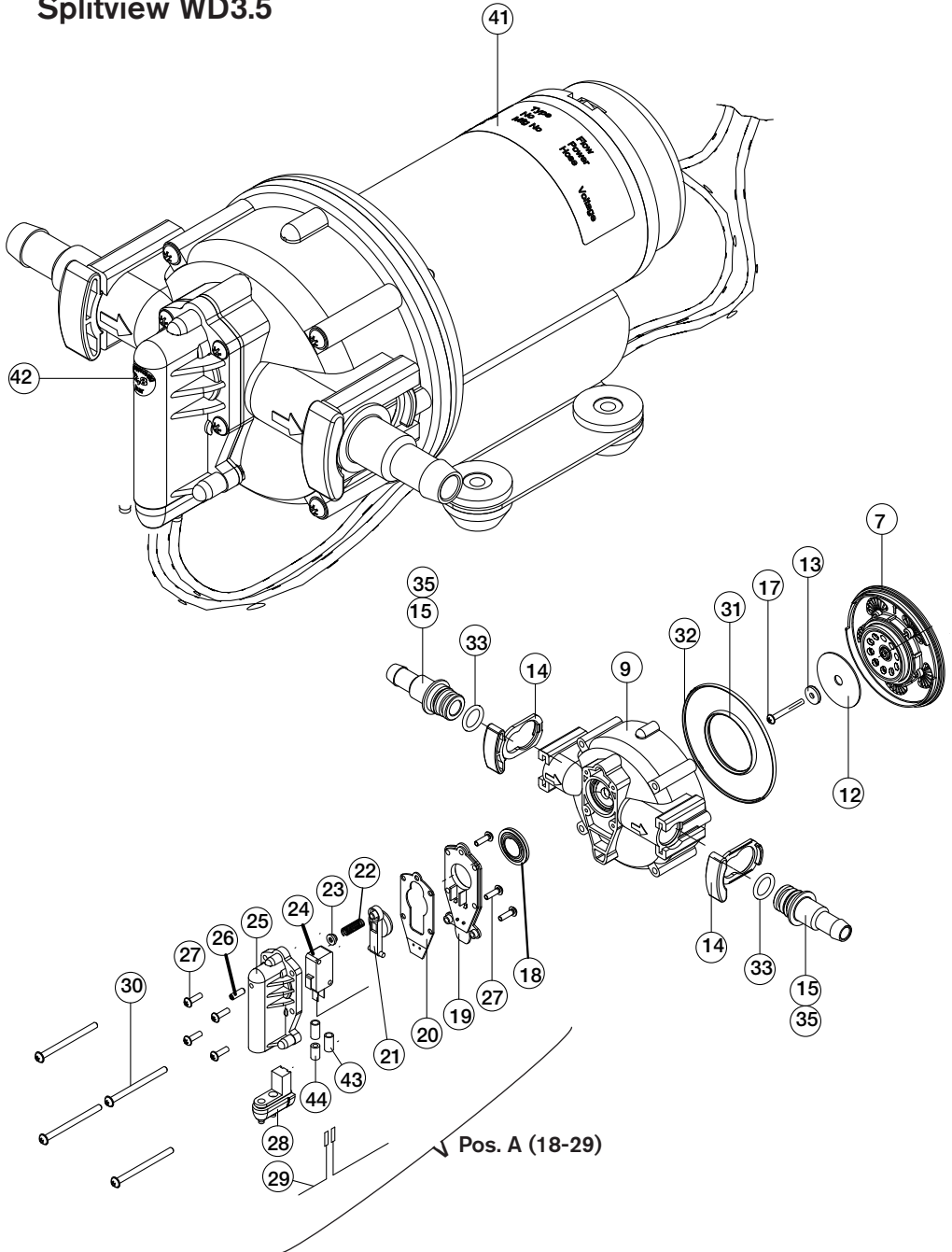

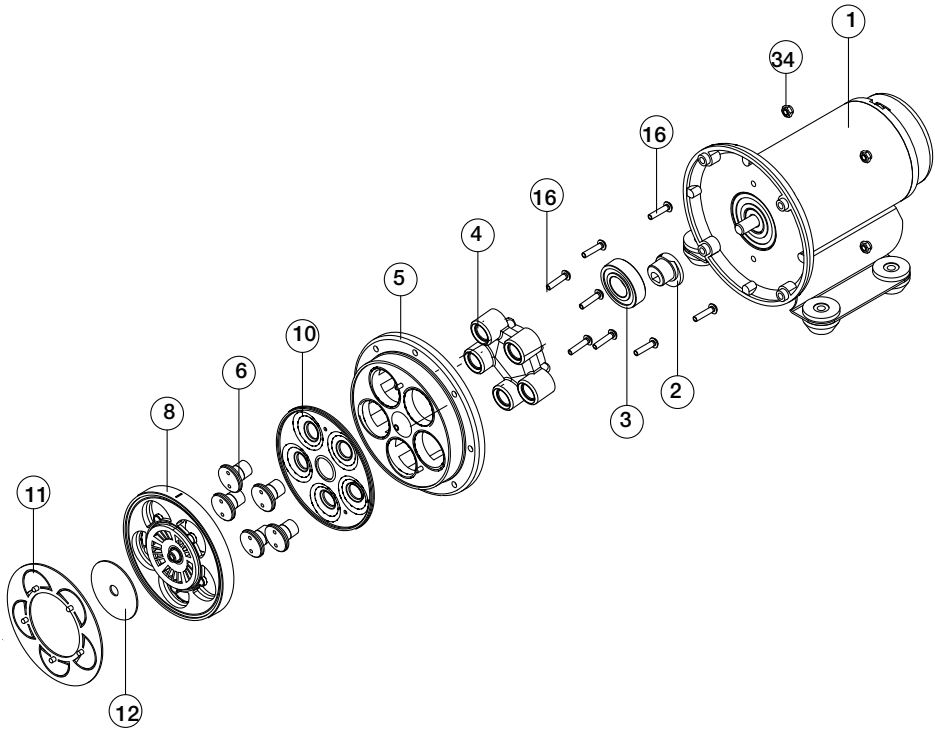

Splitview WD5.2

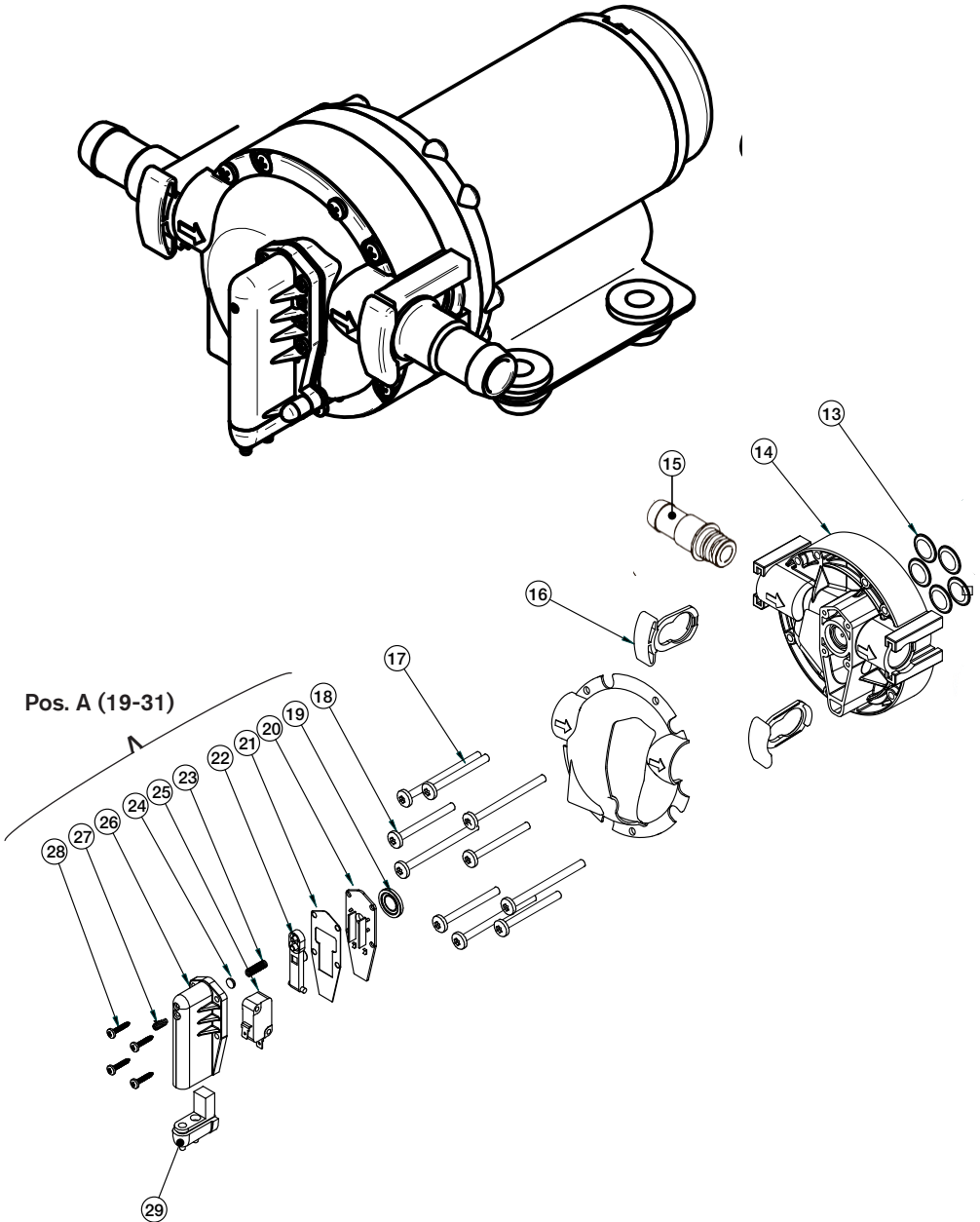

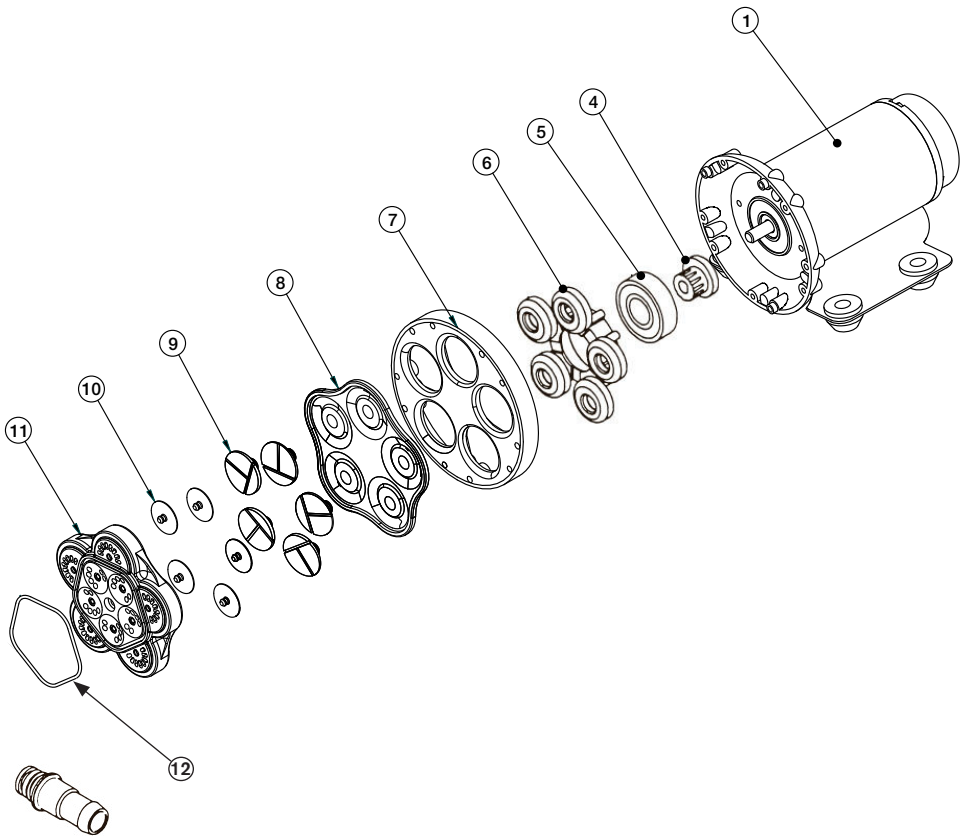

Hole layout 1:1

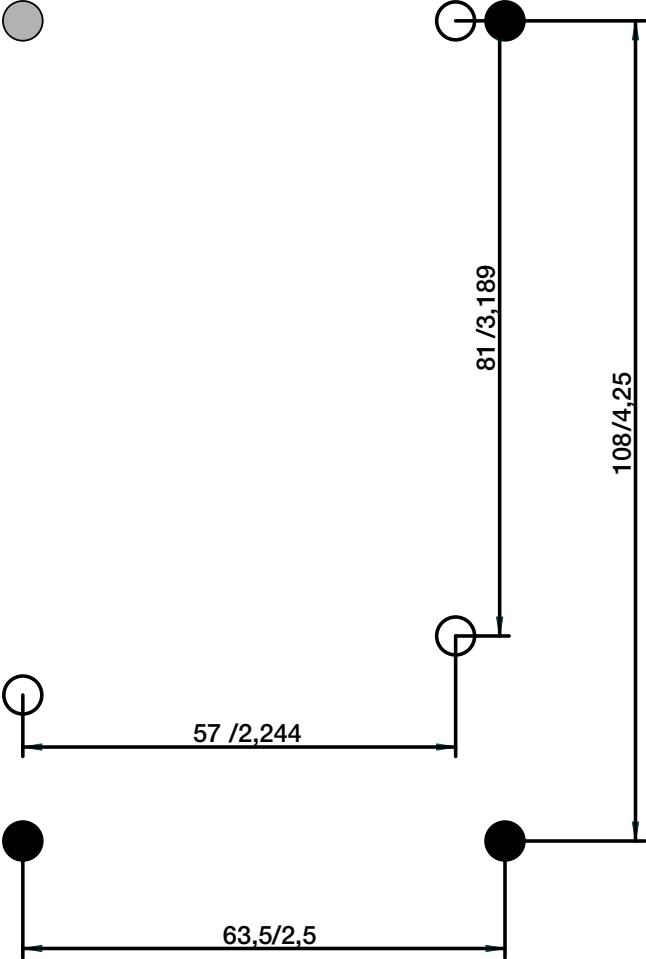

- WD 2.9, WD 3.5 and WD 5.2
- WD 2.9
- WD 3.5 and WD 5.2