

AquaT Marine Toilet

STANDARD ELECTRIC - Comfort, Compact & Super Compact

IB-412-3 R07 (05/2019)

ORIGINAL INSTRUCTIONS/TRANSLATION OF ORIGINAL INSTRUCTIONS
READ AND UNDERSTAND THIS MANUAL PRIOR TO OPERATING OR SERVICING THIS PRODUCT



Comfort



Compact



Super Compact

Marine Toilet, AquaT Standard Electric

Applications

The AquaT Standard Electric marine toilets can be installed in both power and sailing craft, either above or below the water-line, for use on sea, river, lake or canal.

The waste can be discharged either overboard (please have in mind national or local restrictions), or into a treatment system or into an on-board holding tank.

Note: The AquaT Standard electrical toilets are designed specifically for marine use. Consult your SPX FLOW Johnson Pump retailer for advice about possible non-marine applications.

Features

Design

- Silent flush and discharge operation
- Included control panel for rinse and discharge pump
- Flexible hole pattern on the base, for easy substitution with the most common toilets on the market
- Smooth design for easy cleaning
- Accessible mounting points for fast installation
- Standard fastenings, logic located, no need for special tools
- High capacity discharge pump
- Built in rinse pump. For raw water or fresh water from separate toilet water tank. Do not connect the toilets rinse pump to the boats fresh/ drinking water system.

Standard

- Compact, Super Compact or Comfort size bowl

Material

- Plastic seat made of polypropylene
- Hygienic white ceramic bowl for ease of cleaning
- Base molded in ABS or polypropylene, stainless steel fastenings, brass weights and neoprene seals and gaskets

Performance

- Self priming, dry, height 0,6 meters (2ft)
- Discharge height 1,2 meters (4ft)

Control panel

The panel controls the rinse and the discharge, by one button.

- Button 1, One multi function, discharge and rinse.

Dimensions

- Dimensional Drawing on page 6.

Installation instructions, General

Through hull fittings

You need:

19 mm. (3/4") bore seacock for the flushing water inlet, and a 25 mm (1") or 38 mm (1 1/2") bore seacock for the waste outlet.

- Keep to the seacock manufacturer's instructions concerning materials and methods of installation.
- Ensure that the inlet seacock is positioned where it will be below the waterline at all times when the craft is under way and also ensure that any outlet seacock is both aft of, and higher than the inlet seacock.

Pipework - selection of the correct method

You must select the correct installation method for the inlet pipework from 2 possibilities and for the outlet pipework from 4 possibilities, according to whether the toilet is above or below the waterline and to whether it discharges the waste overboard or into an on-board holding tank.

General instructions for all possible Installations

You need/Have in mind:

- Spiral reinforced smooth bore flexible hose for both the 19 mm (3/4") internal diameter inlet and the 25 mm (1") or 38 mm (1 1/2") internal diameter outlet hose.
- Stainless steel hose clips for the hoses.
- Secure the hose runs so that the hoses cannot move, nor exert any leverage action on the hose tail fittings to which they are connected, as this may cause adjacent joints to leak.
- Avoid sharp bends in the hoses since this might cause them to become kinked.
- Keep all pipework lengths as short as possible while you are carrying out these operations. Unnecessary inlet or outlet hose lengths just make the toilet harder to pump.

Tip: Should it be difficult to fit the hose onto the hose tails of the toilet or the sea cocks, soften the hose by dipping its end in hot water.



CAUTION:

- Do not apply flame to hoses
- Do not apply flame or heat to the plastic hose tails of the toilet
- Do not apply sealing compounds to any hose connection
- Secure all hose ends to the hose tails with preferably two stainless steel clips (only one possible on each connection on toilet), ensuring that all inlet connections are airtight and that all outlet connections are watertight.

Pipework

Toilet below the Waterline or below a Holdingtank Inlet

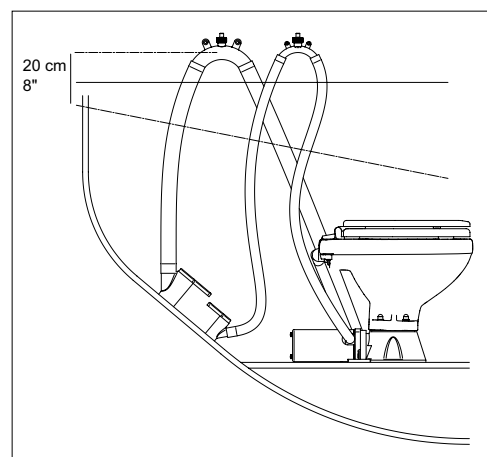

You must use a 19 mm (3/4") Vented Loop fitting.

- The vented loop must be positioned in a way that its point is at least 20 cm (8") above the highest possible waterline.
- Run the inlet hose by the most direct way from the inlet seacock to the vented loop
- Run the inlet hose by the most direct way from the vented loop to toilet flushing pump inlet tail.

Outlet

You must use a 25 mm (1") or 38 mm (1 1/2") Vented Loop fitting

- Arrange the outlet hose, so that its highest point is at least 20 cm (8") above the waterline or holdingtank, and fit the Vented Loop at the highest point.
- Run the outlet hose from the toilet to the vented loop
- Run the outlet hose from the vented loop to the seacock or holdingtank

Toilet above the waterline or above Holdingtank Inlet

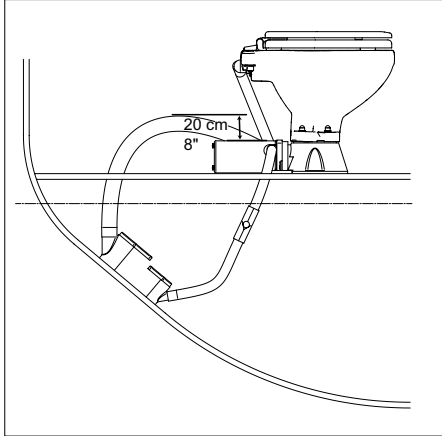

- Run the inlet hose by the most direct route from the inlet seacock to a non return valve.
- Run the inlet hose from the non return valve to the flushing pump inlet tail.
- For your maximum convenience of use, install an in-line non-return valve next to the inlet seacock which will ensure that the pump stays primed in between usages.

Outlet

- As close as possible to the toilet rise the outlet hose 20 cm above the base to retain water in the bowl. Make sure the outlet hose stays in this position.
- Connect outlet hose connection on the toilet to the seacock or holding tank.

Safety

Ensure that these instructions reach the owner, the skipper or the operator of the craft, as it contains important safety information ON COMPLETION OF Installation: Shut the flush control close both seacocks

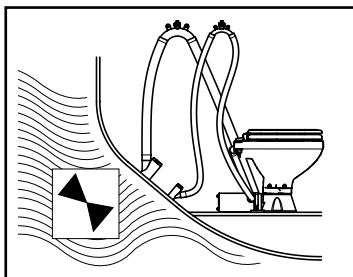
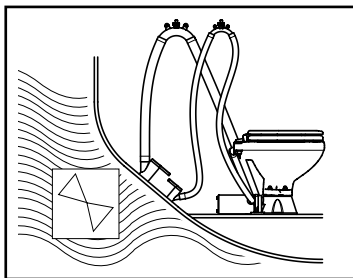

Installation instructions

Introduction

If the installation of the toilet results in being connected to any through-hull fitting that may possibly be below the waterline whether when the craft is at rest, underway, heeling, rolling or pitching, you must install the toilet in accordance with the present installation instructions. Failure to follow such instructions may cause water to flood in, which may result in loss of life.



ACCIDENTAL DAMAGE:

If the toilet is connected to any through-hull fitting and if the toilet or the pipework are damaged, water may flood in, causing the craft to sink with a consequent possible loss of life. For this reason, if you are making connections between the toilet and any throughhull fitting that may be possibly situated below the waterline, fullbore seacocks must be fitted to such hull-fittings, to allow them to be shut off. The seacocks must also be positioned where they are easily accessible to all users of the toilet. If, for any reason, it is not possible to do it, then secondary full-bore marine quality valves must be fitted to the hoses where they are easily accessible.



CAUTION:

Use seacocks! Use lever operated, full-bore marine seacocks and valves. The use of screwdown gate valves is not recommended.

Pipework loosing

All pipeworks must be fastened both in the gate side and in the remaining ones with a stainless steel hose clamp. Please keep in mind that an eventual leak might cause the craft to sink, with consequent loss of life USE HOSE CLAMPS!

Bowl rim below the waterline

If the toilet is connected to any through-hull fitting and if the rim of the bowl falls below the waterline, water may flood in, causing the craft to sink, which may result in loss of life. Therefore, if the rim of the toilet is less than 20 cm (8") above the waterline when the craft is at rest, or if there is any possibility that the rim of the bowl may be below the waterline at any time, a vented loop must be fitted in any pipework connected to a through-hull fitting, irrespective of whether inlet or outlet. USE VENTED LOOPS!

Special notes: Special notes: The smaller bore inlet pipework is more dangerous than the larger outlet one. Unless there is a ventilated anti-siphon loop in the inlet pipework, water will flow into the bowl whenever both the inlet seacock is opened and the rim of the bowl is below the actual waterline. Although moving the flush control lever to the "Shut" position will restrict the flow, this lever cannot be relied upon as a safety device. To make a loop in the hose without mounting a vent may be as hazardous as no loop at all, because water will siphon over the loop. IN FACT, IT IS THE VENT THAT ACTUALLY PREVENTS THE SIPHON

Location

- The mounting surface must be flat, rigid, and strong enough to support a man's weight and should be at least 50 mm (2") wider and 50 mm (2") deeper than the base of the toilet.
- You will need sufficient clearance below the mounting surface to be able to secure the mounting bolts.
- The seat and the lid should be able to swing open at least 110 degrees, in order they will not fall forward when the craft heels or pitches. When they are swung open, they must be supported so that the hinges are not strained.

Mounting

Before starting the assembly, read the complete mounting instruction first.

You need:

- Stainless steel bolts: 4 pcs, 8mm (5/16") diameter of length to suit the thickness of the mounting surface.
- Stainless steel nuts: 4 pcs preferably self-locking. If you do not use self-locking nuts you need to add locking compound on the screws-/ nuts.
- Stainless steel washers: 4 pcs.
- Drill: Diameter 9mm.
- Silicone sealant, white.

If you do not use self-locking nuts, you will need some nutlocking compound

- Put the toilet in the selected position. Using the holes in the base as a guide, mark the positions for the 4 bolt holes on the mounting surface. Remove the toilet and drill 4 vertical holes, with a diameter of 9mm, through the mounting surface.
- Apply the white silicone sealant to the outer rim of the bottom base.
- Put the toilets on its place and tighten the fastenings securely. If you are not using self-locking nuts, use nutlocking compound.
- Use the sealant around the base, towards the floor.

Operating instructions

The toilet is one of the most used pieces of equipment on your boat. Correct operation of the toilet is essential for the safety and comfort of your crew and craft.

Using the toilet

Control panel

The panel controls the rinse and the discharge, by one button.

- Button 1: One function, discharge and rinse.



Normal Use

- Ensure that the inlet and outlet valves are open
 - Push the button switch to operate flush until the bowl is thoroughly rinsed and the discharge pump has ejected the water from the base of the bowl.
- If the toilet has not been used for a while, and the bowl is dry, it's recommended to operate the pumps for a few seconds so the bowl gets wet. This is for preventing the toilet paper to become compact at the bottom of the bowl.
 - The toilet can macerate organic waste and toilet paper, but it can not destroy rugs, sanitary nappies or hard and solid objects from different nature
 - If the pump does not discharge and the bowl begins to fill, partially close the toilet intake valve until the bowl is completely empty. Operate than for a few seconds with both valves open, so that the toilet and the whole discharge system may be completely emptied out.
 - After each operation, close both inlet and discharge valves.
 - To drain for winterization, close the inlet valve and operate for a few seconds until water is completely empty.

After use:

- Shut both seacocks

NOTE: Do not put any of the following into the toilet: Sanitary Towels, Wet Strength Tissues, Cotton Wool, Cigarettes, Matches, Chewing Gum or any solid objects, Petrol, Diesel, Oil, Solvents of any kind or water more than hand warm.

A rule of thumb: Do not put anything in the toilet unless it has passed through your body, except for toilet paper.



Hazard Risk:

ACCIDENTAL DAMAGE. If the toilet is connected to ANY through-hull fittings that are below the waterline at any time, and if the toilet or pipework is damaged, water may flood in, causing the craft to sink, which may result in loss of life. Therefore, after every usage; both seacocks (or secondary valves) **MUST** be shut. Whenever your craft is unattended, even if only for a very short period of time, both seacocks (even if secondary valves are fitted) **MUST** be shut. Ensure that ALL users understand how to operate the toilet system correctly and safely, including seacocks and secondary valves. Take special care to instruct children, the elderly and visitors **ABSOLUTELY SHUT SEACOCKS!**

Cleaning

A regular flushing with clean (sea)-water represents one of the most effective methods to keep the toilet clean and good smelling.

- To clean the bowl, use any liquid or cream ceramic cleaner
- To clean the rest of the toilet, including the seat and lid, use a non-abrasive liquid cleaner Polish with a dry cloth only.
- To disinfect the toilet, use a liquid disinfectant diluted in accordance with the manufacturer's instructions. It is possible to apply it to all parts of the toilet using a sponge or soft brush as necessary.
- After applying any cleaning or disinfecting agent, always flush well. **DO NOT ALLOW THESE AGENTS TO STAND IN THE SYSTEM**

Electric Connections

Connect the wires from the pump as follows:

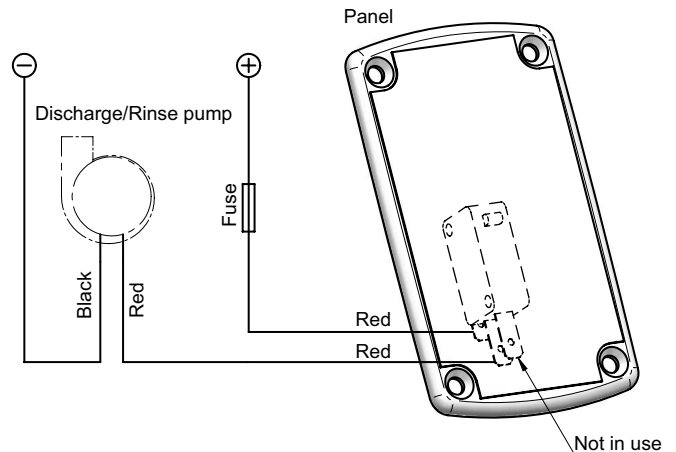

Panel Red (upper wire on switch) to positive (+) battery via one fuse

Panel Red (lower wire on switch) to toilet pump red

Toilet pump Black to battery negative (-)

To install the switch panel, use the template or dimensions from the template. Also, drill four appropriate sized holes for the fasteners selected to secure the switch panel to its mounting surface. Use the enclosed template, see page 27.

Wire size per feet and meter of run						
Voltage	Fuse size	0'-10'	10'-15'	15'-25'	25'-40'	40'-60'
		0m-3m	3m-4,6m	4,6m-7,6m	7,6m-12,2m	12,2m-18,3m
12V	25A	#14	#14	#12	#10	#8
		2,5 mm ²	2,5 mm ²	4 mm ²	6 mm ²	10 mm ²
24V	20A	#14	#14	#14	#14	#12
		2,5 mm ²	2,5 mm ²	2,5 mm ²	2,5 mm ²	4 mm ²

Dimensions

Part No.	Description	Net weight		A	B	C	D	E	mm/ inch
80-47626-01	AquaT Standard Electric Super Compact, 12V	9,2	kg	340	635	330	450	215	mm
80-47626-02	AquaT Standard Electric Super Compact, 24V	20	lbs	13,39	25,00	12,99	17,72	8,46	inch
80-47435-01	AquaT Standard Electric Compact, 12V	9,5	kg	340	680	380	450	215	mm
80-47435-02	AquaT Standard Electric Compact, 24V	21	lbs	13,39	26,77	14,96	17,72	8,46	inch
80-47436-01	AquaT Standard Electric Comfort, 12V	11	kg	365	755	360	475	260	mm
80-47436-02	AquaT Standard Electric Comfort, 24V	24	lbs	14,37	29,72	14,17	18,70	10,24	inch

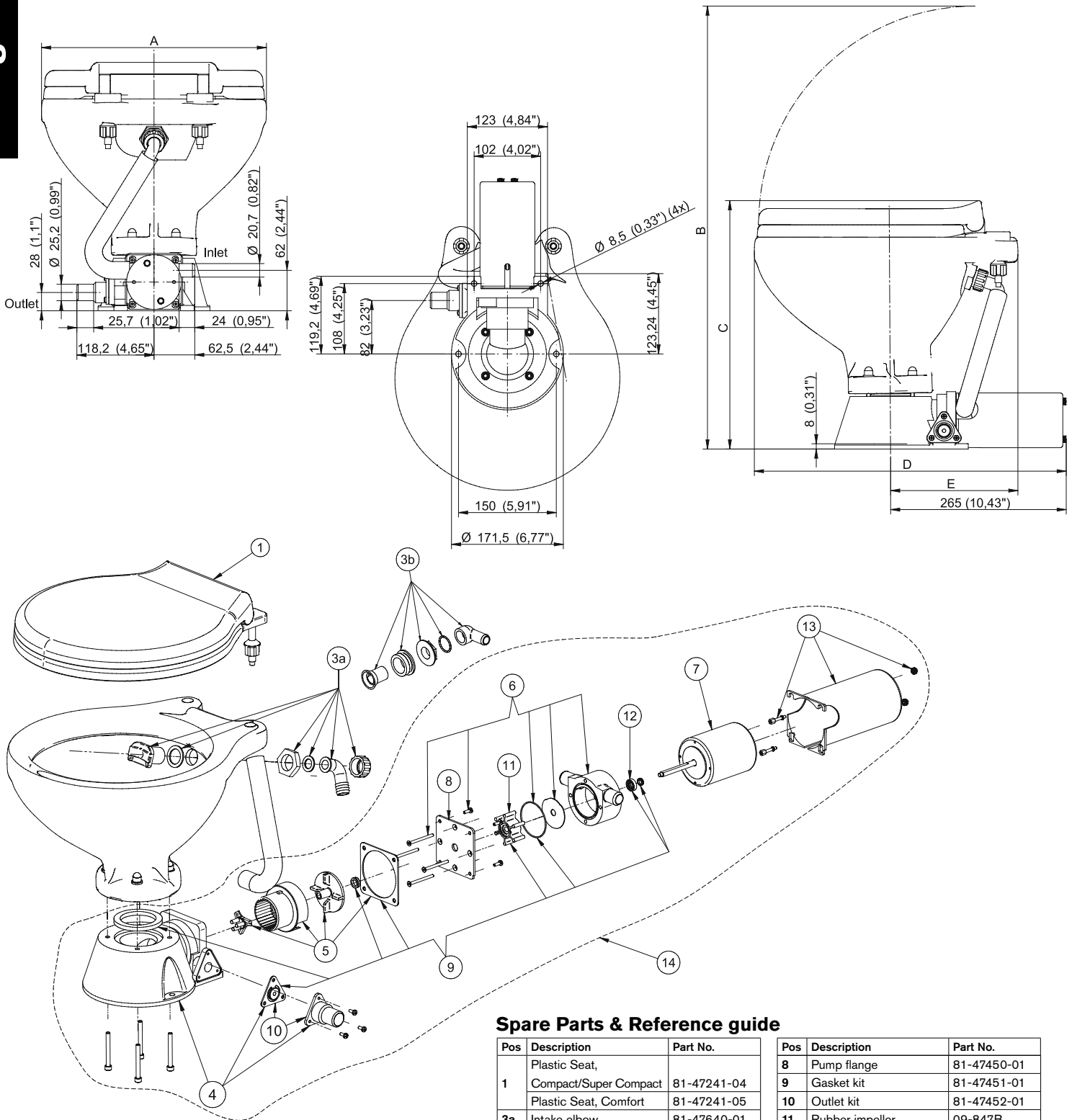

Spare Parts & Reference guide

Pos	Description	Part No.	Pos	Description	Part No.
1	Plastic Seat, Compact/Super Compact	81-47241-04	8	Pump flange	81-47450-01
	Plastic Seat, Comfort	81-47241-05	9	Gasket kit	81-47451-01
3a	Intake elbow	81-47640-01	10	Outlet kit	81-47452-01
3b	Intake elbow	81-47246-01	11	Rubber impeller	09-847B
4	Base group	81-47446-01	12	Seal	81-47453-01
5	Macerator group	81-47447-01	13	Motor cover	81-47443-01
6	Pump group	81-47448-01	14	Conversion kit pump assembly 12V	81-47442-01
7	Motor group 12V	81-47449-01		Conversion kit pump assembly 24V	81-47442-02
	Motor group 24V	81-47449-02			

Panel Template

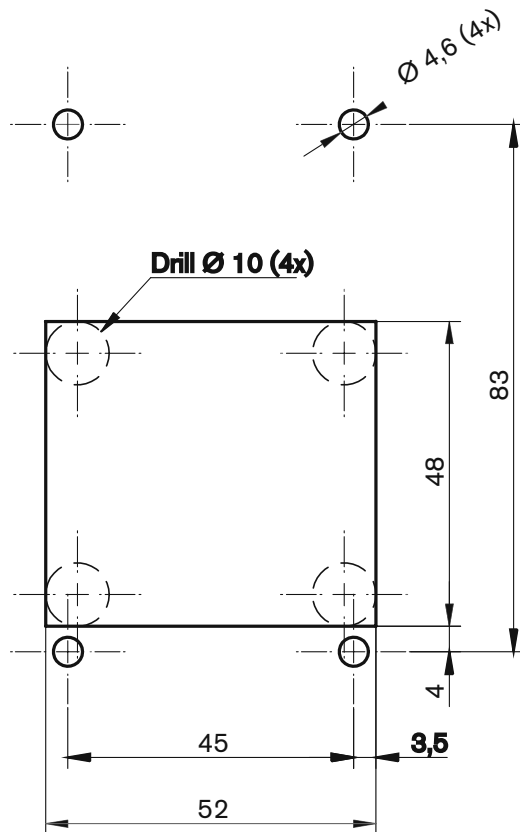

- Drill 4 appropriate sized holes for the fasteners selected to secure the switch panel to its mounting surface.

(Note: not in scale)

EN: Waste handling & material recycling

At the products end of life, please dispose of the product according to applicable law. Where applicable, please disassemble the product and recycle the parts material.