

KXM
AMPLIFIERS
Owner's Manual

KXMA1200.1

MODEL:

KXMA1200.1

IMPORTANT SAFETY WARNING

PROLONGED CONTINUOUS OPERATION OF AN AMPLIFIER, SPEAKER, OR SUBWOOFER IN A DISTORTED, CLIPPED OR OVER-POWERED MANNER CAN CAUSE YOUR AUDIO SYSTEM TO OVERHEAT, POSSIBLY CATCHING FIRE AND RESULTING IN SERIOUS DAMAGE TO YOUR COMPONENTS AND/OR VEHICLE. AMPLIFIERS REQUIRE UP TO 4 INCHES (10CM) OPEN VENTILATION. SUBWOOFERS SHOULD BE MOUNTED WITH AT LEAST 1 INCH (2.5CM) CLEARANCE BETWEEN THE FRONT OF THE SPEAKER AND ANY SURFACE.

PERFORMANCE

Model:	KXMA1200.1
RMS Power	
@ 14.4V, 4Ω mono, ≤ 1% THD+N	600W x 1
@ 14.4V, 2Ω mono, ≤ 1% THD+N	1200W x 1
Length [in, cm]	9-9/16, 24.4
Height [in, cm]	2 1/8, 5.5
Width [in, cm]	8 5/16, 21
Frequency Response ± 1dB	10Hz–160Hz
Signal-to-noise Ratio	>95dB, A-weighted, re: rated power
Input Sensitivity	250mV–10V
Selectable Electronic Crossover	Variable Lo-pass 40Hz–160Hz, 24dB/octave
KickEQ+™ Parametric Bass Boost	Boost - Variable 0–18db; Center Frequency - 20Hz–80Hz; Bandwidth 1–5
Subsonic Filter	Variable 10–80Hz, 24dB/octave

NOTE: 2017 KXM amplifier subwoofer channels are 1Ω stable - power rating equivalent to 2Ω operation, +/- 10%

INSTALLATION

Mounting: Choose a dry, structurally sound location to mount your KICKER amplifier. Make sure there are no items behind the area where the screws will be driven. Choose a location that allows at least 4" (10cm) of open ventilation for the amplifier. Drill four holes using a 7/64" (3mm) bit and use the supplied #8 screws to mount the amplifier.

Wiring: The KXM amplifier's RCA inputs will receive either high or low level signals from your car stereo's source unit. A high-level signal can be run from the source unit's speaker outputs to the stereo RCA input on the end panel of the amplifier using the KICKER KISL as shown. Alternatively, the signal can be delivered to the amplifier using the low-level RCA outputs on the source unit. Keep the audio signal cable away from factory wiring harnesses and other power wiring. If you need to cross this wiring, cross it at a 90 degree angle.

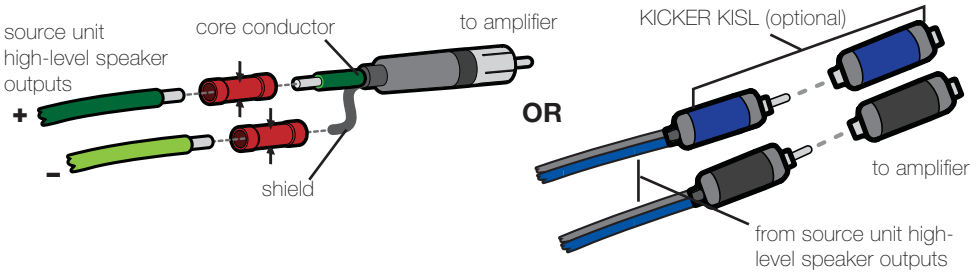

Install a fuse within 7" (18cm) of the battery and in-line with the power cable connected to your amplifier.

Model	External Fuse (sold separately)	Power/Ground Wire	KICKER Wiring Kit
KXMA1200.1 1 x 150 Ampere	4 Gauge	4 Gauge	PK4, CK4

MONO OPERATION minimum impedance of 1 ohm

Amplifier uses 304-stainless steel screws and conformal coated PCB for increased weather resistance

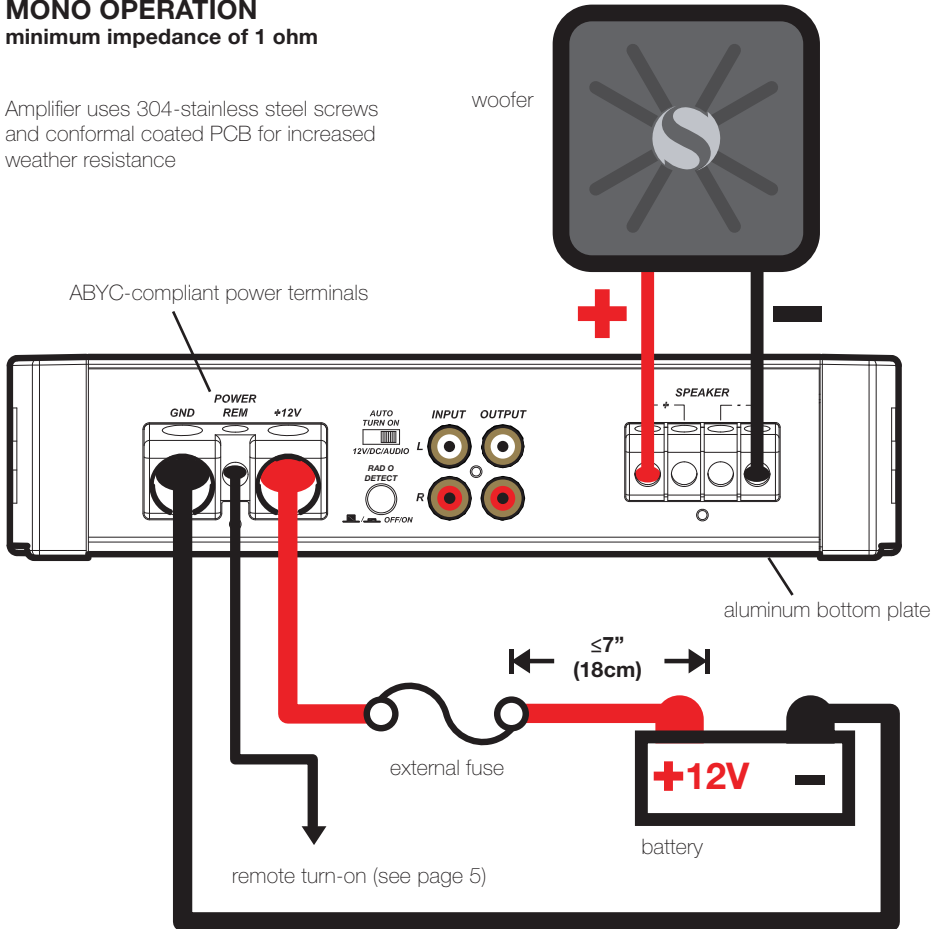

For multiple amplifier installations where distribution blocks are used, each amplifier should have its proper-rated fuse, or breaker, installed between the amplifier and the distribution block within seven inches of the block, or on the distribution block if it provides for fusing. The primary power wire should also be fused between the battery and distribution block, within seven inches of the battery's B+ terminal, with a fuse or breaker rated at least to the sum of the individual amplifier's fuse values, but not to exceed 1.5-times the sum of the individual fuse values (not to exceed the ampacity of the thermal insulation of the wiring as shown in U.S.C.G. CFR33 183.425, Table 5). See the diagram below.

NOTE: Seven inches is the standard distance under U.S. Coast Guard CFR33 for placement of fuses or breakers as required by law for new boat manufacturing. We recommend trying to adhere to this standard in a consumer installation. Failure to do so does not mean you are breaking the law, but it does put the safety of your boat and passengers at risk in the event of a power wire short circuit.

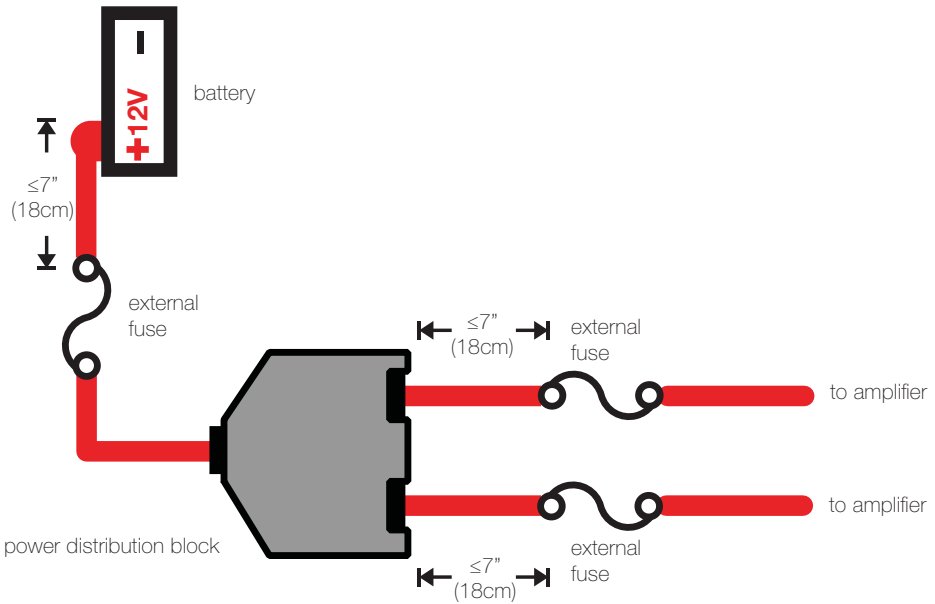

KICKER will now provide a three-year warranty with all KXA-Series Amplifier purchases paired with a qualifying KICKER Installation Kit* .

This extends the standard warranty by an additional year. Amplifier and Kit must be purchased from an **Authorized KICKER Dealer**.

KICKER KXM amplifier success is currently at an unheard-of rate, making the extended warranty program even more beneficial to you.

Using poor-quality, under-spec wiring kits will impede KXM amplifier performance.

A superior-quality KICKER installation Kit is guaranteed to extend the life of KXM amplifiers.

The new extended warranty applies only to KICKER amplifiers and accessories sold to consumers by Authorized KICKER Dealers in the United States of America or its possessions. It also only applies to the original purchaser of KICKER amplifiers and accessories. One warranty extension per amplifier is allowed regardless of the number of amplifier installation kits purchased. This program does not apply to "B"-stock product or factory-refurbished product.

This offer is for a limited time, so see your local Authorized KICKER Dealer soon for details.

***U.S.A. Only | EE.UU. solamente | Nur USA | Les USA Seulement**

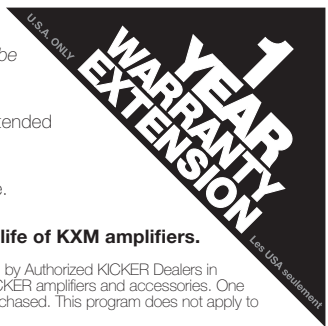

OPERATION

Mini-USB for internal use only; do NOT remove or tamper. KICKER is not responsible for any damage to equipment resulting from connections made to this port.

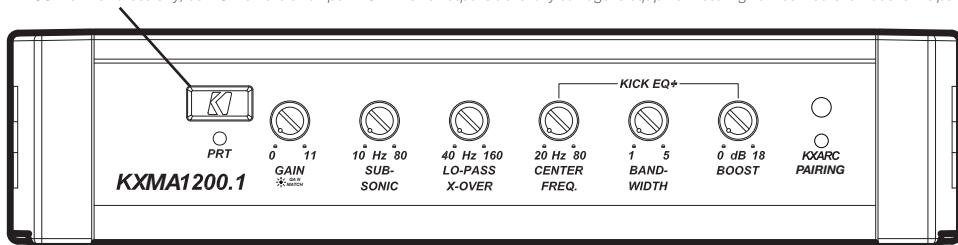

Automatic Turn-On Selection: The KXM series offers three different automatic turn-on modes that can be selected on the end panel; +12V, DC Offset, and Audio. Using either the DC Offset or Audio mode causes the REM terminal to have +12V out for turning on additional amplifiers.

- Remote Turn-On: Set the switch to +12V to use the remote turn-on lead from your source unit. Run 18 gauge wire from the Remote Turn-On Lead on your source unit to the terminal labeled REM between the amplifier's positive and negative power terminals. This is the preferred automatic turn-on method.
- DC Offset Turn-On: If Remote Turn-On is not an option, the next best setting is DC Offset. The DC Offset mode detects a 3V DC offset from the HI-Level speaker outputs when the source unit has been turned on.
- Signal Sense Turn-On: The Audio setting is the final alternative for Automatic turn-on. This is a Signal Sense turn-on method that detects the incoming audio signal from your source unit and automatically turns on the amp. This turn-on method will not work properly if the input gain control is not set appropriately.

Radio Detect: The RCA inputs on KICKER KXM amplifiers are capable of receiving either Hi or Low-level signals from your source unit. If you are using Hi-Level inputs, but your source unit cannot detect an audio system present or refuses to play audio out of one or more speakers, you may need to set Radio Detect to ON. This will activate a load resistor at the amplifier's inputs and tell the source unit there are speakers present. Do NOT use Radio Detect if you are using a Low-Level input signal; doing so will greatly reduce the input signal.

Input Gain Control with Gain Matching: The input gain control is not a volume control. It matches the output of the source unit to the input level of the amplifier and features Gain Matching to prevent clipping the input. For a quick setup, turn the source unit up to about 3/4 volume (if the source unit goes to 30, turn it to 25). KICKER recommends using the test tones to reach the most accurate and best performing settings. Next, slowly turn (clockwise) the gain on the amplifier up until you see the Gain LED light up or hear audible distortion, then turn it down a little. If the GAIN knob's backlight comes on, the input is still clipping. For full instructions on Gain Matching, please see the next page.

Adjustable Subsonic Filter: The variable subsonic filter will provide a cut-off point for lower frequencies (10–80Hz) that could potentially damage your speakers from over-excursion, along with wasting your amplifier's power. The setting for this control should be set relative to your speaker's low-frequency capability. The setting for this control should be set relative to your speaker's low-frequency capability, and is recommended for ported enclosures.

Crossover Control: The variable crossover on the amplifier is always active, and allows you to adjust the LO-PASS crossover frequency from 40–160Hz. The setting for this control is subjective; 80Hz is a good place to start.

KICK EQ+ Bass Boost Control: The variable bass boost control on the side of the amplifier is designed to give you increased output, 0–18dB, at the selected frequency. A higher BANDWIDTH (Q) setting will result in a sharper cut at the frequencies above and below the selected center frequency. The setting for this control is subjective. If you turn it up, you must readjust the input gain control to avoid clipping the amplifier.

Remote Control-KXARC: With the included KXARC remote control, you have the ability to unlock and control DSP functions of the amplifier remotely. 2017 and newer KXM amplifiers. See page 7 for installation.

KXARC Pairing: Use the pairing button located above the pairing LED to put the KXM amplifier into pairing mode. The light will flash when the amp is in pairing mode and ready to connect to a KXARC remote; once connected it will remain solid. Press and hold the pairing button to clear the list of devices.

GAIN MATCHING

In any audio system, the goal is to reach maximum input and output levels without distortion or clipping. The engineers at KICKER have taken the guesswork, and hassle, out of matching the output voltage of your source unit to the amplifier with the Gain Matching feature.

1kHz @ 0dBFS, 50Hz @ 0dBFS, 1kHz @ -10dBFS, 50Hz @ -10dBFS, 1kHz @ -5dBFS, 50Hz @ -5dBFS

These test tones are sine waves meant to provide a consistent signal for the KX amplifier to reference. The different recording levels are designed to give you the perfect gain match for your application.

0dBFS: Designed for audiophile applications to give you distortion free audio output with the most dynamic range.

-5dBFS: Designed for normal/daily applications, there will be less dynamic range but higher potential audio output levels. With this set up you can get some occasional clipping from the amplifier.

-10dBFS: Designed only for Subwoofer applications, there will be less dynamic range but higher potential audio output levels. With this set up you can get some clipping from the amplifier.

Afterwards, use the following procedure to accurately Gain Match your amplifier(s):

1. Disconnect the speakers from the KX amplifier.
2. Set all EQ and crossover settings to flat on your source unit.
3. Play the downloadable file from KICKER.
4. Turn the source unit up to 3/4 volume.
5. Increase the gain of the amplifier until the Gain LED turns on.
6. Decrease the gain of the amplifier until the Gain LED turns off.



All level matching circuitry in the KX amplifiers is at the beginning of the signal chain. If you are going to use features like bass boost, SHOCwave or EQ settings, it may be necessary to readjust the gain to a lower setting to compensate for increased output at those frequencies.

Once the amp and source unit are gain matched, you will want to make certain you are not overdriving your speakers. Use the following procedure:

1. Set the source until volume to 0.
2. Reconnect the speakers to the KX amplifier.
3. Slowly increase the volume level of the source unit as you listen for audible distortion.
4. If you can hear clipping, decrease the gain of the amplifier until it is gone.

Likewise, you can use the CLIP indicator feature of the KXARC remote to easily identify which amplifier's output is clipping and when.

KXARC REMOTE INSTALLATION

FLUSH MOUNTING

mounting depth: 3/4" [19.5mm]

mounting dimensions: 3 3/4" [99mm] x 2 1/8" [55mm]

Secure the Mounting Brackets, Bezel, and Surface Mount Cup to the desired location using the included screws.

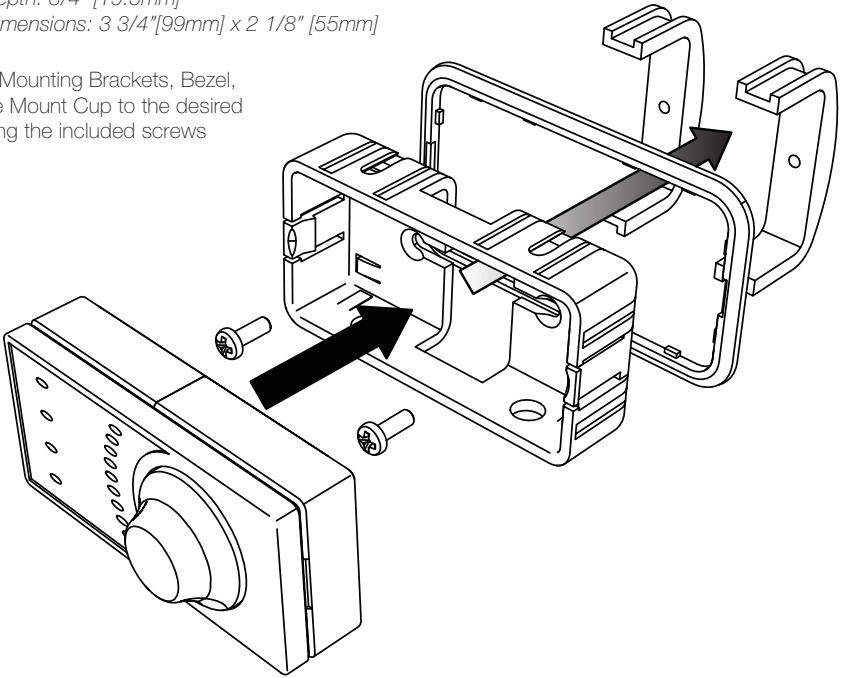

SURFACE MOUNTING

Secure the Surface Mount Cup to the desired location using the included screws.

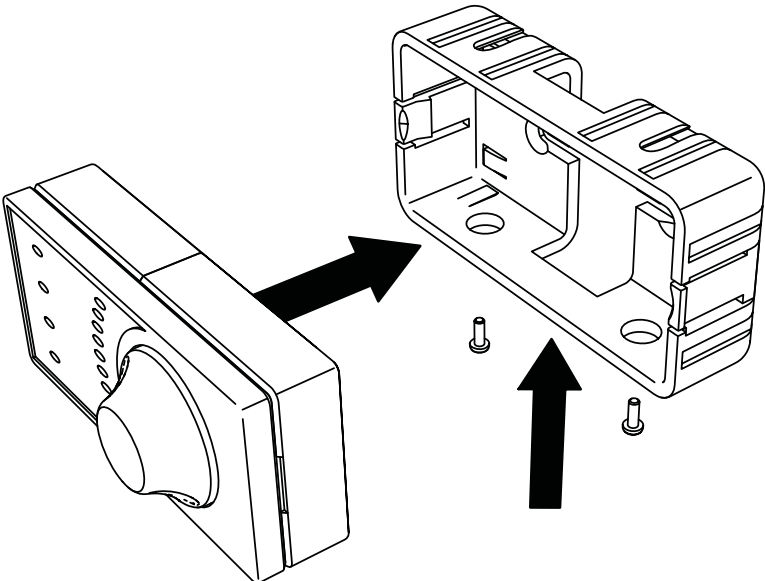

REPLACING THE BATTERY

model: CR2450 (3V)

On the back of the KXARC, slide the battery cover off in the manner shown. This will expose the battery holder.

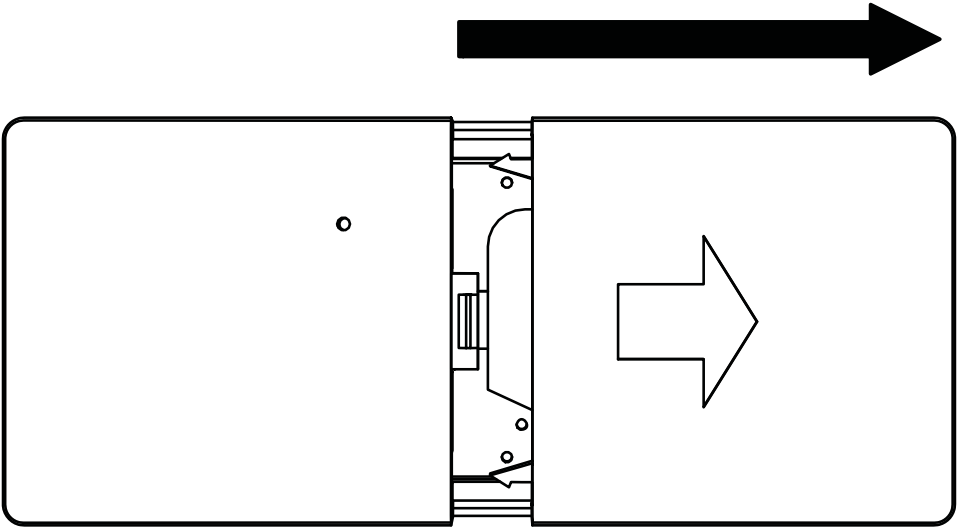

Slide the battery out of the batter holder from the top. Replace the battery and battery cover in the same manner in which they were removed. Make sure the battery isn't upside down when placed in the battery holder. Positive is toward the top of the battery holder.

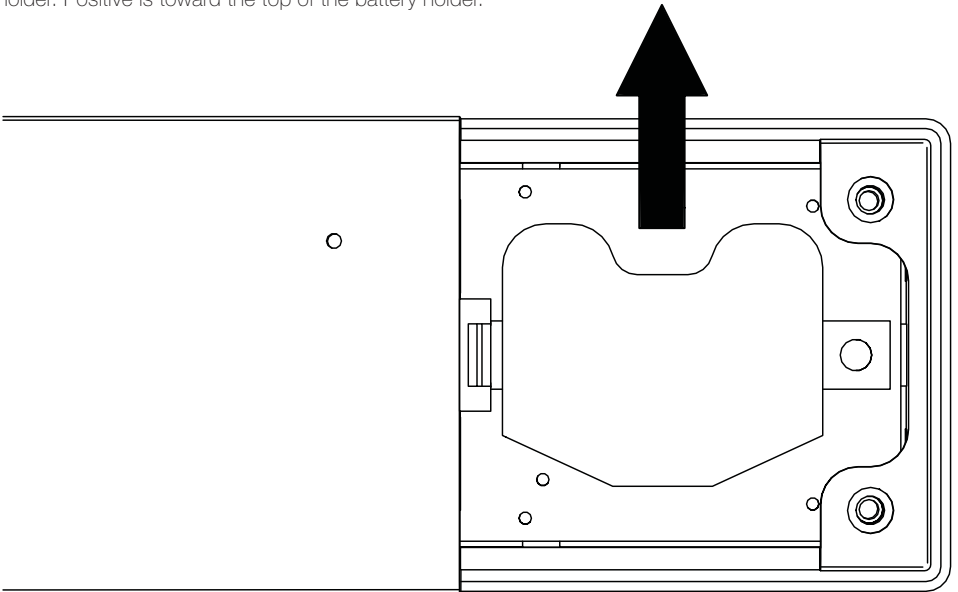

KXARC REMOTE OPERATION

BLUETOOTH® PAIRING

To place the KXARC in pairing mode, insert a pin, paperclip or other available skinny, pointy object into the inconspicuous little hole on the back of the remote and press for 1 second. If the KXMA amplifier is also in pairing mode, the devices will connect. Your KXARC will stay in pairing mode to connect to the next amp.

Pairing button

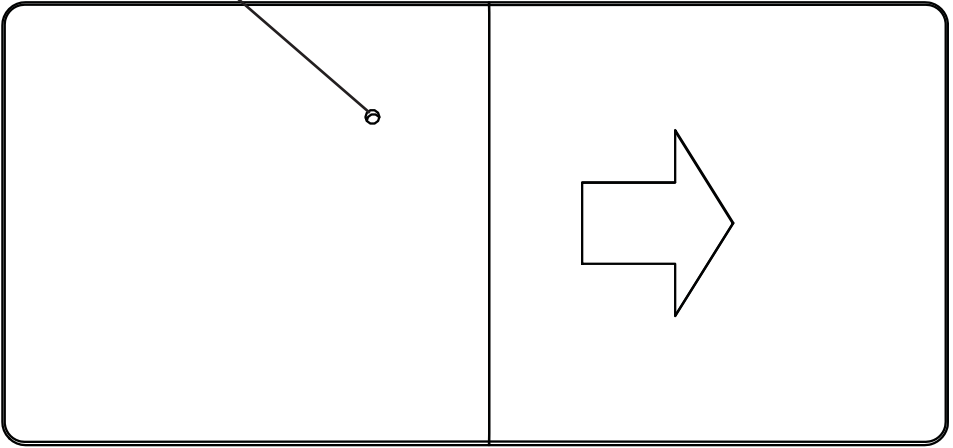

Pairing mode will time out after 30 seconds, or you may press the pairing button again. You may pair up to 4 KXMA amplifiers that feature a subwoofer channel (mono or 5-channel models). The KXARC keeps track of each amp and denotes the current amp selected with the bottom 4 status LEDs.

Press & hold to enter LED brightness adjustment.

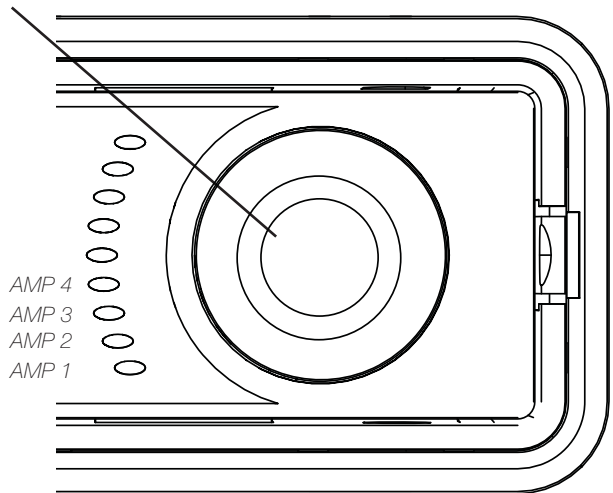

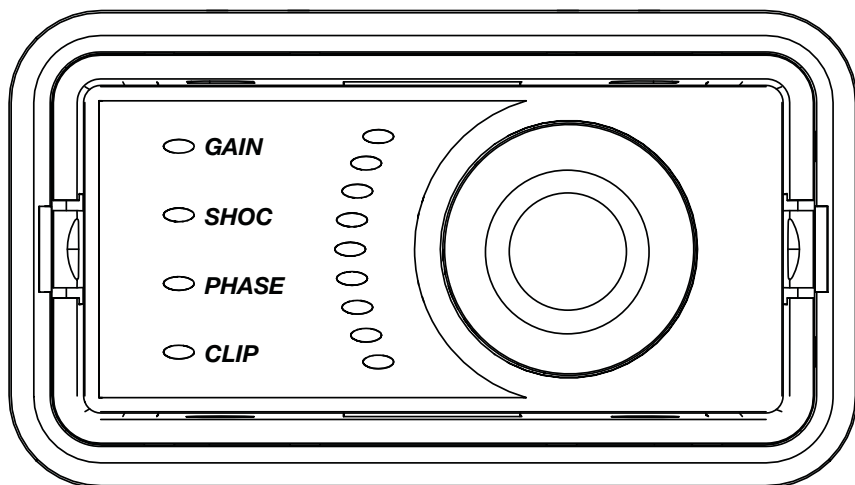

Press the KXARC knob to cycle through GAIN, SHOC, PHASE, and CLIP settings, then rotate the knob to adjust the corresponding values. The KXARC supports up to 4 KICKER KXMA amplifiers featuring a subwoofer channel.

Gain: The KXARC gain control is a gain attenuator from -26dB to 0dB. This will allow you to conveniently adjust the gain of the subwoofer channel on the fly, with the maximum being the gain setting you've selected on the KXM amplifier side panel.

SHOCwave: The SHOCwave (Sub Harmonic Octave Creation) will restore low frequencies that are weaker in older recordings or lost in data compression. The SUBWOOFER channel must be operating with a full-range signal for this effect to work properly. Press the knob until SHOC is illuminated, then adjust the knob to a level that is satisfactory.

Phase: The PHASE setting allows you to select the phasing of the subwoofer frequency; 0°, or 180°. If you are experiencing an absence of bass in the audio, the bass frequency may be out of phase with the rest of the system. Delay, reversing positive/negative polarity, or changing subwoofer location may also resolve these types of issues. The top LEDs will indicate 0°, while the bottom will indicate 180°.

Clip: The CLIP indicator will illuminate the LED corresponding to an amplifier with a clipped output signal when CLIP is selected. Simply press the KXARC knob until CLIP is selected, then watch the bottom 4 LEDs to see which amplifier is clipping and at what time. If CLIP is not selected, the CLIP LED will act as a global clip indicator. If you change your Gain or SHOCwave setting, you may notice the CLIP LED become active. This means your new DSP settings have caused an output to clip and you should reduce the gain or compensate in some other way.

TROUBLESHOOTING

If your amplifier does not appear to be working, check the obvious things first such as blown fuses, poor or incorrect wiring connections, incorrect setting of crossover switch and gain controls, etc. There is a Protection (PRT) LED on the side panel of your Kicker KXM series amplifier. Depending on the state of the amplifier and the vehicle's charging system, the LED will either glow red or be off.

Red (PRT) LED flickering with loud music? The red (PRT) LED indicates low battery voltage. Check all the connections in your vehicle's charging system. It may be necessary to replace or charge your vehicle's battery or replace your vehicle's alternator.

Red (PRT) LED on, no output? ❶ Amplifier is very hot = thermal protection is engaged. Test for proper impedance at the speaker terminals with a VOM meter (see the diagrams in this manual for minimum recommended impedance and multiple speaker wiring suggestions). Also check for adequate airflow around the amplifier. ❷ Amplifier shuts down only while vehicle is running = voltage protection circuitry is engaged. Voltage to the amplifier is not within the 10–16 volt operating range. Have the vehicle's charging and electrical system inspected. ❸ Amplifier will only play at low volume levels = short circuit protection is engaged. Check for speaker wires shorted to each other or to the vehicle chassis. Check for damaged speakers or speaker(s) operating below the minimum recommended impedance.

No or low output? ❶ Check the balance control on source unit ❷ Check the RCA (or speaker input) and speaker output connections.

Alternator noise-whining sound with engine's RPM? ❶ Check for damaged RCA (or speaker input) cable ❷ Check the routing of RCA (or speaker input) cable ❸ Check the source unit for proper grounding ❹ Check the gain settings and turn them down if they are set too high.

Ground Noise? KICKER amplifiers are engineered to be fully compatible with all manufacturers' head units. Some head units may require additional grounding to prevent noise from entering the audio signal. If you are experiencing this problem with your head unit, in most cases running a ground wire from the RCA outputs on the head unit to the chassis will remedy this issue.

KXARC Troubleshooting: If the KXARC LEDs flash three times, it is not currently connected to an amp. Press the pairing button on the back of the remote and on the KXMA amp for 1 second. *NOTE:* If the KXARC is not active or in sleep mode, it will not show as connected on the KXMA panel. If the KXARC will not power on, replace the battery.

CAUTION: When jump starting the vehicle, be sure that connections made with jumper cables are correct. Improper connections can result in blown amplifier fuses as well as the failure of other critical systems in the vehicle.



KXMA1200.1

600 x 1 @ 4 ohm, 14.4VDC, 1% THD, CEA-2006B (Watts)
Signal to Noise Ratio -75dB CEA-2006B (ref: 1W, A-weighted)