

KM

Subwoofers
Owner's Manual

KM10 | KM12
KMF10 | KMF12

IMPORTANT SAFETY WARNING

PROLONGED CONTINUOUS OPERATION OF AN AMPLIFIER, SPEAKER, OR SUBWOOFER IN A DISTORTED, CLIPPED OR OVER-POWERED MANNER CAN CAUSE YOUR AUDIO SYSTEM TO OVERHEAT, POSSIBLY CATCHING FIRE AND RESULTING IN SERIOUS DAMAGE TO YOUR COMPONENTS AND/OR VEHICLE. AMPLIFIERS REQUIRE UP TO 4 INCHES (10CM) OPEN VENTILATION. SUBWOOFERS SHOULD BE MOUNTED WITH AT LEAST 1 INCH (2.5CM) CLEARANCE BETWEEN THE FRONT OF THE SPEAKER AND ANY SURFACE.

MODEL:	KM10	KMF10	KM12	KMF12
Rated Impedance [Ω]	2 or 4	2 or 4	2 or 4	2 or 4
Fs [Hz]	28.7	46.8	29.9	47.5
Sensitivity [1W, 1m]	86.24	86.27	88.1	87.46
Qts	0.419	0.655	0.47	0.744
Qms	16.699	9.457	15.331	11.044
Qes	0.43	0.704	0.485	0.798
Re [4Ω]	3.64	3.62	3.68	3.63
Vas [ft ³ , L]	1.54, 43.75	.58, 16.540	2.36, 66.96	.83, 23.542
Xmax (Linear Excursion) [mm]	10.3	10.3	10.3	10.3
Continuous Power Handling [Watts RMS]	175	175	175	175
Outer Woofer Dimension [in, cm]	10-11/16, 27.1	10-11/16, 27.1	12-9/16, 31.9	12-9/16, 31.9
Mounting Depth [in, cm]	5, 12.7	5, 12.7	5 1/2, 14	5 1/2, 14
Mounting Cutout Hole Diameter [in, cm]	9-1/4, 23.5	9-1/4, 23.5	11, 28	11, 28
Frequency Response [Hz]	30 - 500	30 - 500	30 - 500	30 - 500

INSTALLATION

Wiring: Carefully place the speaker wire in a location that is clear of standing water and moving components of the boat. The terminal cover is removable for wiring installation and, when locked in place, it aids in ignition protection. Connect the speaker wire to the speaker terminals. Loop the positive and negative wires into the pocket in the cover, then together and through the slot.

Remove Terminal Cover

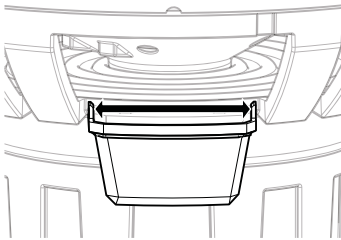

Connect wire to terminals

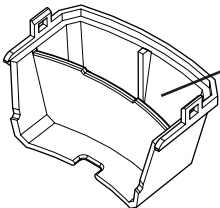
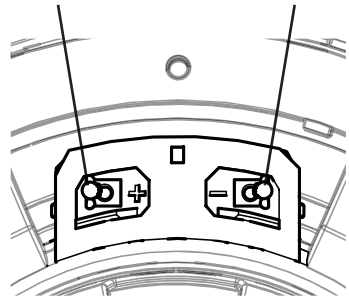

Terminal Cover Pocket

Route wire through Terminal Cover Slot

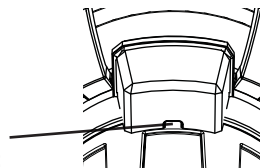

Free Air Mounting: The Free-Air subwoofers (KMF10, KMF12) do not require an enclosure, however, it is important to isolate the sound coming off the front of the driver from the sound radiating from the back of the driver. This isolation is usually accomplished by using the driver in a factory speaker location, or in a location with a semi-isolated rear chamber.

Infinite Baffle Mounting: The infinite baffle mounting method effectively utilizes the storage space of most boats. Use caution when mounting speakers through any panel of the boat. Please be aware of wiring harnesses, springs, hinges, and folding seat mechanisms that may interfere with the operation of the boat or speaker system. Mark the panel for the hole cut-out diameter of the subwoofer and cut the hole.

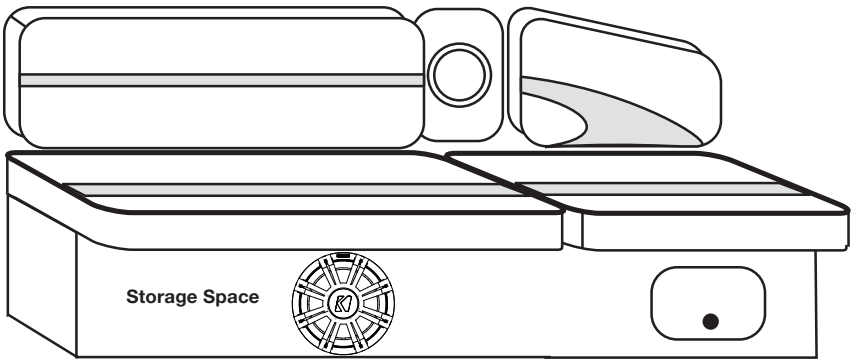
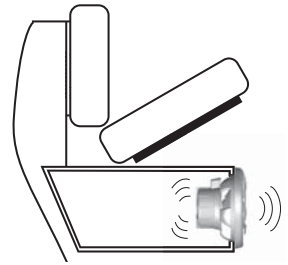

Sealed Enclosures: KM subwoofers perform well in any size sealed enclosure between the minimum and maximum volume recommendations. These systems will exhibit benefits of both designs: Smaller enclosures will produce tight punchy bass, while the larger enclosures will deliver extended low-frequency performance.

These enclosure recommendations have been calculated with the airspace inside the enclosure and include the displacement of the woofer.

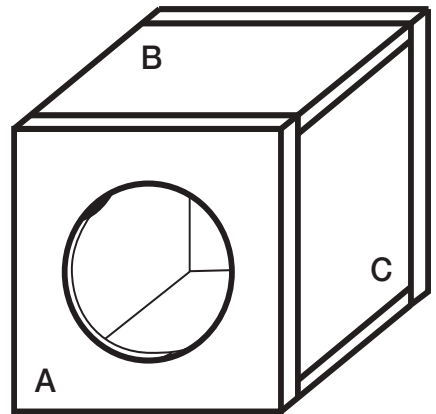

Pro Tip: You are one KXM Amplifier and a few cables away from a complete, high-quality system with rock-solid bottom end as only available from KICKER! Please ask your dealer about KICKER KXM amplifier upgrades.

Model:	Sealed Minimum	Sealed Maximum
KM10	1.0 ft ³ [28.3L] Power Handling = 175W RMS	2.4ft ³ [68.0L] Power Handling = 175W RMS
KM12	1.25 ft ³ [35.4L] Power Handling = 175W RMS	3.5ft ³ [99.1L] Power Handling = 175W RMS

Panel Dimensions for Sealed Minimum Enclosure using 3/4" [1.9cm] thick Marine Grade Plywood:

Model:	Volume ft ³ [L]	Panel A in [cm]	Panel B in [cm]	Panel C in [cm]
KM10	1.0 [28.3]	13.5x13.5 [34.3x34.3]	13.5x12 [34.3x30.5]	12x12 [30.5x30.5]
KM12	1.25 [35.4]	14.5X14.5 [36.8X36.8]	14.5X13 [36.8X33]	13X13 [33X33]

Vented Minimum	KM10	KM12
Box Volume [ft ³ , L]	1.25, 35.4	1.75, 49.6
Port Opening [in x in, cm x cm]	1.5x10.5, 3.8x26.7	2x12.5, 5.1x31.8
Port Length [in, cm]	14.5, 36.8	16, 40.6
Power Handling [Watts RMS]	175	175

Vented Maximum	KM10	KM12
Box Volume [ft ³ , L]	1.75, 49.6	2.25, 63.7
Port Opening [in x in, cm x cm]	1.5x10.5, 3.8x26.7	2x12.5, 5.1x31.8
Port Length [in, cm]	13.25, 33.7	16.375, 41.6
Power Handling [Watts RMS]	175	175

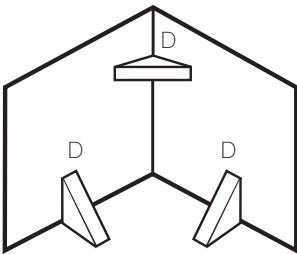

D = 2" x 2" for KM10
D = 3" x 3" for KM12

For the vented enclosures the displacement of the port must be calculated and added to the internal volume of the final design. Use the outer dimensions of the port and multiply "X x Y x Z", convert to cubic feet, for example the KM10 vented minimum design's external port dimensions are, using 3/4" (1.9cm) Marine Grade Plywood:

$[(1.5" + 1.5" \text{ total wall thickness}) \times (10.5" + 1.5" \text{ total MDF wall thickness}) \times 14.5"] \times (1 \text{ ft}^3 / 1728 \text{ in}^3) = .30 \text{ ft}^3$, and add this number to the internal volume of the enclosure, KM10's $1.25 \text{ ft}^3 + .30 \text{ ft}^3 = 1.55 \text{ ft}^3$.

More Box Building Notes: Use 3/4" (1.9cm) or thicker Marine Grade Plywood and seal the joints with silicone. Use the "template" inside your KM subwoofer's shipping carton to mark the mounting hole, then cut directly on the line. These designs need internal bracing. Add triangular bracing between each of the larger unsupported panels.

All of the cubic feet (L) measurements in this manual include the displacement of the woofer.

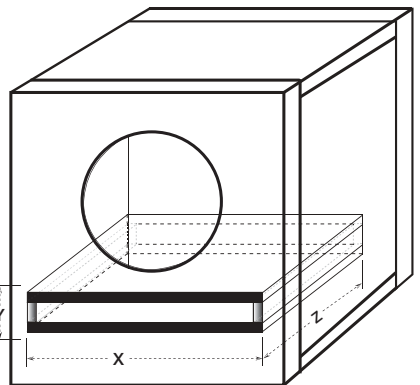

Due to the necessary length of these ports, you may want to fold the port along the bottom and back walls. It will be impractical to use round ports for these designs. The displacement of the port must be calculated and added to the internal volume of the final design.

The dimensions for X, Y, and Z may vary based on the thickness of the material used to make the port. Do not install a port opening against a solid surface, such as an internal brace, back-panel or structural wall, seat or interior panel of your boat. The port opening must remain unobstructed. Use the smallest dimension of the rectangular port as the minimum amount of space between the port opening and any solid surface to insure unrestricted airflow.

LED Grille (sold separately) Wiring: When hard-wiring the RGB lighting, the black lead is +12V and the red, green, and blue leads are ground. There are seven colors available, depending on your wiring configuration. KICKER recommends using the KMLC lighting controller (sold separately) for more colors, patterns, and special effects.

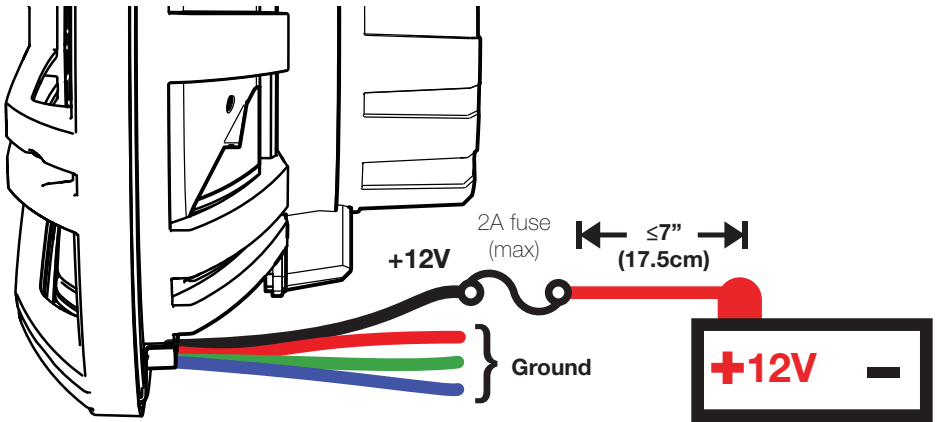

Color Combinations: Splice and combine the ground wires to yield a different color.

Red	Red
Green	Green
Blue	Blue
Red/Green	Lime Green
Red/Blue	Magenta
Blue/Green	Aquamarine
Red/Green/Blue	Blue-White

Note: KICKER Marine speakers meet or exceed industry standards for environmental humidity and corrosion, and for material degradation due to UV exposure. All specifications and performance figures are subject to change.