

Performance Tab Kits



Electro-polished
Blades



Each kit contains:

- Electro-polished stainless steel trim tab blades (2)
- Heavy Duty and Extreme Duty Kits come pre-assembled with stainless steel electro-polished back plates and gland seal (2)
- Standard or Heavy Duty actuators with 6' lead & deutsch plugs (2)
- 20' actuator extension wiring harnesses (2) except for Extreme Duty kits which are sold separately in lengths of 7', 14', 20', 26' and 32'
- Upper mounting bracket with gland seal (2) (standard series only)
- Lower mounting bracket-#119 (standard series only) (2)
- All necessary mounting hardware (standard series only, customer supplied hardware on all others)

Switch sold separately, dual actuator kits must use switch #15071-001(123DRSC)

We make the best boats better!™

Running wide open in rough seas isn't for the faint of heart. Aggressive boating requires durable boat accessories.

Lenco's Performance series of trim tabs are built to handle whatever you or Mother Nature might throw at them. Everything about your boat is designed to go hard and fast. Why should your trim tab system be any different?

- All electro-polished stainless steel construction (no dissimilar metals)
- Actuator speed is precise and controllable so there are no surprises at top speeds
- Heavy and extreme-duty models have massive backplates and adjustable mounting channels with thru-bolted actuators for the ultimate in strength and reliability
- Heavy and extreme-duty models use solid stainless steel billet ends that are electro-polished for unsurpassed durability

3/8" (.95 cm) stainless steel bolts on XD's, 5/16" (.79 cm) stainless steel bolts on HD's

High-impact, ultraviolet resistant nylon 66, 50% glass fiber reinforced thermoplastic housing

Gland seal/strain relief through backplate

Stitch welded heavy duty stainless steel hinge & bracket

Instant response electric actuators are fully submersible, maintenance-free and sealed for life

Adjustable mounting holes

3/8" (.95cm) hinge pins on XD tabs

10-gauge (3.4 mm) laser cut stainless steel trim tab blades and hinges on XD's (12-gauge [2.6mm] on Standard Duty and Heavy Duty)



Deutsch connectors completely waterproof, quick-easy installation

24" x14" Extreme Duty

Performance Tab Kits



Standard Tabs

- #15034-101 (RT 9x9 NS)
- #15035-101 (RT 9x12 NS)
- #15036-101 (RT 12x9 NS)
- #15037-101 (RT 12x12 NS)
- #15038-101 (RT 14x12 NS)
- #15039-101 (RT 16x12 NS)
- #15040-101 (RT 18x14 NS)



Heavy Duty Tabs

- #15041-101 (RT 12x12 HDNS)
- #15043-101 (RT 16x12 HDNS)
- #15044-101 (RT 18x14 HDNS)

All HD Performance tabs are 12-gauge (2.6 mm) electro-polished stainless steel and come pre-assembled

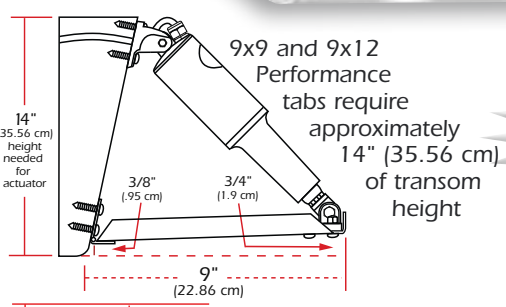

Electro-polished Blades



Electro-polished solid 316 stainless steel billet ends for heavy duty and extreme duty applications

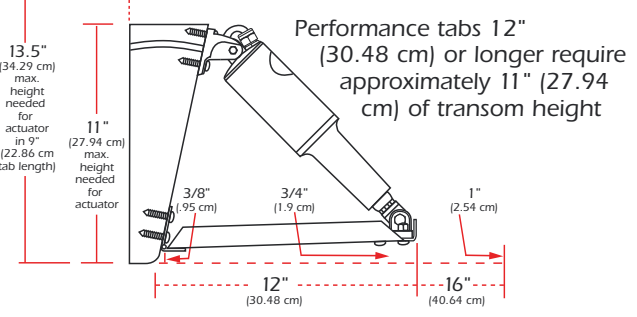

Extreme Duty

- #15045-101 (RT 17x12 XDNS)
- #15046-101 (RT 19x14 XDNS, dual actuator)
- #15047-101 (RT 24x14 XDNS, dual actuator)

All XD Performance tabs are 10-gauge (3.4 mm) electro-polished stainless steel and come pre-assembled

In the part description:

- RT = Performance Tab
- First number represents the tab length
- Second number represents tab width at hinge
- NS = No Switch

Standard Duty

Standard actuator with 5/16" (.79 cm) stainless steel through bolts. 1" (2.54 cm) turned up edges with 2" (5.08 cm) taper on the inside. All 12-gauge (2.6 mm) 304 electro-polished stainless steel blades and hinges.

Heavy Duty

- 12" x 12" HDNS** (30.48 x 30.48 cm)
- 16" x 12" HDNS** (40.64 x 30.48 cm)
- 18" x 14" HDNS** (45.74 x 35.56 cm)

Extreme-duty actuators with 316 stainless steel billet ram. 1" (2.54 cm) turned up edges with 2" (5.08 cm) taper on the inside. Full transom back plate and adjustable C channel mounting brackets with 5/16" (.79 cm) stainless steel mounting studs. All 12-gauge (2.6 mm) 304 electro-polished stainless steel blades with 3-3/4" (9.53 cm) zinc anodes. Gland seal / strain relief through backplate.

Extreme Duty

- 17" x 12" XDNS** (43.18 x 55.88 cm)
- Extreme-duty actuators with 316 stainless steel billet end.
- 19" x 14" XDNS** (48.26 x 35.56 cm)
- 24" x 14" XDNS** (63.5 x 35.56 cm)

Dual extreme-duty actuators with 316 stainless steel billet end. 1" (2.54 cm) turned up edges with 2" (5.08 cm) taper on the inside edge. Full transom back plate and adjustable C channel mounting brackets with 3/8" (.95 cm) stainless steel mounting bolts and 3/8" (.95 cm) diameter hinge pin. All 10-gauge (3.4 mm) 304 electro-polished stainless steel blades with 3-3/4" (9.53 cm) zinc anodes. Gland seal / strain relief through backplate.