



Mach1
SPEED SPIN®

MH100A, MH200A, MH300A

**Driven by innovation –
Fueled with Passion
Feel the Difference!**



10 Bearing System

C40 CARBON

SPEED GEARS

Caractéristiques techniques du moulinet

Modèle	Poids (g)	Freinage max (kg)	Démultiplication	Capacité de ligne (m/kg)	R/TM*
MH100A	221	5,9	6.2:1	110/2,7	76 cm
MH200A	230	5,9	6.2:1	110/3,6	78 cm
MH300A	255	7,7	6.2:1	132/4,5	81 cm

*Rotation par tour de moulinet.

Especificaciones del carrete

Modelo	Peso (g)	Máx. arrastre (kg)	Relación de los engranajes	Capacidad de la línea (m/kg)	RPT*
MH100A	221	5.9	6.2:1	110/2.7	76 cm
MH200A	230	5.9	6.2:1	110/3.6	78 cm
MH300A	255	7.7	6.2:1	132/4.5	81 cm

*Recuperación por giro.

Reel Specifications

Model	Weight (oz.)	Max Drag (lb)	Gear Ratio	Line Capacity (yd./lb.)	RPT*
MH100A	7.8	13	6.2:1	120/6	30"
MH200A	8.1	13	6.2:1	120/8	31"
MH300A	9.0	17	6.2:1	145/10	32"

*Recovery per turn.

FEATURES :

- Rugged, lightweight graphite body
- 10-bearing system includes Zero Reverse one-way clutch bearing
- Lightweight, high strength C40 Carbon skeletal rotor
- Double anodized knurled aluminum spool
- High strength solid brass Speed Gears, cut on precision Hamai CNC gear hobbing machines
- Aluminum handle with Combat style paddle grip
- Speed Lube for exceptional smoothness and uninterrupted performance in all weather conditions from extreme heat to freezing cold
- Adjustable for right or left hand retrieve

Maintenance and Care

While applying lubricant to your Speed Spin® reel, avoid using multi-purpose oil. Use lightweight silicone based oils or greases made for fishing reels. Apply oil to all bearings and the main shaft. Apply grease to the bushings, pinion gears and main gears.

After usage your reel should be inspected for dirt or sand and cleaned if excessive buildup is present. If your reel has come in contact with saltwater it is important to flush all parts with water, dry and re-lubricate your reel. Through diligent cleaning and maintenance your Lew's® reel will provide you with years of reliability and sound performance

ATTENTION BRAIDED LINE USERS!

If your Lew's® Spinning reel has a knurled spool or rubber arbor (designed for tying braided line directly to the spool), you can tie braid directly to your spool using a uni-knot.

If your Lew's® spinning reel does not have a knurled spool or rubber arbor, you will need to first tie on and spool at least 20 revolutions of monofilament line, with either a back-to-back uni-knot or an Albright knot.

Continue to spool your reel as normal, keeping strong tension on the line to ensure the line is firmly wound onto the spool to keep from "digging in" to underlying line layers when pressure is put on the line from fighting fish.

FAILURE TO PROPERLY SPOOL BRAIDED LINE ONTO YOUR REELS SPOOL WILL RESULT IN LINE SLIPPAGE, AND THE IMPRESSION YOUR DRAG IS NOT WORKING PROPERLY.



Machi
SPEED SPIN

MH100A, MH200A, MH300A

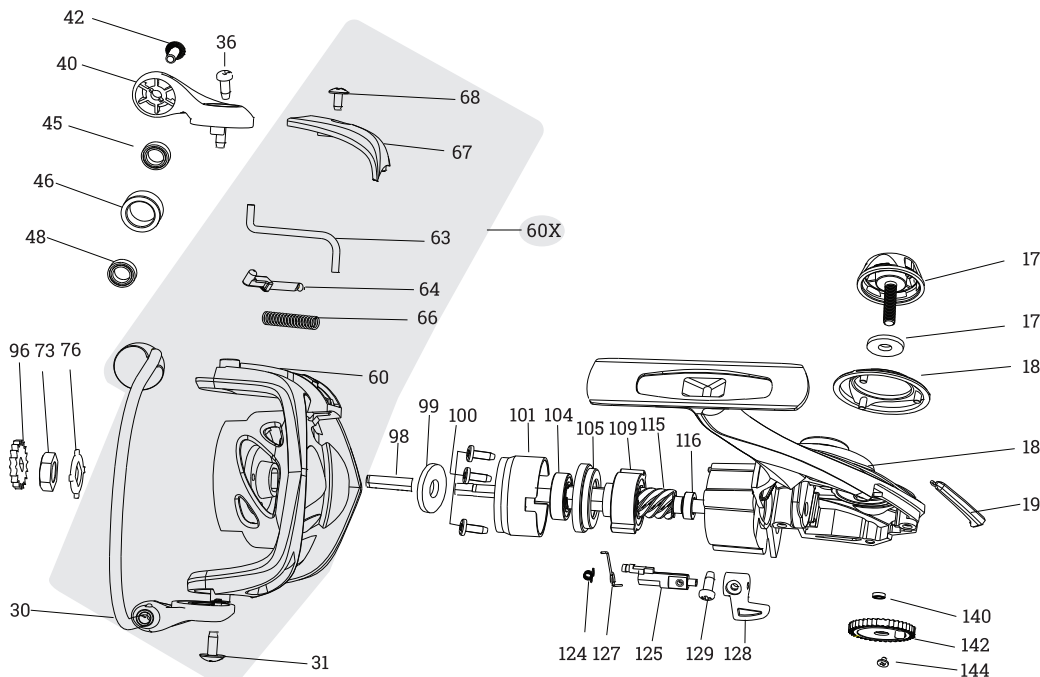
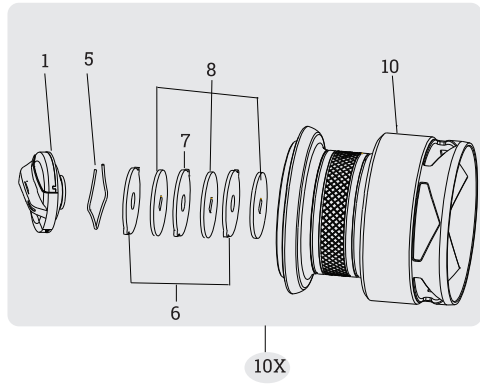

KEY NO.	PART NAME	KEY NO.	PART NAME	KEY NO.	PART NAME	KEY NO.	PART NAME	KEY NO.	PART NAME
1	DRAG KNOB	53	LINE WASHER	90	RING	124	ANTI-REVERSE SPRING	167	BEARING
5	RETAINING RING	54	DRAG WASHER	91	BALL BEARING	125	ANTI-REVERSE	168	ROTOR SHIM
6	KEYED DRAG WASHER (2)	55	LINE WASHER	92	BUSHING	127	ANTI-REVERSE STEM SPRING	169	DRIVE GEAR
7	EARED DRAG WASHER	56	DRAG WASHER	93	BALL BEARING	128	ANTI-REVERSE BUTTON	170	BEARING
8	DRAG WASHER (2)	57	LINE WASHER	95	STACK WASHER	129	SCREW	172	WASHER
10	SPOOL	58	DRAG WASHER	98	MAIN SHAFT	140	BALL BEARING	173	HANDLE CAP
10X	SPOOL ASSEMBLY	60	ROTOR	100	SCREW	142	OSCILLATION GEAR BEARING	181	HANDLE SCREW CAP
25	BALL BEARING	60X	ROTOR ASSEMBLY	101	BODY HEAD COVER	144	OSCILLATION GEAR SCREW	180	BODY
31	SCREW	63	KICK LEVER	104	BALL BEARING	146	SLIDER GUIDE PIN	181	BODY SIDEPLATE SCREW
36	SCREW	64	BAIL ARM SUPPORT PIN	105	BEARING HOLDER	149	SLIDER SHAFT SCREW	184	SIDE COVER TRIM (L)
42	WASHER	66	SPRING	109	ONE-WAY CLUTCH BEARING	150	SLIDER	185	BODY SIDEPLATE
44	BAIL WIRE ASSY	73	ROTOR NUT	115	PINION GEAR	160	HANDLE ASSY WITH	189	SIDE COVER TRIM (R)
45	CLICK GEAR	76	ROTOR NUT WASHER	116	PINION BUSHING	2	BEARING	193	REAR COVER TRIM

