

LEWMAR® LFX

LEWMAR FLUKE ANCHOR

Assembly Instructions & Safe Anchoring Guide iss.1
To be retained in the Owners manual

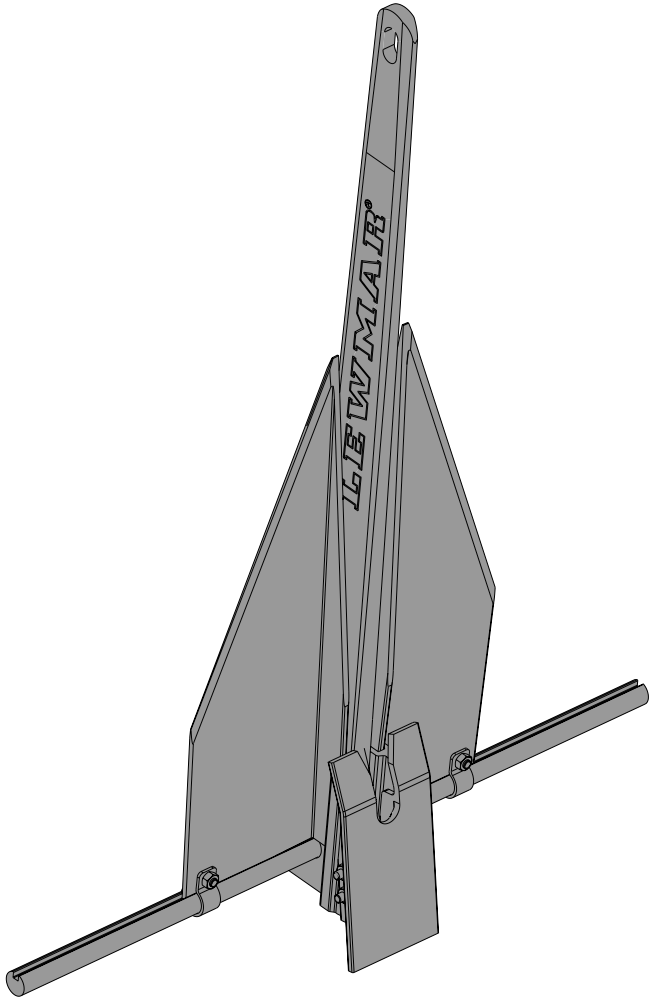

LFX Parts List

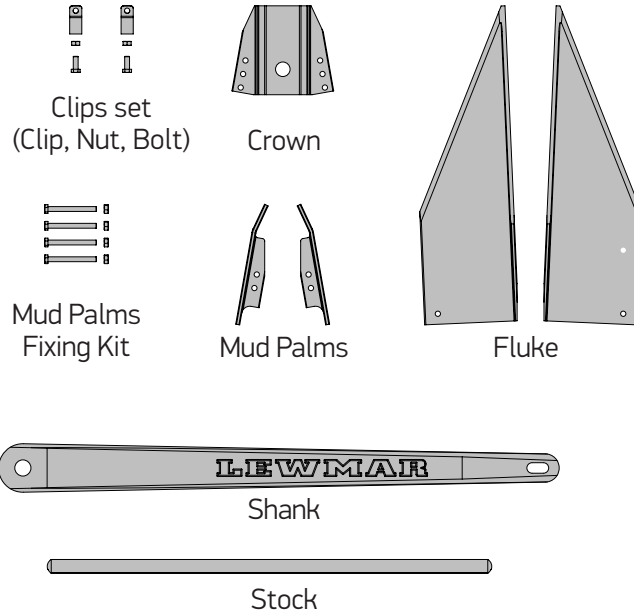

1. Fix the mud palms to the top and bottom of the crown, using 8mm nuts & bolts.

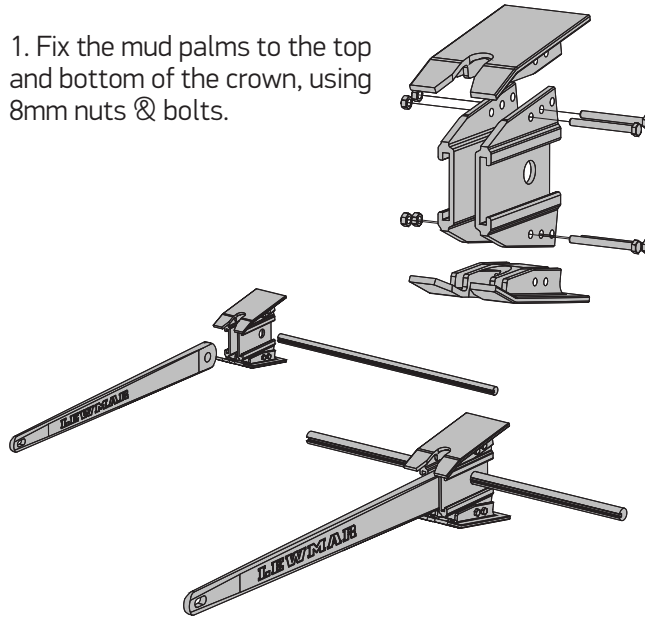

2. Insert the shank into the crown and place stock through the crown and shank.

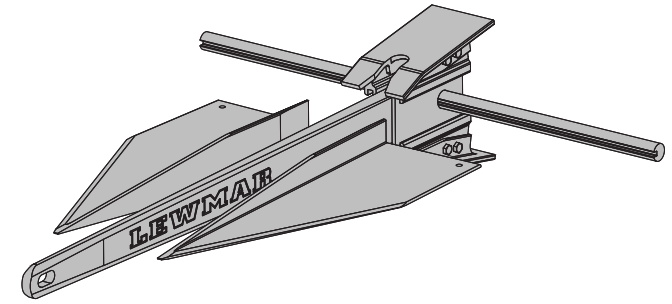

3. Slide flukes into the grooves both sides of the crown.

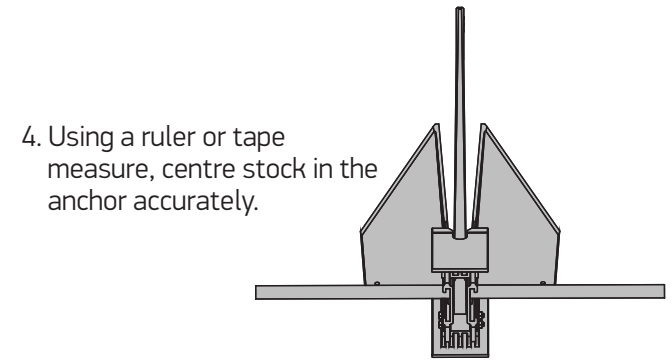

4. Using a ruler or tape measure, centre stock in the anchor accurately.

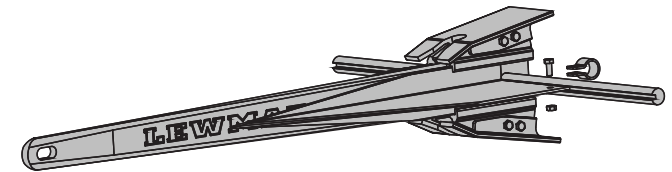

5. Slide clips onto stock and fix through the flukes and tighten nuts and bolts.

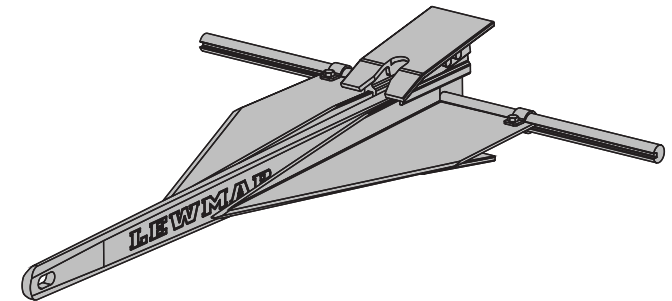

Anchoring with the LFX

Your LFX is a high-performance, reliable anchor with the convenience of low mass and collapsibility for storage. When correct anchoring practice is followed, the anchor will quickly set and provide exceptional holding power. It is important that not only the anchor, but the rode, shackle and strong points are suitable for your usage scenario. This reference guide contains all information you need to get started with confidence.

1. Rode

Your rode should consist of a short length of steel chain and 3-stand nylon line.

The heavy steel chain attached to the anchor helps keep the anchor shank horizontal for optimal setting and holding power. We recommend a minimum length of 6.5ft (2m) of chain. This length is good to approximately 26ft (8m) of water depth. Beyond this, we recommend an additional 6.5ft (2m) per 26ft (8m) depth. For example, 13ft (4m) chain should be used for 52ft (16m) of water depth.

Three-strand Nylon rope is recommended for its good shock-absorbing characteristics. During rough conditions, the rope will reduce the likelihood of the anchor becoming dislodged or damage to the boat. For this reason, a chain-only rode is not advise

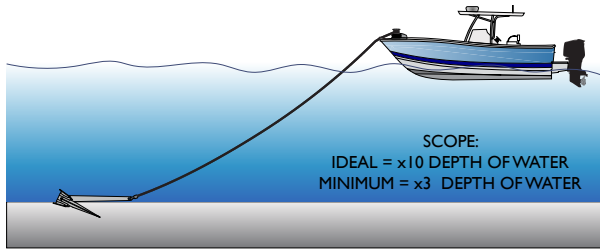

2. Holding Power and Anchor Sizing

Ensure that your LFX is sufficiently sized for your usage scenarios. Use the table below to determine the correct anchor size for a given boat length and wind speed. If in doubt, move up a size.

WIND SPEED	20		25		30		35		40		50		15	
	FT	M	FT	M	FT	M	FT	M	FT	M	FT	M	FT	M
15 kts	90	41	125	57	175	79	225	102	300	1360	400	181		
30 kts	360	163	490	222	700	318	900	408	1200	544	1600	726		
42 kts	720	327	980	445	1400	635	1800	816	2400	1089	3200	1452		
60 kts	1440	653	1960	889	2800	1270	3600	1633	4800	2177	6400	2903		
	lbs	kg	lbs	kg	lbs	kg	lbs	kg	lbs	kg	lbs	kg		

3. Scope

Scope is the ratio of anchor rode length to depth of water. A good scope results in the anchor shank being in position that is more horizontal and parallel to the seabed. The weight of the anchor rode causes it to sag into an arc, which acts as a shock absorber.

The higher the scope, the higher the resulting horizontal pull on the anchor and thus the depth the anchor buries itself. This increases holding power. Where an insufficient scope is used, the anchor shank will be in a position that is closer to vertical. This will reduce holding power and may result in the anchor dislodging.

All scope measurements are based on the waterline. Remember that your depth sounder is likely to be mounted in the keel; be sure to include draft and deck height in scope calculations.

We recommend a minimum scope of 5:1. For example, in 10ft (3m) of depth from the waterline, 50ft (15m) of rode is used. Greater scopes of up to 10:1 will only increase potential holding power. In stormy conditions, try to use a scope close to 10:1. In crowded locations where a high scope is not possible, set at 5:1 then shorten as required to 3:1 minimum.

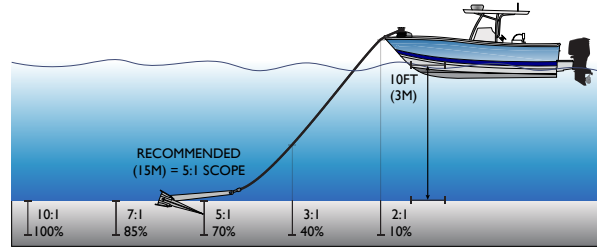

4. Setting

Set your LFX gently by backing down the boat slowly; ideally using tidal currents only. Once the anchor has achieved its initial set, it is advisable to use the engine to provide additional setting pull. Increase the engine speed slowly to drive the anchor further into the seabed.

Attempting to set an anchor at high speed can cause the anchor to drag across the surface rather than snagging and setting.

The chart below shows the approximate thrust produced by your boat's engine. You can use this chart as reference when using setting the anchor with engine assistance. To ensure that the anchor is firmly set, you can use your engine thrust to simulate wind loading on the boat.

	SHAFT HP	25	50	75	100	150	200	300
		TRUE DISPLACEMENT HULLS (SHAFT HP x 20)	lb	500	1000	1500	2000	3000
	kg	225	450	675	900	1350	1800	2700
SEMI DISPLACEMENT HULLS (SHAFT HP x 15)	lb	375	750	1125	1500	2250	3000	4500
	kg	169	338	506	675	1013	1350	2025
FAST, PLANING HULLS (SHAFT HP x 10)	lb	250	500	750	1000	1500	2000	3000
	kg	113	225	338	450	675	900	1350

6. Fluke angle

The LFX design allows the user easy adjustment of the fluke angle to suit different bottom conditions. This is accomplished by adjusting the mud palm position.

The standard fluke angle for the LFX is 30°. This suits general sandy and common medium consistency bottoms. The mud palms should be in the 'aft' position (closer to the shank); this limits the flukes to a 30° angle. When attempting to set the anchor in soft mud or silts, the mud palms should be moved to the forward position (furthest from the shank) to increase the

maximum angle to 45°. Soft substrates can be troublesome, however the 45° LFX flukes reduce the likelihood of the anchor dislodging by shearing out.

If there is difficulty setting the LFX, we recommend reducing the scope to 2:1 initially before letting out more line once the anchor has begun to set. Ensure that the scope is increased to at least 5:1 once the LFX is set.

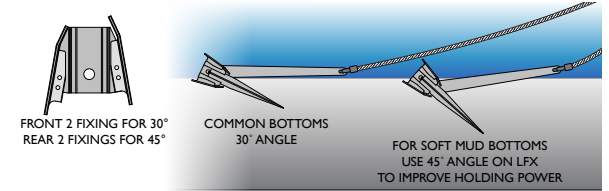

7. Retrieval

Move the boat towards the anchor position whilst pulling in the rode. When the boat is directly above the anchor, it can be broken out with ease. In many cases, smaller anchors can be broken out and retrieved by hand. For stubborn anchors, tie the line off around a cleat or strong point then power the boat backwards slowly with the engine. This will dislodge the anchor from the bottom and allow retrieval.

