

LEWMAR®

68000967 3 BUTTON WIRELESS CONTROL

68000968 5 BUTTON WIRELESS CONTROL

RECOMMENDED WIRING DIAGRAMS FOR LEWMAR PRODUCTS:

- V700, Pro-Series, Pro-Fish, Pro-Sport with Sealed Contactor
- V700, Pro-Series, Pro-Fish, Pro-Sport with Pre-wired Contactor in box
- V1, V2, V3 & V5 with Sealed Contactor
- V1, V2, V3 & V5 with Contactor in Box
- V4 with Sealed Contactor
- V4 with Contactor in Box
- H2 & H3
- 140TT2.0kW Electric Thruster (5 Button Only)
- 140TT2.2kW, All 185TT, 250TT & 300TT Electric Thrusters (5 Button Only)

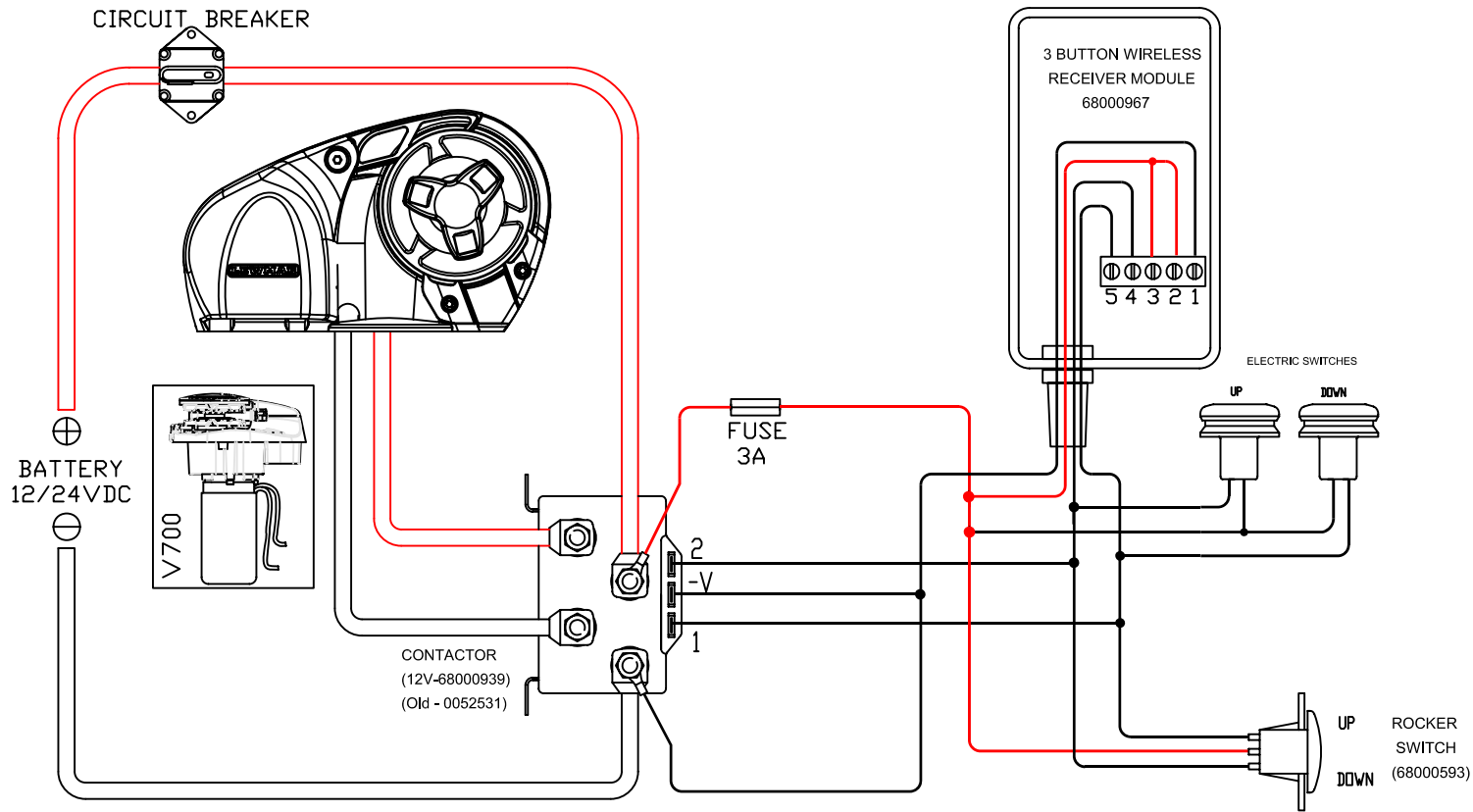

Permanent Magnet Dual Direction Contactor - 68000939 (0052531 - Old)

Wiring Diagram 12VDC

Used on: Pro-Sport, Pro-Series/Fish 700 & 1000, V700, Concept 0, Sprint 600 & 1000, Horizon 600F & 900F

LEWMAR

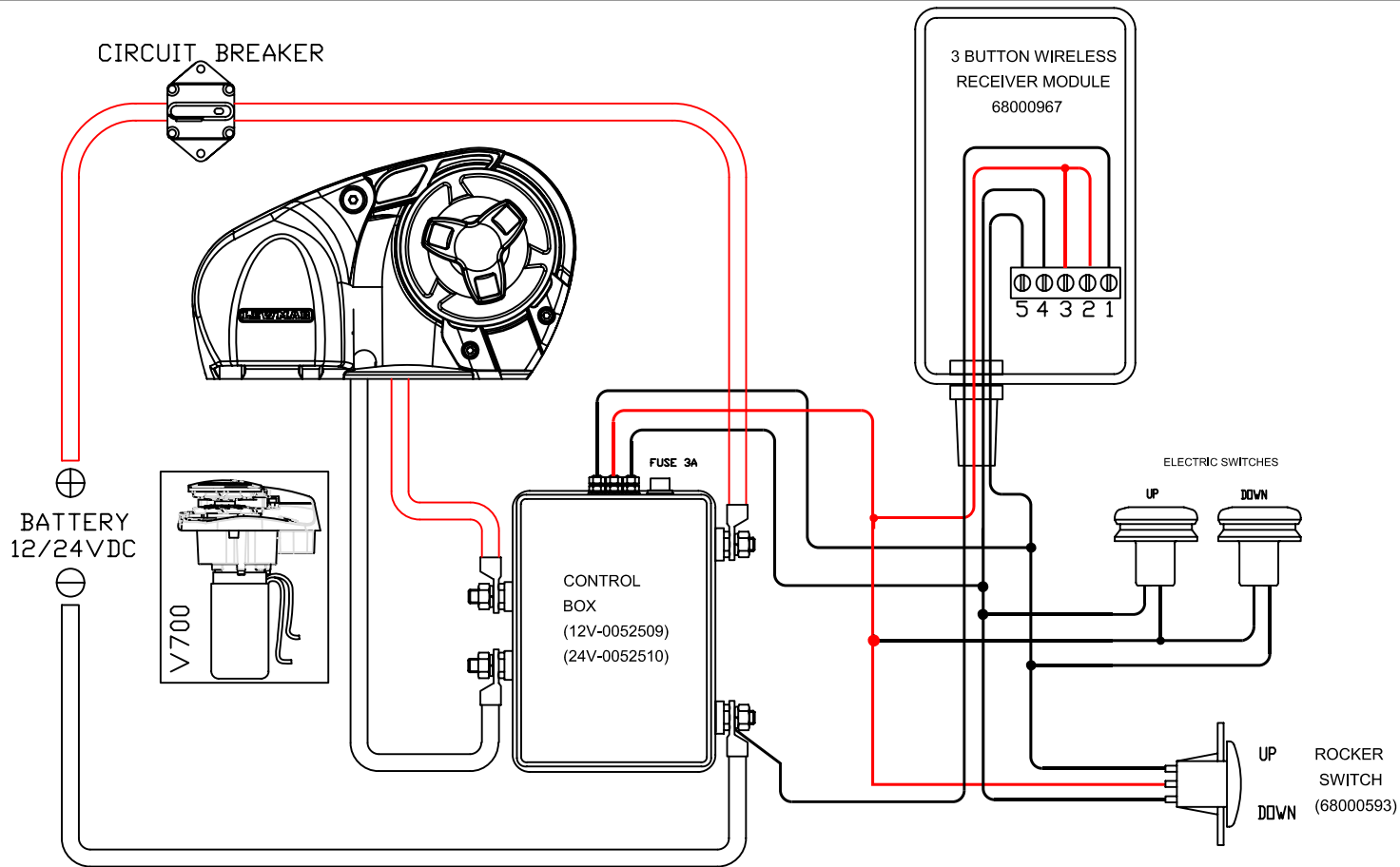

Permanent Magnet Dual Direction Control Box - 0052509/10

Wiring Diagram 12/24VDC

Used on: Pro-Sport, Pro-Series/Fish 700 & 1000, V700, Concept 0, Sprint 600 & 1000, Horizon 600F & 900F

LEWMAR

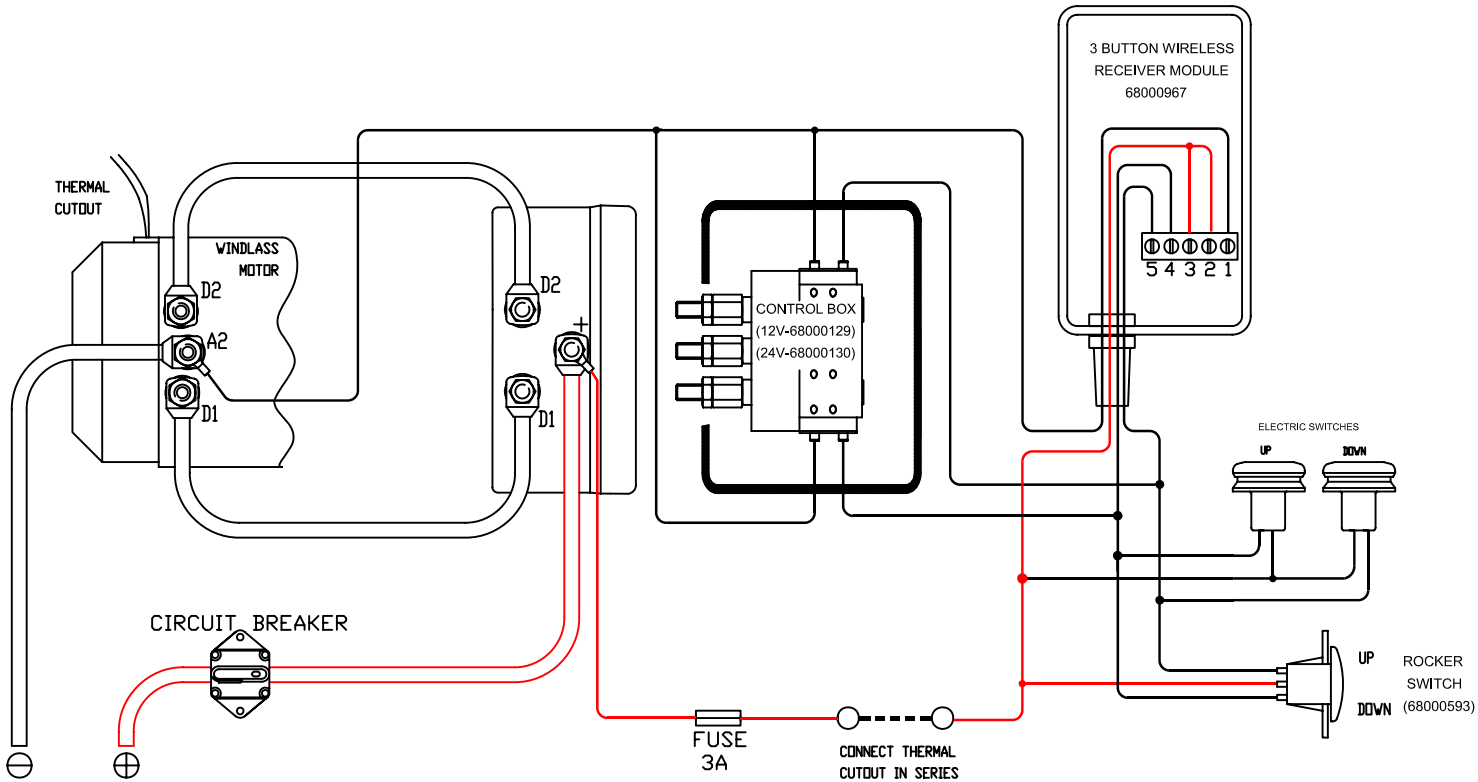

Split Field Dual Direction Control Box - 68000129/130
 Wiring Diagram 12/24VDC only
 Used on: Concept 1, V1, V2, V3, V5

LEWMAR

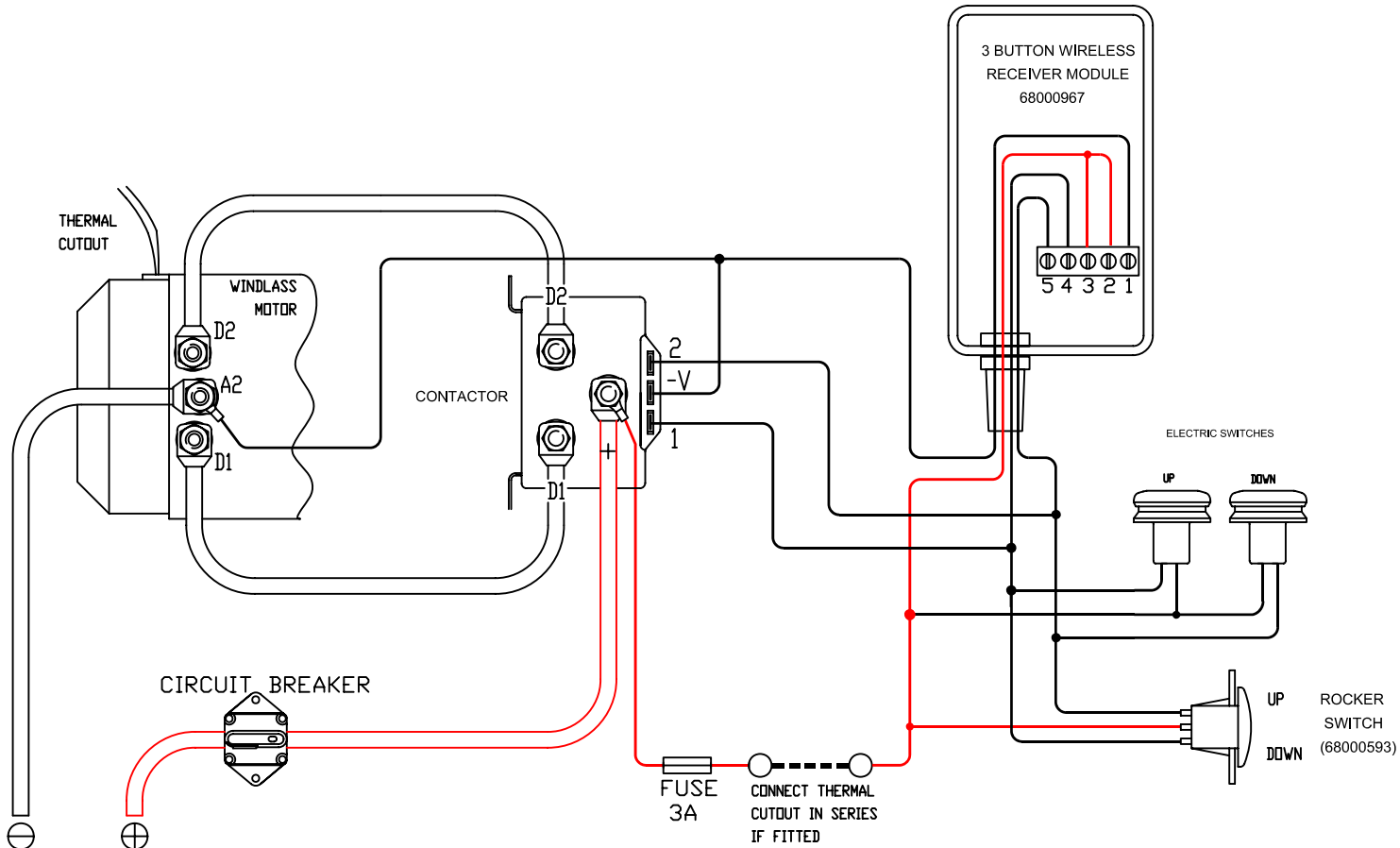

Split Field Dual Direction Contactor
Wiring Diagram 12/24VDC
Used on: Concept 1, V1, V2, V3, V5

LEWMAR

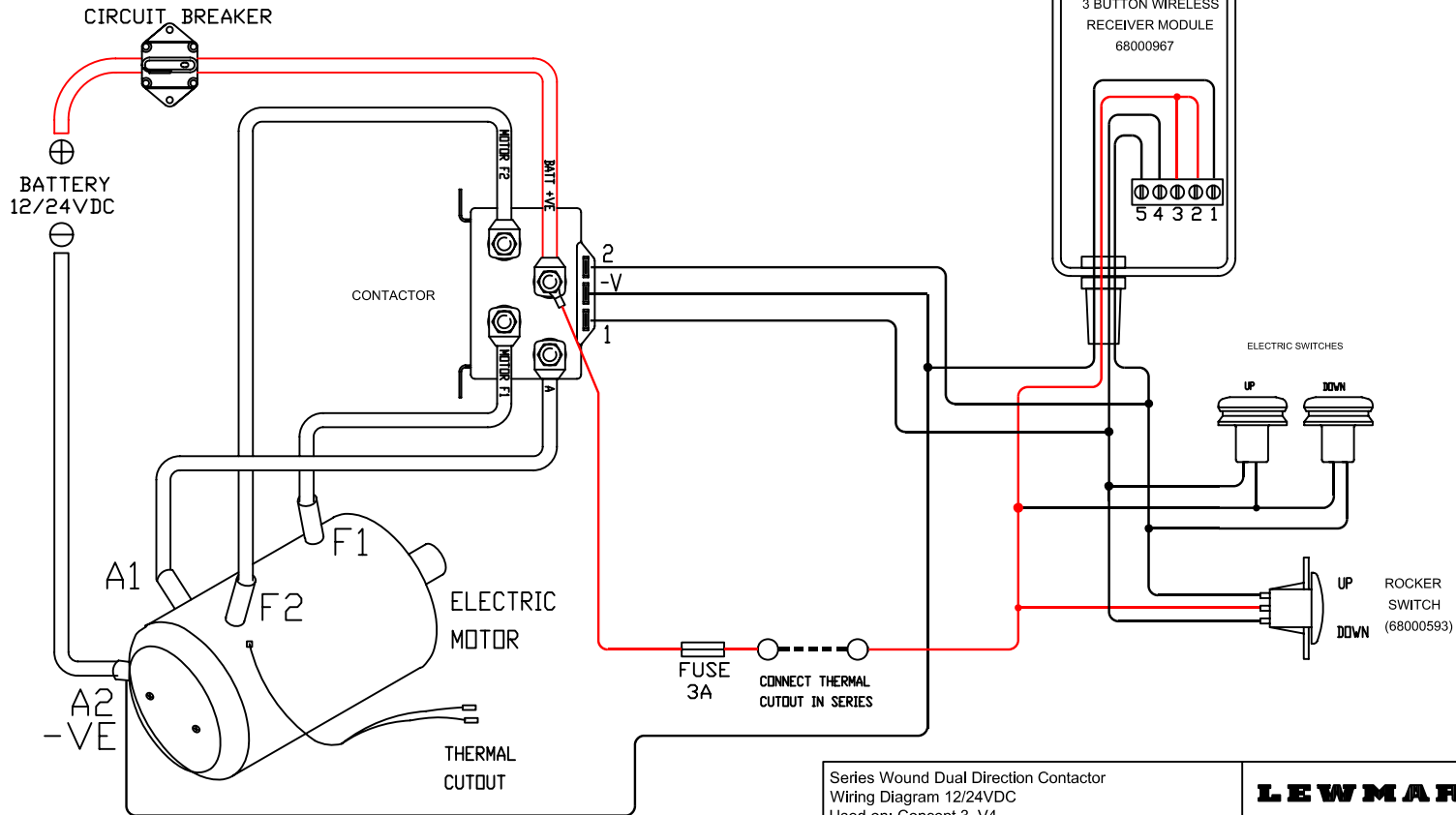

Series Wound Dual Direction Contactor
 Wiring Diagram 12/24VDC
 Used on: Concept 3, V4

LEWMAR

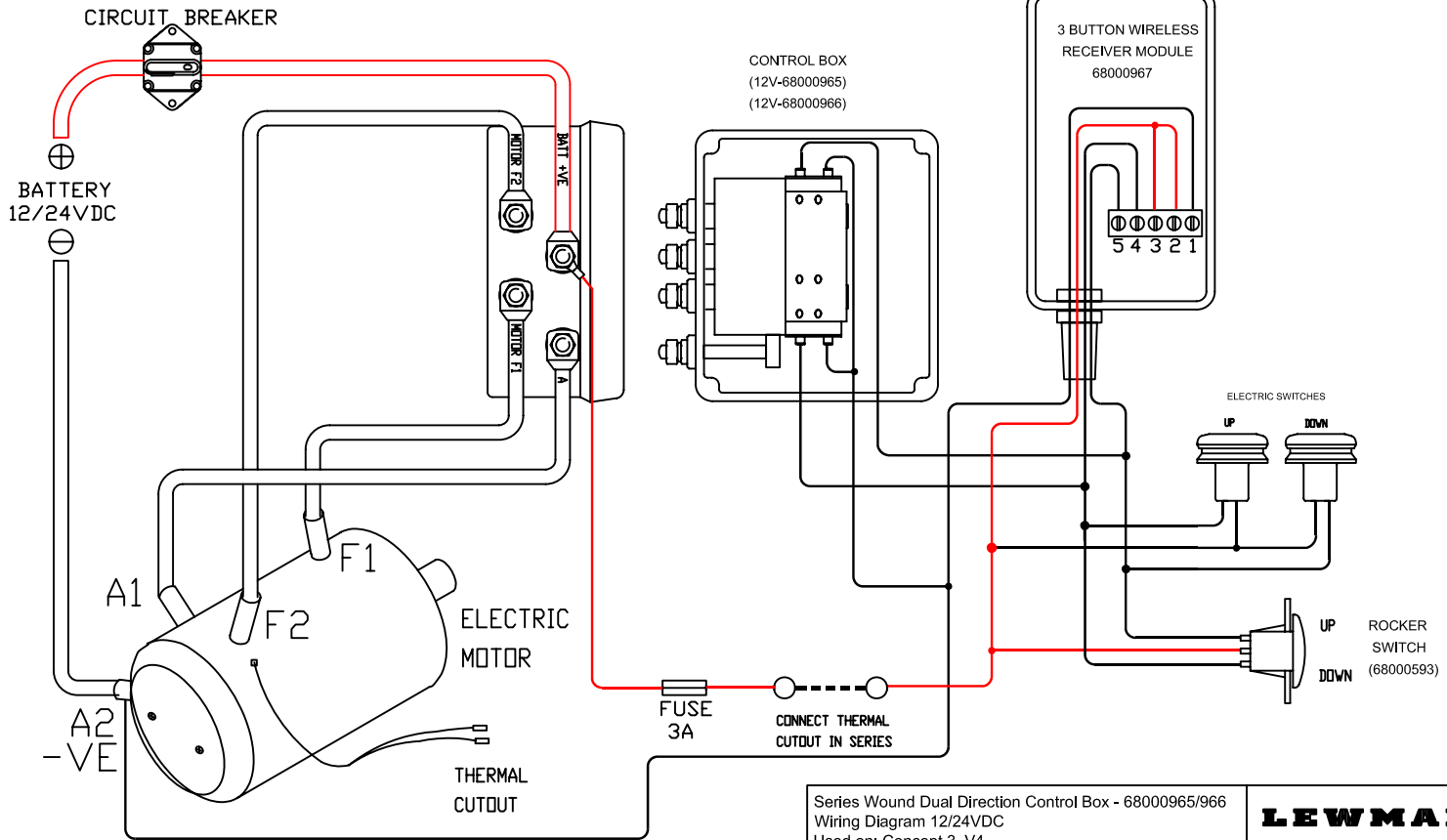

Series Wound Dual Direction Control Box - 68000965/966
 Wiring Diagram 12/24VDC
 Used on: Concept 3, V4



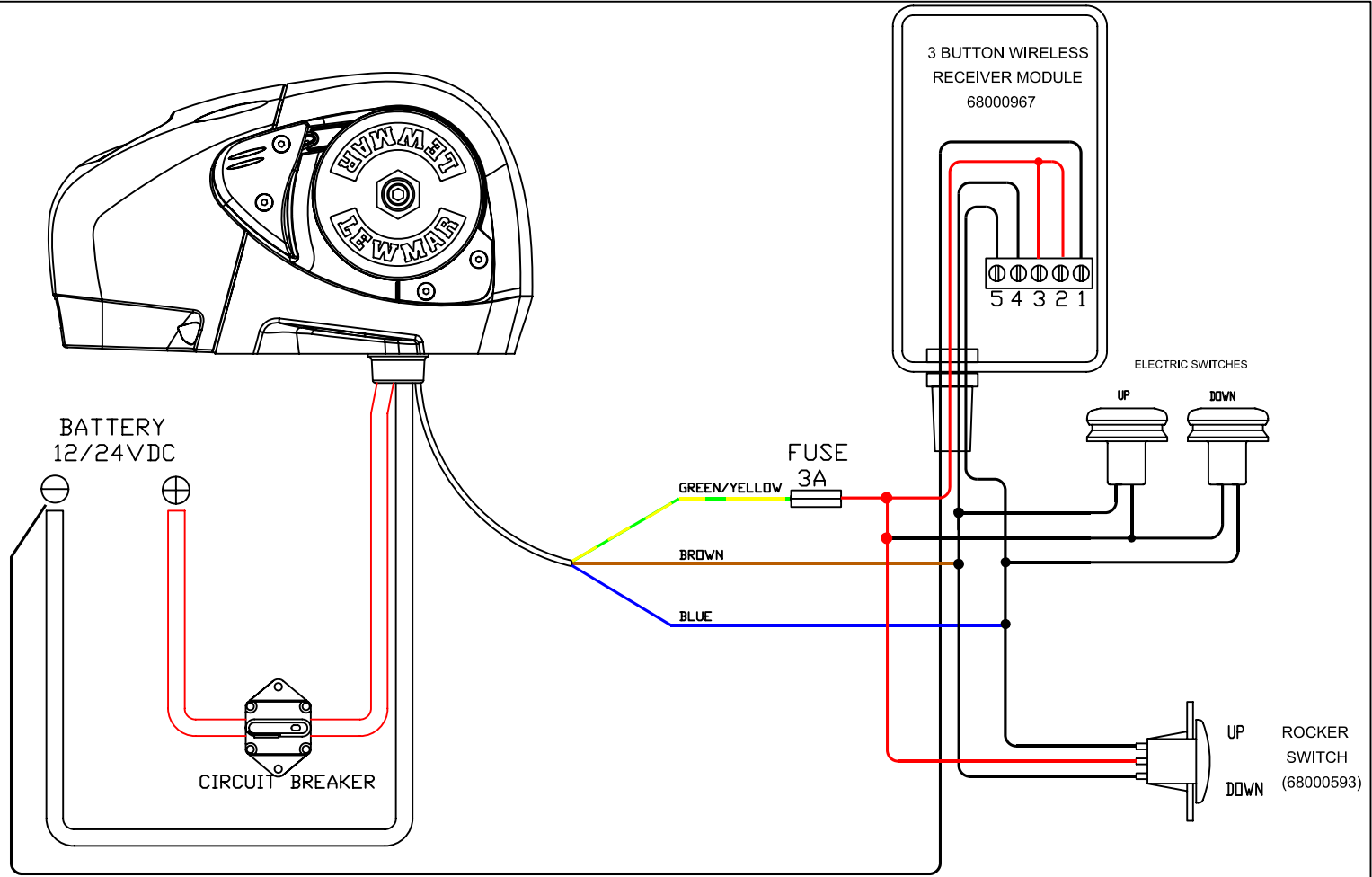

Wiring Diagram 12/24VDC
Used on: H2 & H3

LEWMAR

* For Terminals 1 to 5
Refer to windlass wiring
Diagrams

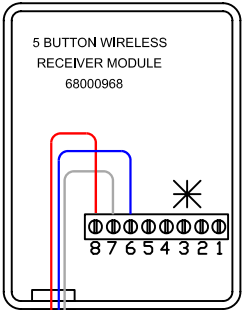
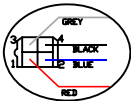
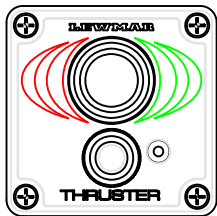

GREY (BLACK-3)

BLACK (GRN/YELL)

BLUE (BLACK-2)

RED (BLACK-1)

To Thruster
Solenoid loom

Thruster Positive Switching system
Wiring Diagram 12VDC
Used on: 140TT2.0KW only.

LEWMAR

* For Terminals 1 to 5
Refer to windlass wiring
Diagrams

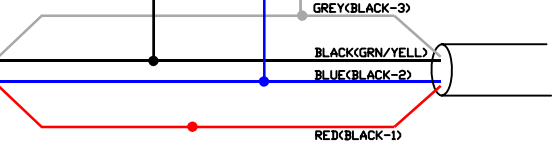
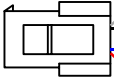
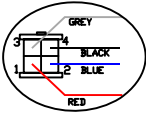
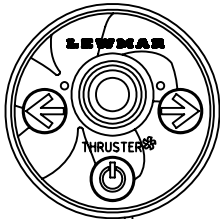
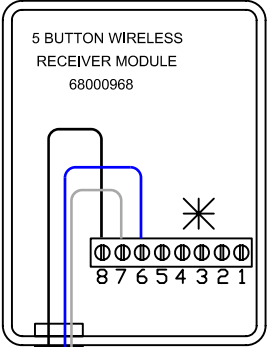

To Thruster Black box
Via Automatic Battery switch if fitted
and/or P/S Battery switch if fitted

Thruster Negative Switching system
Wiring Diagram 12/24VDC
Used on: 140TT, 2.2KW; All 185TT, 250TT, 300TT

