

## DUAL HUB FOLDING WHEEL Installation Instructions

Your **LEWMAR** Folding Wheel can be fitted to either a **LEWMAR / WHITLOCK** standard tapered steering shaft or the 1" parallel shaft utilized by other steering manufacturers such as Edson. The wheel as supplied is assembled with the hub for the standard **TAPERED** steering shaft. (fig 1). To change the hub for 1" **PARALLEL** shaft follow these instructions:

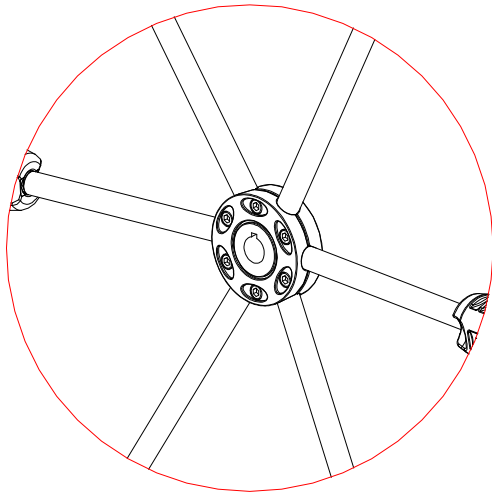

FIG 1 SHOWING WHEEL ASSEMBLED WITH STANDARD TAPERED HUB

1. Remove the six M6 socket headed cap screws from the wheel hub assembly. (fig 2)

**NOTE ! THESE ARE METRIC SCREWS AND A 5mm SOCKET WRENCH MUST BE USED.**

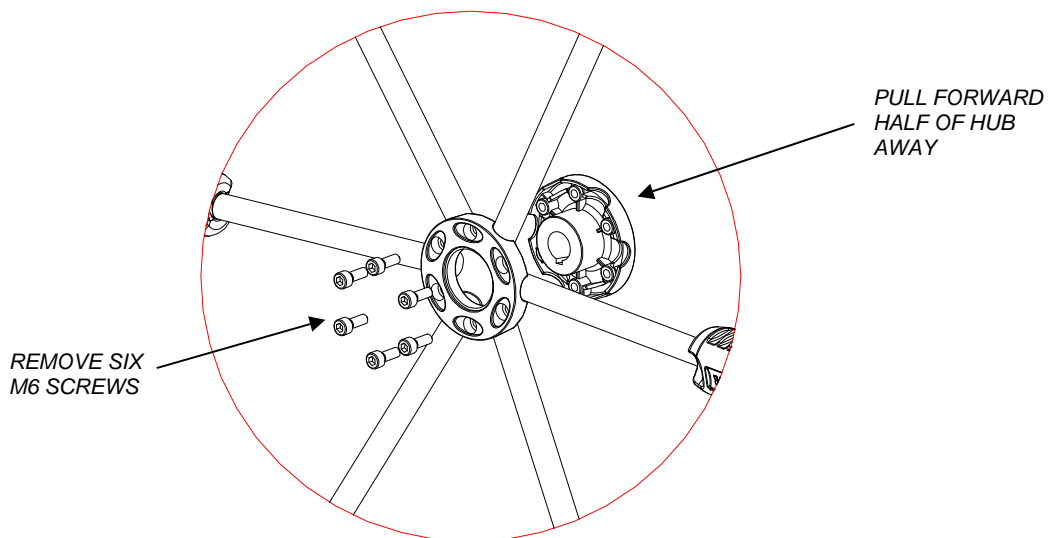

FIG 2: SHOWING SCREWS REMOVED AND FORWARD HALF OF HUB PULLED AWAY

2. With the screws removed, pull away the forward half of the wheel hub. (fig 2)
3. Replace this hub with the **PARALLEL** shaft hub, and fasten using the six M6 socket headed cap screws. (fig 3)

**DANGER !**

**DO NOT STEER YOUR VESSEL WITH THE WHEEL FOLDED**

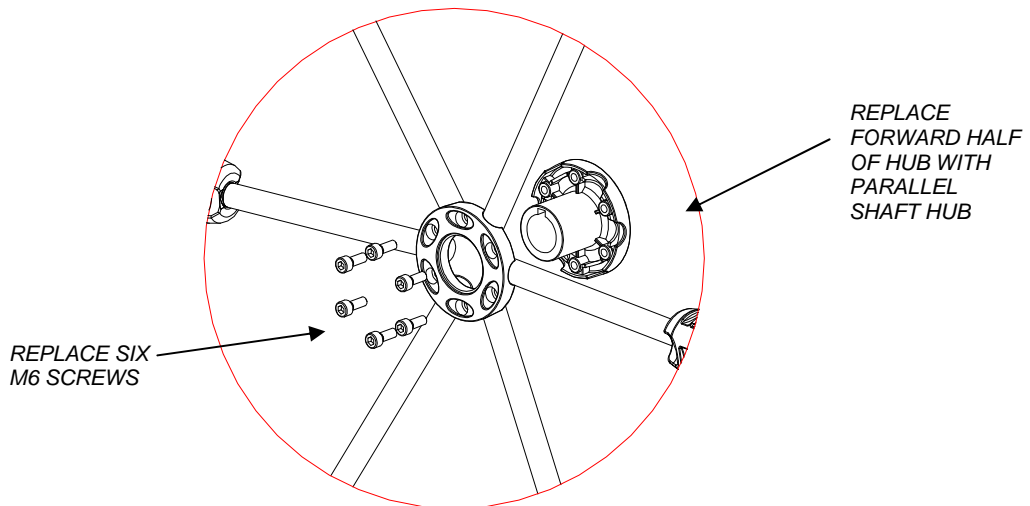

FIG 3 SHOWING PARALLEL SHAFT HUB AND FASTENERS READY TO ASSEMBLE

4. Tighten each screw in turn, ensuring that the two halves of the hub assembly are clamping around the spokes and that an even gap is maintained.
5. Finally tighten each screw in turn, using a TORQUE WRENCH to a torque of **10 ft.lbs (13Nm)**
6. With the wheel assembled fit the wheel to your steering shaft, and while the vessel is moored alongside and NOT underway, steer the wheel from lock to lock to ensure that the wheel hub has been assembled correctly.

**NOTE ! DO NOT USE YOUR WHEEL IF THERE IS ANY MOVEMENT WITHIN THE HUB ASSEMBLY. REMOVE SCREWS AND RE-ASSEMBLE TO THE INSTRUCTIONS ABOVE.**

7. Before using your wheel, check the tightness of the six M6 cap headed screws with a TORQUE WRENCH

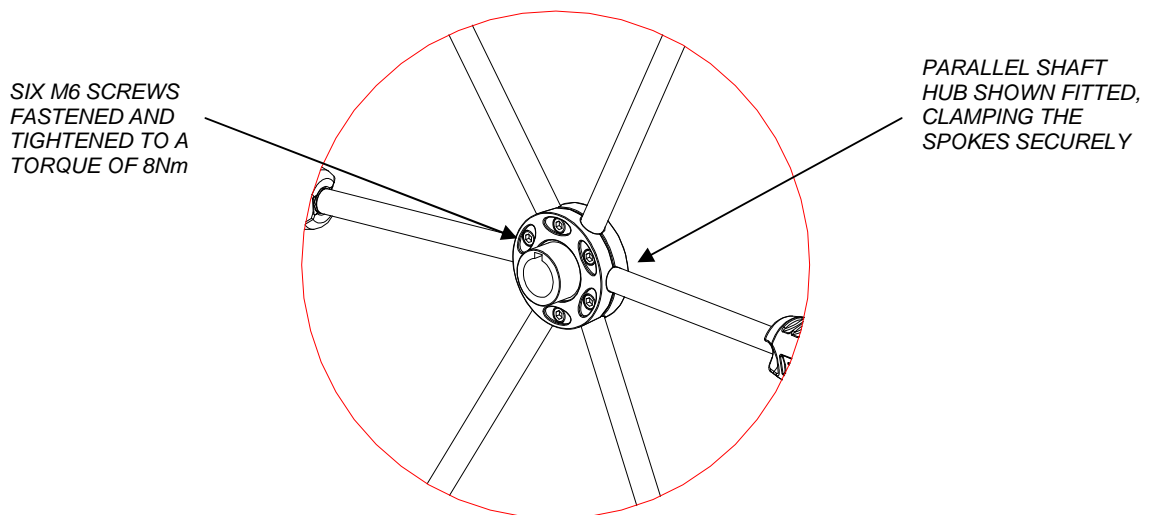

FIG 4. WHEEL ASSEMBLED WITH PARALLEL SHAFT HUB

**DANGER !**  
**DO NOT STEER YOUR VESSEL WITH THE WHEEL FOLDED**