



- Position LED Indicators
- Electronic Throttle & Shift Controls
- Digital CAN Bus Gauges
- Trim Tabs
- Exhaust Systems
- Fuel Senders
- Mechanical Controls
- LED Navigation Lights
- Precision Gauges
- Data Gateways
- Sea Strainers
- Accessories
- Wire Harnessing



Volume 2

INDUSTRIAL • MARINE • AUTO • COMMERCIAL



Livorsi Marine, Inc. has been supplying gauges, controls and accessories to the high performance, work boat, commercial and the government sector for 25 years. Livorsi has become standard equipment in major performance boat builders including Baja, Cigarette, Donzi, Formula, Nor-Tech, Skater and Fountain among many others. Our products are synonymous with quality and meet the highest of standards.



When it comes to high-quality, superior performance and stunning display under the hatch, no one can touch CMI. For more than two decades Custom Marine stainless steel headers and exhaust systems have been installed on more National and World Championship power boats than all other brands combined. CMI is now ready to serve the industrial market with industry-leading technologies, top marine engineers and skilled stainless steel fabricators.



## Table of Contents

Billet Battery Boxes	51
Courtesy Lights (LED)	32
Fire Extinguisher and Mounts	52
Foot Pedal (electronic)	31
Gateways	
Livorsi Data Gateway	29
Mercury® MercMonitor	27
Mercury® Gateway	28
Gauges	
Industrial Series Gauges	11
Raw Water Flow Gauge	44
Vantage View® CAN Bus Gauges	18
Hatch Actuators	53
Indicators	
Adjustable Position LED Indicators	36
Mechanical Indicators	47
Navigation Lights	32
Night Vision Camera (Low Lux)	54
NMEA 2000® Harnessing	42
Sea Strainers	57
Senders - Fuel/ Water Level	45
Stainless Steel Exhaust	55
Steering Wheels	50
Steering Wheel Hub Adapter	51
Switches	53
Throttles and Controls	
Electronic	8
Livorsi DTS Controls (Digital Throttle & Shift)	4
Livorsi ETS Controls (Electronic Throttle & Shift)	8
Mechanical	
Billet	6
Binnacle	9
Standard	6
Transom Tips	56
Trim Panels	49
Trim Tabs (hydraulic)	34
Wire Harness Solutions	43

## Livorsi DTS Controls- Single Function

Livorsi DTS Controls (Digital Throttle & Shift) provide consistent precise control of your boat using SmartCraft® DTS technology. A license from Mercury Marine allows Livorsi to combine DTS technology with the options and quality of Livorsi controls.

These controls provide smooth and safe shifting. Direct drive of throttle position sensors eliminates the need for engine control cables, thus resulting in a quick response. Designed with a compact body for tight spaces and constructed of stainless steel and billet aluminum for years of dependable service.

Designed to work on all Mercury DTS equipped engines (Verado 150 - 350 SCI, Mercruiser 5.0L - 8.2L, Optimax 225, Mercury Racing 565, 1100, 1350, and Cummins engines that are DTS capable.

- Single, twin, triple and quad engine applications
- Ability to adjust tension for each handle
- Integrated single or twin drive trim switches or momentary up and down switches

Shadow Mode available for automatic throttle synchronization for triple or quad engine applications; where two throttle levers operate three engines or four engines. Requires appropriate Mercury Shadow Mode rigging kit.



### Electrical Requirements

DTS equipped boats require that the electrical systems meet the following guidelines: Use only marine starting batteries with a 1000 mca /800 cca/ 180 amp hour rating or higher. Deep cycle batteries do not deliver the power required for the DTS system.

### Notice to Personnel Installing this Kit

The installation of this product requires an installer who is specifically trained to work on Mercury Marine's digital throttle and shift (DTS) systems. The installer must be trained in the proper installation, electronic calibration, and operation of the DTS system. Failure to correctly install this product may make this product and /or the DTS system inoperable or unsafe for use and will void the warranty. Please call Livorsi Marine to find a certified dealer/technician near you.

# Livorsi DTS Controls

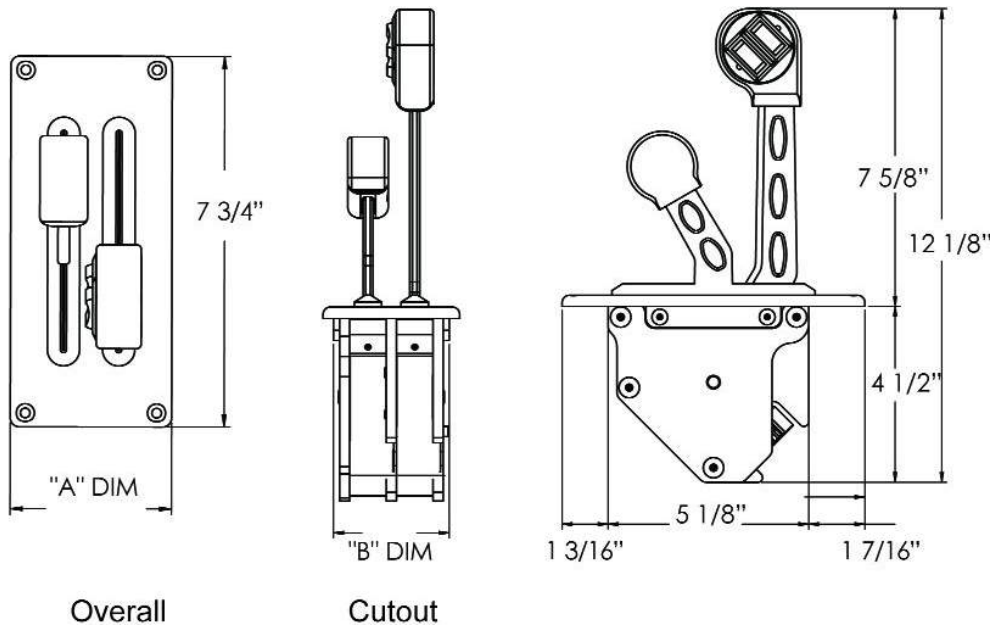

Dimensions				
# of Handles	Overall		Cutout	
	A DIM		B DIM	
2 handle	3 3/8 in.	7 3/4 in.	2 7/8 in.	5 1/8 in.
3 handle	4 1/2 in.	7 3/4 in.	4 1/64 in.	5 1/8 in.
4 handle	5 11/16 in.	7 3/4 in.	5 3/16 in.	5 1/8 in.
6 handle	8 in.	7 3/4 in.	7 1/2 in.	5 1/8 in.
8 handle	10 5/16 in.	7 3/4 in.	9 13/16 in.	5 1/8 in.

Chrome Base			
# of Handles	No Switch	Single Switch	Dual Switch
2 handle	DTSBB11 + color	DTSBB11S + color	DTSBB11D + color
4 handle	DTSBB22 + color	DTSBB22S + color	DTSBB22D + color
6 handle	DTSBB33 + color	DTSBB33S + color	DTSBB33D + color
8 handle	DTSBB44 + color	DTSBB44S + color	DTSBB44D + color
Powder Coat Base			
# of Handles	No Switch	Single Switch	Dual Switch
2 handle	DTSBB11PC + color	DTSBB11SPC + color	DTSBB11DPC + color
4 handle	DTSBB22PC + color	DTSBB22SPC + color	DTSBB22DPC + color
6 handle	DTSBB33PC + color	DTSBB33SPC + color	DTSBB33DPC + color
8 handle	DTSBB44PC + color	DTSBB44SPC + color	DTSBB44DPC + color
Mercury DTS Rigging Kits			
Single Engine	Twin Engine	Triple Engine	Quad Engine
84-892955K04	84-893378K04	892955K32	Order (4) Single Engine
Mercury Shadow Mode Rigging Kits			
Triple Engine	Quad Engine		
8M8025983	8M8025984		

## Mechanical Controls - Single Function

- For single, twin, triple and quad engines
- Compatible with bucket, jet drives, shifts or throttles
- Enclosed wiring in the handles
- Lever resistance is adjustable while installed in the dash
- Configurations available to operate jet boats, drives and throttle controls

In addition to the part number, please specify when ordering:

1. Handle configuration  
shift- shift- throttle- throttle or split configuration
2. Left or right hand thumb placement for trim switches
3. Cant forward or cant backward

---

### Standard Controls

- Constructed of bronze and stainless steel
- Entire unit is powder coated one solid color
- Installation requires the use 33C or 43C series cables,  
2 cables per engine: one for shift, one for throttle

Colors:  PL  BK



---

### Billet Controls

- Constructed of billet aluminum
- Available with bent or straight handles
- Handles and base have a chrome finish
- Base can be powder coated for an extra charge
- Knobs available in color of your choice
- Installation requires the use 33C or 43C series cables,  
2 cables per engine: one for shift, one for throttle

Colors:  PL  BK



Dimensions		
# of handles	Overall	Cutout
	A DIM	B DIM
2 handle	3 1/4 in. x 7 3/4 in.	2 5/8 in. x 6 1/2 in.
3 handle	4 3/8 in. x 7 3/4 in.	3 3/4 in. x 6 1/2 in.
4 handle	5 5/8 in. x 7 3/4 in.	4 3/4 in. x 6 1/2 in.
6 handle	7 3/4 in. x 7 3/4 in.	7 in. x 6 1/2 in.
8 handle	9 7/8 in. x 7 3/4 in.	9 3/16 in. x 6 1/2 in.

# Mechanical Controls

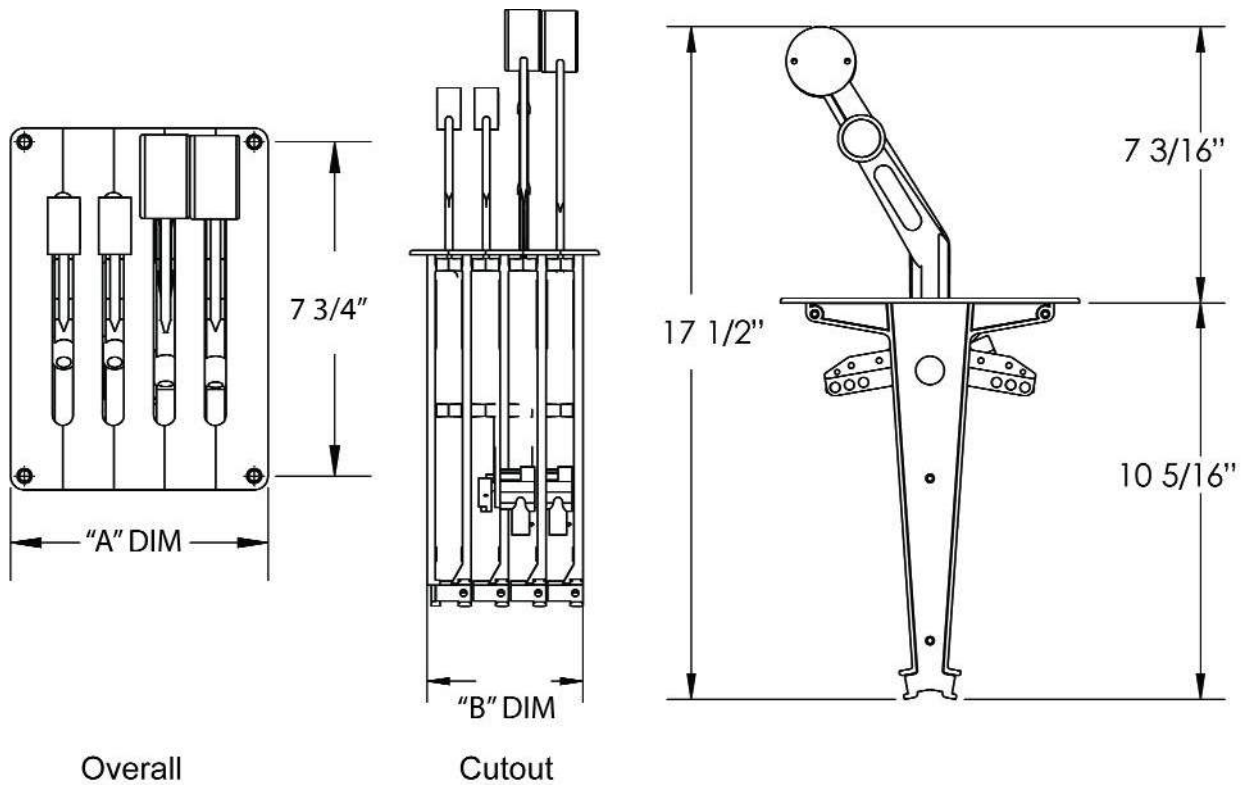

Overall

Cutout

Standard Controls			
# of Handles	No Switch	Single Switch	Dual Switch
1 handle	TH1 + color	TH1S + color	TH1D + color
2 handle	TH11 + color	TH11S + color	TH11D + color
3 handle	TH111 + color	TH111S + color	TH111D + color
4 handle	TH22 + color	TH22S + color	TH22D + color
6 handle	TH33 + color	TH33S+ color	TH33D + color
8 handle	TH44 + color	TH44S+ color	TH44D + color

Billet Controls- Bent Handle			
# of Handles	No Switch	Single Switch	Dual Switch
1 handle	THBRB1 + color	THBRB1S + color	THBRB1D + color
2 handle	THBRB11 + color	THBRB11S + color	THBRB11D + color
3 handle	THBRB111 + color	THBRB111S + color	THBRB111D + color
4 handle	THBRB22 + color	THBRB22S + color	THBRB22D + color
6 handle	THBRB33 + color	THBRB33S+ color	THBRB33D + color
8 handle	THBRB44 + color	THBRB44S+ color	THBRB44D + color

Billet Controls- Straight Handle			
# of Handles	No Switch	Single Switch	Dual Switch
1 handle	THBRS1 + color	THBRS1S + color	THBRS1D + color
2 handle	THBRS11 + color	THBRS11S + color	THBRS11D + color
3 handle	THBRS111 + color	THBRS111S + color	THBRS111D + color
4 handle	THBRS22 + color	THBRS22S + color	THBRS22D + color
6 handle	THBRS33 + color	THBRS33S+ color	THBRS33D + color
8 handle	THBRS44 + color	THBRS44S+ color	THBRS44D + color

# Livorsi ETS Controls - Single Function

Livorsi ETS Controls (Electronic Throttle & Shift) provide smoother shifting and throttling than traditional controls with the use of dual redundancy potentiometers.

The potentiometers used for these electronic controls contain two independent outputs for redundancy. Fully sealed to meet or exceed IP66/IP67 standards, the potentiometer is impervious to moisture and contamination. It also features excellent temperature stability and is constructed of anti-corrosive material.

- Single, twin or triple engine applications
- Utilizes dual redundancy position sensors
- Shifters can remain mechanical with 33C or 43C cables or can be electronic with micro switches forward and aft
- Bucket controls, shifters or throttles can be stacked together or separate

The following components can be added to your mechanical controls to “electrify” them to communicate with various engines:

Steyr • Cummins • Iveco • Fiat • Yanmar • Banks • Bosch controllers

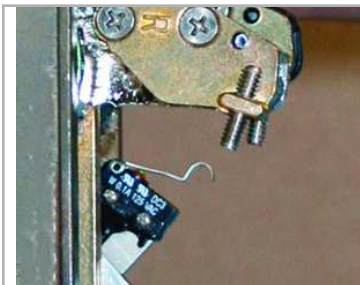

ESSA switch forward and aft for shift levers



ETPAS dual redundancy pot for throttle lever

**Part Numbers: ETPAS or ETPAT (pots)**

- Added to throttles or shifts
- 0-5 volt dual redundancy pots

Please specify when ordering:  
- For shift or for throttle

**Part Number: ESSA**

- Waterproof switches, forward and aft that can activate a solenoid to shift a transmission
- One switch is required for each handle
- Connectors with flying leads are supplied

Description	Part Number
single engine assembly 0-5V	ETPAS
twin engine assembly 0-5V	ETPAT
triple engine assembly 0-5V	(1) ETPAS, (1) ETPAT
shift assembly switch - 1 required for each handle	ESSA
connector with 18" flying lead 0-5 V pot	ETS5VH
Cummins Harness 20 ft	CMDH20
Cummins Harness 25 ft	CMDH25
Cummins Harness 30 ft	CMDH30
Steyr Harness 20 ft	HSTH20
Idle Validation Switch needed for Steyr application	ETSIVS

See page 7 for control part numbers and dimensions.



Single Engine Binnacle - Electronic Throttle-Mechanical Shift



Product Features:

- Mechanical shift accepts 33c series cables for push or pull applications
- Electric throttle: IP68 sealed dual redundancy, programmable voltage pots
- Built in push button to disengage throttle for warm up
- Constructed of billet aluminum and stainless steel with a robust powder coat finish
- 180° of throw
- Single or dual trim switches
- Adjustable detent and friction
- Small cutout foot print
- Plug-in Deutsch connector for electronic throttle

Colors:  **PL**  **BK**

# of Handles	No Switch	Single Switch	Dual Switch
1 handle	TBD	TBD	TBD

Binnacle Mount - Mechanical Throttle & Shift

Product Features:

- Supports outboard and sterndrive configurations using 33c cables
- Add up to 4 momentary switches depending on your application requirements
- Throttle only button
- Adjustable friction settings for throttle and shift

Colors:  **PL**  **BK**

# of Handles	No Switch	Single Switch	Dual Switch
1 handle	BMCM1 + color	BMCM1S + color	BMCM1D + color
2 handle	BMCM2 + color	BMCM2S + color	BMCM2D + color
# of Handles	3 Switches		4 Switches
1 handle		BMCM1T + color	BMCM1Q + color
2 handle		BMCM2T + color	BMCM2Q + color



# Control Hardware

## 33C Series Cables

- Sold in two foot increments
- Sizes range from 10 feet to 38 feet
- Use with Livorsi controls or mechanical indicators
- Stainless steel core
- Chrome plated brass
- 3 1/4" throw
- Threaded ends, size 10x32

Description	Part #
33C Series Cable	CA + length



## Neutral Safety Switch

Allows you to start engine only when in neutral. One needed for each shift lever. Included at no charge with your control order.

Description	Part #
safety switch	NSS

## Trim Switches

for Standard, Billet or ETS controls

Description	Part #
single no wires	TSSO
single w/ wires	TSSW
single w/ wires & plate	TSSWP + color
single w/ wire, plate & back plate	TSSWPB + color
dual w/ wires & plate	TSDWP + color
dual w/ wires, plate & back plate	TSDWPB + color
Note: will not work on Mercury® controls.	

## Cable Connection Kits

Description	Part #
Mercury OB 1 shift/1 throttle	CCKOBM
Mercury I/O 1 shift/1 throttle	CCKIO
OMC OB 1 shift/1 throttle	CCKOBO
Cable Connection Kit for 33C (included at n/c with control order)	CCK30
Cable Connection Kit for 43C	CCK40
cable connector 90 degree	QDBJ
throttle bracket clip	TBC



## Diode Kits

- 3 amp, 1000V

Description	Part #
diode kit- diodes only 4 piece kit for twin engine	DK
diode plug in harness- twin	DKH2
diode plug in harness- triple	DKH3

## Throttle Adapter Plates

- Adapts a Mercury® control cutout to accept Livorsi controls
- Made of aluminum
- Available in a white powder coat finish
- 2 handle measures: 3 1/2" W x 9 1/2" L
- 4 handle measures: 5 3/4" x 9 1/4" L

Description	Part #
2 handle	TAP2W
4 handle	TAP4W

# Industrial Series Gauges

Livorsi Industrial Series gauges are built for resilient performance and durability. Designed for marine, automotive and off road applications.

These analog gauges feature exceptional contrast with bold white graphics and pointer on a black dial.



The old style terminal connections of the gauge have been replaced with waterproof plug in Deutsch connectors. The Deutsch harness (DCH) plugs in to the back of the gauge and the 18 inch wire leads are labeled for your convenience.

These gauges are available for a 12 or 24 volt system, please specify when placing your order.

- Plug in connectors are waterproof and resist salt corrosion
- Encased in non-ferrous hardware
- Red LED lighting is standard, increases visibility in low light conditions
- Fade resistant powder coated pointers
- SAE rims in black powder coat or polished stainless steel



Function	cutout size	overall size
Tachometer	3 3/8"	3 3/4"
Speedometer	3 3/8"	3 3/4"
Other Instruments	2 1/16"	2 3/8"

Color Codes	
Dial	 BK
Rim	 BK  PSS

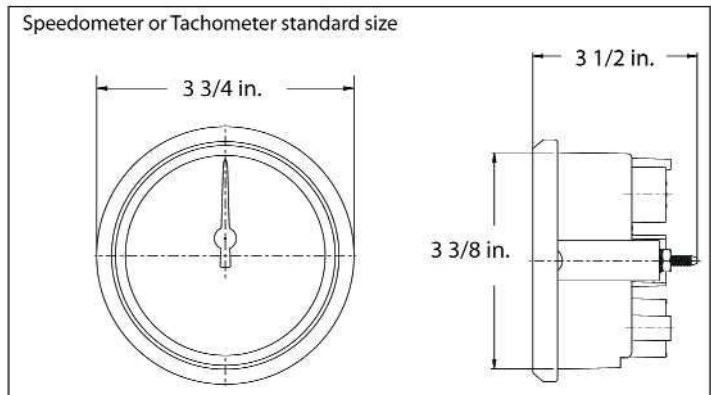

# Industrial Series Gauges

## Gas Tachometers



6,000 RPM



8,000 RPM



10,000 RPM



12,000 RPM

Tachometers- Gas			
Description	Part Number		Requires
	black/black	black/stainless	
6,000 RPM	DCS6000BKBK	DCS6000BKPSS	DCH Harness
8,000 RPM	DCS8000BKBK	DCS8000BKPSS	DCH Harness
10,000 RPM	DCS10000BKBK	DCS10000BKPSS	DCH Harness
12,000 RPM	DC12000BKBK	DC12000BKPSS	DCH Harness
DCH Harness 12V			DCH
DCH Harness 24V, used to converts to a 24V			DCH24
DCH Harness with Tach Filter- 12V reduces needle spikes from noisy ignitions			DCTFH
Note: Industrial tachs work on 4, 6, & 8 cylinder V-10 & Merc O/B 6 pulse/12 pole			

## Diesel Tachometers



4,000 RPM

Tachometers- Diesel 4000 RPM			
Description	Part Number		Requires
	black/black	black/stainless	
alt driven	DC4000DABKBK	DC4000DABKPSS	DCH Harness
mag probe driven	DC4000MPDBKBK	DC4000MPDBKPSS	DCH Harness
mechanical signal generator driven	DC4000MSGDBKBK	DC4000MSGDBKPSS	DCH Harness
DCH Harness 12V			DCH
DCH Harness 24V, used to converts to a 24V			DCH24
DCH Harness with Tach Filter- 12V reduces needle spikes from noisy ignitions			DCTFH
All three diesel tachs have the same dial graphics.			

## GPS Speedometers - With Recall

Livorsi GPS Speedometers require a NMEA 0183 antenna/receiver.



50 MPH



80 MPH



100 MPH



120 MPH



140 MPH



160 MPH



180 MPH





GPSSQ3 antenna

- Mounts with a 1/4" screw
- Dimensions:  
2 3/4" L x 2 3/8" W x 7/8" H

cutout size	overall size
3 3/8"	3 3/4"

### Color Codes

Dial		BK
Rim		BK
		PSS

Description	Part Number		Notes
	black/black	black/stainless	
50 MPH	GPSS50BKBK	GPSS50BKPSS	For a GPS Kit, add the letter "K" after the MPH.  Kit includes: - speedometer - antenna - memory recall - harness
80 MPH	GPSS80BKBK	GPSS80BKPSS	
100 MPH	GPSS100BKBK	GPSS100BKPSS	
120 MPH	GPSS120BKBK	GPSS120BKPSS	
140 MPH	GPSS140BKBK	GPSS140BKPSS	
160 MPH	GPSS160BKBK	GPSS160BKPSS	
180 MPH	GPSS180BKBK	GPSS180BKPSS	
GPS antenna	GPSSQ3		

Note: All GPS speedometers require a NMEA0183 compliant antenna/receiver.

# Industrial Series Gauges

## Mechanical Gauges

Description	Part Number		Requires
	black/black	black/stainless	
Boost 0-35 PSI	DCSMB35BKBK	DCSMB35BKPSS	hose kit
Fuel Pressure 0-15 PSI	DCSMFPBKBK	DCSMFPBKPSS	see page 35 for stainless hoses
Fuel Pressure 0-100 PSI	DCSMFP100BKBK	DCSMFP100BKPSS	
Oil Pressure 0-100 PSI	DCSMOPBKBK	DCSMOPBKPSS	hose kit
Vacuum/Boost 30 in hg/boost20	DCSMVBBKBK	DCSMVBBKPSS	hose kit
Water Pressure 0-35 PSI	DCSMWPBKBK	DCSMWPBKPSS	hose kit
Water Pressure 0-60 PSI	DCSMWP60BKBK	DCSMWP60BKPSS	hose kit
Hose Kits - not to be used with fuel			
10 feet of hose and fittings	HKA		
25 feet of hose and fittings	HK		

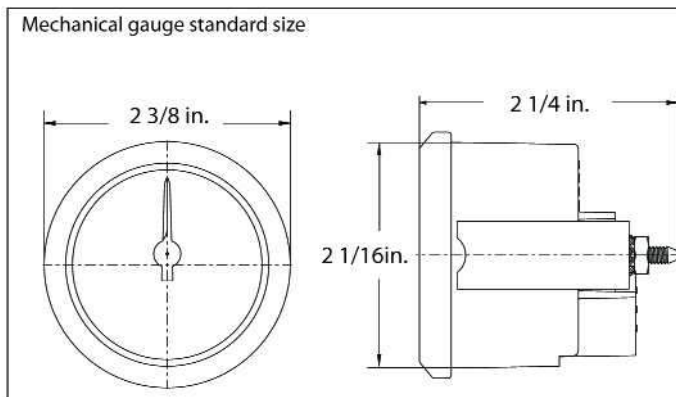

boost 0-35 PSI



fuel pressure 0-15 PSI



fuel pressure 0-100 PSI



oil pressure 0-100 PSI



vacuum boost



water pressure 0-35 PSI



water pressure 0-60 PSI

## Gauge Hardware

**4 Pin Connector & Wire Harness**  
 - 18 inches in length  
 - Pre-assembled and labeled

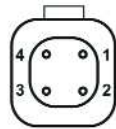

Pin # 1 = BLUE 12v+ illumination  
 Pin # 2 = VIOLET 12v+ ignition power  
 Pin # 3 = BLACK engine or battery ground  
 Pin # 4 = GREEN signal from sender

DCH Harness	
12 volt system	DCH
24 volt system	DCH24
12 volts w/ tach filter	DCTFH

Livorsi can provide you with the necessary parts to build your own Deutsch harnesses.

Example:

Parts needed to build a complete DCH connector harness:

- A. (1)- 4 pin connector plug
- B. (1)- 4 pin wedge lock
- C. Appropriate contacts for connectors

Connector Parts	
Description	Part Number
2 Pin - mechanical lights	
2 pin connector plug	DC2CPLUG
2 pin connector wedge lock	DC2CWL
4 Pin - electrical gauges	
4 pin connector plug	DC4CPLUG
4 pin connector wedge lock	DC4CWL
8 Pin - power distribution	
8 pin connector plug	DC8CPLUG
8 pin connector wedge lock	DC8CWL
12 Pin - power distribution	
12 pin connector plug	DC12CPLUG
12 pin connector wedge lock	DC12CWL
dummy plug	DCDP
contacts for 16 gauge wire	DCC1416
Hand Crimper	DCHCS

Description	Part Number
<b>Senders</b>	
Fuel Pressure 0-60 PSI / 0-90 PSI	GSFP60/90
Fuel & Water Pressure 0-15 PSI	GSFP/WP
Isolated Ground for Water Temperature	GSWT1/8I
Oil Pressure 0-80 PSI	GSOP80
Oil Pressure 0-100 PSI	GSOP
Oil / Water Temperature 100-320°F Water Temperature 100-250°F 1/8" thread	GSOT1/8
Pressure 400 PSI	GSP400
Water Temperature- Merc OB Kit	GSWTM
Water Temperature 100-280°F 1/8" thread	GSWT1/8
Bushing Kit 1 /4", 3/8" and 1/2" fittings	GSBKK1
<b>Memory Tach Recall</b> includes black box, switch plate, switch and boot	
recall with black switch plate	MTRBK
recall with white switch plate	MTRW
<b>Hose Kit for Mechanical Gauges</b> not to be used with fuel 1/8 in ID	
10 feet of hose and fittings	HKA
25 feet of hose and fittings	HK

See page 45 for fuel level & water level senders.

# Industrial Series Gauges

## Electric Gauges



These electric gauges require the use of a four pin Deutsch connector wire harness (unless otherwise noted) that we call a DCH harness.

We offer these harnesses pre-assembled for 12V or 24V systems, with labeled wire leads 18 inches in length. Please specify when ordering.

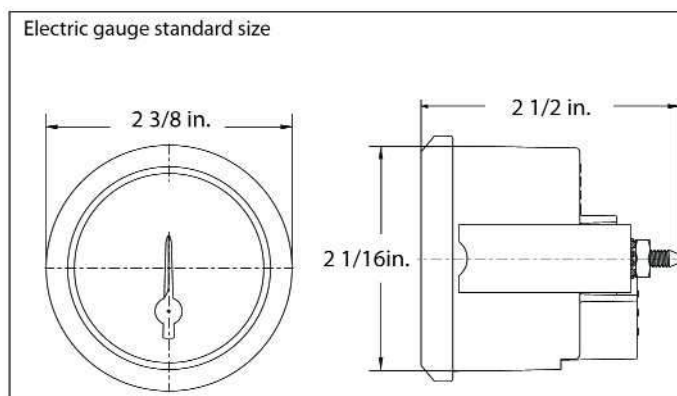

Description	Part Number		Requires
	black/black	black/stainless	
Boost 60 PSI	DCSB60BKBK	DCSB60BKPSS	-
Fuel Level 0-90 OHMS	DCSFLGMBKBK	DCSFLGMBKPSS	DCH/DCH24, fuel level sender
Fuel Level 240-33 OHMS	DCSFLBKBK	DCSFLBKPSS	DCH/DCH24, fuel level sender
Fuel Pressure 0-15 PSI	DCSFPBKBK	DCSFPBKPSS	DCH/DCH24, GSFP/WP
Fuel Pressure 0-90 PSI	DCSFP90BKBK	DCSFP90BKPSS	DCH/DCH24, GSFP60/90
Hourmeter	HMBKBK	HMBKPSS	-
Oil Pressure 0-80 PSI	DCSOP80BKBK	DCSOP80BKPSS	DCH/DCH24, GSOP80
Oil Temperature 140-340° F	DCSOTBKBK	DCSOTBKPSS	DCH/DCH24, GSOT1/8
Transmission Temp 140-340° F	DCSTTBKBK	DCSTTBKPSS	DCH/DCH24, GSOT1/8
Trimmer Merc & Yamaha 10-90 OHMS	DCSTMMBKBK	DCSTMMBKPSS	DCH/DCH24
Trimmer OMC 88-1 OHMS	DCSTMOBKBK	DCSTMOBKPSS	DCH/DCH24
Voltmeter 8-18V	DCSVMBKBK	DCSVMBKPSS	DCH/DCH24
Voltmeter 22-32V	DCSVM24BKBK	DCSVM24BKPSS	DCH/DCH24
Water Level	DCSWLBKBK	DCSWLBKPSS	DCH/DCH24, water level sender
Water Temperature 100-250° F	DCSWTABKBK	DCSWTABKPSS	DCH/DCH24, GSOT1/8
Water Temperature 100-280° F	DCSWTBKBK	DCSWTBKPSS	DCH/DCH24, GSWT1/8
DCH Harnesses- pre-assembled			
12 volt system, 18 inch leads	DCH		
24 volt system, 18 inch leads	DCH24		



Color Codes	
Dial	 BK
Rim	 BK  PSS



# Industrial Series Gauges



boost 60 PSI



fuel level



fuel pressure 0-15 PSI



fuel pressure 0-90 PSI



hourmeter



oil pressure 0-80 PSI



oil temperature 140-340° F



transmission temp 140-340° F



trimmer



voltmeter 8-18 V



voltmeter 22-32 V



water level



water temperature 100-250° F



water temperature 100-280° F

Specify 12V or 24V

# Vantage View®



For SmartCraft®,  
NMEA 2000®,  
SAE J1939 and  
GM MEFI engines

The Vantage View® system comprises of a Master Tachometer that reads information directly from the ECM/ECU. The Master Tachometer contains a LCD screen in which the user is able to view the performance data, Faults and Warnings of the boat or vehicle. All Vantage View® gauges utilize 270° digital stepper motors that accurately display data in real time. While these instruments are digital, they were designed with the traditional styling of analog gauges. Fluorescent fade resistant pointers and large bold graphics make these instruments easy to ready at a glance.

User programmable warning alarms, simplified rigging and rugged construction makes this line of instruments an exceptional tool for monitoring the performance of a vehicle, workboat or powerboat.

## Faults and Warnings

Vantage View® alerts you of Faults and Warnings with blinking icons on the Master Tachometer LCD screen. Faults are a problem reported by the ECM/ECU that warrants stopping the engine. Warnings alert you of potential problems as reported by the ECM/ECU.

## Speed

Vantage View® reads both CAN (NMEA 2000® and SAE J1939) and serial (NMEA 0183) based speed inputs.

## Fuel Tank and Engine Trim Calibration

The newest feature of the Vantage View® system is the ability to calibrate the fuel tank and engine trim, ensuring utmost accuracy. The Master Tachometer can monitor up to two fuel tanks with the option to use an analog signal or CAN Bus information. The Engine Trim feature also allows for one analog or one CAN Bus signal.

## Programmable Alarms

In addition to factory set Fault and Warnings, users can tailor up to 15 alarms to their individual needs. When triggered, pop-up alerts appear on the LCD screen and the bright LED warning light illuminates on the corresponding slave gauge.

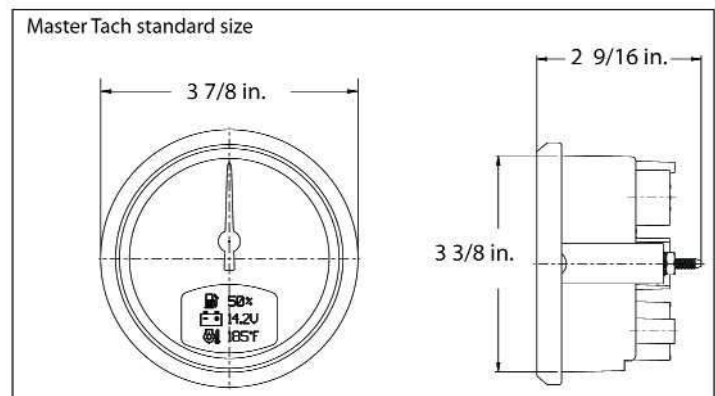

Tachometers



VJS4KBKPLR



VJS7KPLPLR



VJS7KBKPSR

Each engine requires its own Master Tachometer

- LCD displays up to 10,000 RPM
- Up to 6 slave gauges may be daisy chained to the Master Tachometer
- Marine configured tachs display “Total Hours”
- Automotive/industrial configured tachs display “Total Miles”
- Have the ability to record and reset three trip logs
- The user can set up 10 parameters of their choice to display in the main screens. Choose between single or three parameter display.

Menu navigation requires the use of either a control pod (controls up to 4 engines) or the VV switch control module, see page 21 for part numbers.

Compatible with NMEA 2000®, J1939 & MEF14 protocol

Description	Part Number	Requires
4000 RPM black	VJS4KBK	Corresponding Master Harness, slave harnesses and a control pod or switch assembly
4000 RPM platinum	VJS4KPL	
7000 RPM black	VJS7KBK	
7000 RPM platinum	VJS7KPL	



Control Pod twin engine

Compatible with SmartCraft® protocol

Description	Part Number	Requires
4000 RPM platinum	VSCS4KPL	Corresponding Master Harness, slave harnesses and a control pod or switch assembly
7000 RPM platinum	VSCS7KPL	

Color Codes	
Dial	PL (Platinum) BK (Black)
Rim	BKR (Black Rim) PLR (Platinum Rim) PSR (Platinum Rim)



# Vantage View®

## Speedometers



VJS60PLPLR



VJS80PLBKR



VJS100BKPSR

Color Codes		
Dial	PL	BK
Rim	BKR	PLR
	PLR	PSR



VJS120PLPSR



VJS160BKPSR



GPSRAQ3VV antenna  
 - Mounts with a 1/4" screw  
 - Dimensions:  
 2 3/4" L x 2 3/8" W x 7/8" H

- Vantage View® reads both CAN and GPS based speed inputs.
- CAN based inputs include water or ground speed references.
- Using the GPS based input requires the device to be NMEA 0183 compliant.
- If more than one speed source exists, users can view all speed data on the Master Tachometer LCD by selecting View Parm's from the Main Menu.

Note: If using the GPS input option, Vantage View® requires the use of Livorsi GPS antenna part number: GPSRAQ3VV. Other GPS antenna models may not work with Vantage View®.

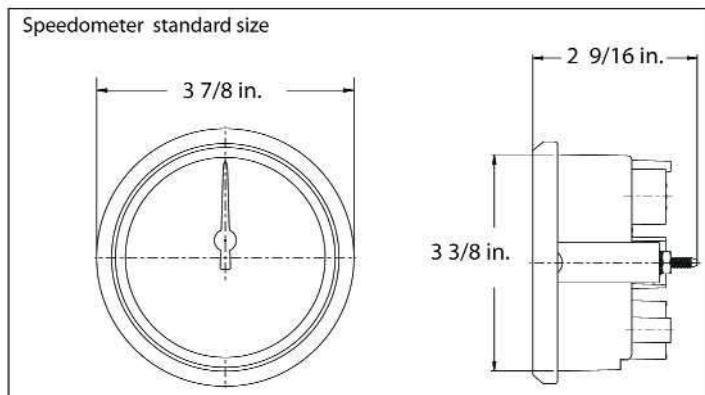

Description	Base Part Number
60 MPH	VJS60
80 MPH	VJS80
100 MPH	VJS100 †
120 MPH	VJS120
160 MPH	VJS160 †
GPS Antenna	
1 second (1Hz)	GPSRAQ3VV
† Note: Available with a black dial	

## FWA Gauge- Fault Warning Alarm







This gauge provides five discrete illuminated visual indicators and multiple outputs. Outputs include a dedicated audible alarm and one set of relay output contacts for secondary alarms or additional engine protection devices.

This FWA gauge is needed in order for Vantage View® to receive built in Faults and Warnings from Cummins Diesel engines when a Diesel View display is not present.

FWA gauge will work on all engine protocols except for Mercury Gas SmartCraft® engines.

Available with a black dial only. 2 1/8" cutout

Description	Part Number
fwa gauge	VJSFWABK + rim color

Color Codes	
Dial	 BK
Rim	 BKR  PLR  PSR

## VV Switch Control Module

- One assembly needed per engine
- Requires two 1/2 in. cutout for toggle switches

VVSAW assembly includes:

- Two switches & two boots
- DCC contacts for easy installation

Description	Part Number
switch control module	VVSAW
mode switch only	TSMF
up/down switch only	TSMFM
black switch boot	TSRBBK
plate only (2 3/4 in diam.)	PSSP + color



## Control Pod

- Control up to 4 Master Tachometers with one pod
- Uses waterproof momentary buttons
- Twin, triple and quad control pods have a polished selector knob to toggle between Master Tachometers

Description	Part Number	
	Black	Platinum
single engine	VVCPSABK	VVCPSAPL
twin engine	VVCPTABK	VVCPTAPL
triple engine	VVCPTRABK	VVCPTRAPL
quad engine	VVCPCQABK	VVCPCQAPL



Control Pod twin engine

# Vantage View®

## Slave Gauges

- Slave gauges must be connected to the Master Tachometer via the slave harness daisy chain
- 270 degree sweep with digital stepper motors
- LED warning lights illuminate when programmed alarms are triggered (setup through the Master Tachometer)
- Fluorescent orange pointers
- Back lit with red LED lighting

Compatible with NMEA 2000®, SmartCraft®, SAE J1939	
Description	Part Number
boost 0-35 PSI †	VJSB
fuel level 1 †	VJSFL1
fuel pressure 90 PSI †	VJSFP90
oil level 1	VJSOL1
oil pressure 0-80 PSI †	VJSOP
oil temperature 0-280°F †	VJSOT
trim drive port (left) †	VJSTDP
trim drive stbd (right) †	VJSTDS
voltmeter 10-16V †	VJSVM
water pressure 30 PSI	VJSWP30
water pressure 60 PSI	VJSWP60
water temperature 100-240°F †	VJSWT

Note: † Available with a black dial

Additional gauges available for SmartCraft® only	
Description	Part Number
fuel level 2 †	VJSFL2
oil level 2	VJSOL2

Slave Gauges- NMEA 2000® - Ilmor compliant	
Description	Part Number
voltmeter- alternator 10-16V †	VVNISVMA
water pressure 30 PSI †	VNSWP30C

Note: † Available with a black dial

Color Codes	
Dial	<div style="display: flex; align-items: center; gap: 10px;"> <div style="text-align: center;"> <span style="background-color: #cccccc; border-radius: 50%; width: 15px; height: 15px; margin: 0 auto;"></span> PL         </div> <div style="text-align: center;"> <span style="background-color: #000000; border-radius: 50%; width: 15px; height: 15px; margin: 0 auto;"></span> BK         </div> </div>
Rim	<div style="display: flex; align-items: center; gap: 10px;"> <div style="text-align: center;"> <span style="background-color: #000000; padding: 2px 5px; font-weight: bold;">BKR</span> </div> <div style="text-align: center;"> <span style="background-color: #cccccc; padding: 2px 5px; font-weight: bold;">PLR</span> </div> <div style="text-align: center;"> <span style="background-color: #cccccc; padding: 2px 5px; font-weight: bold;">PSR</span> </div> </div>

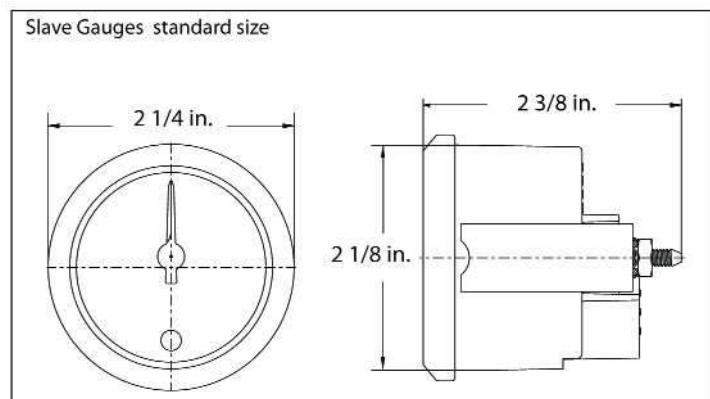
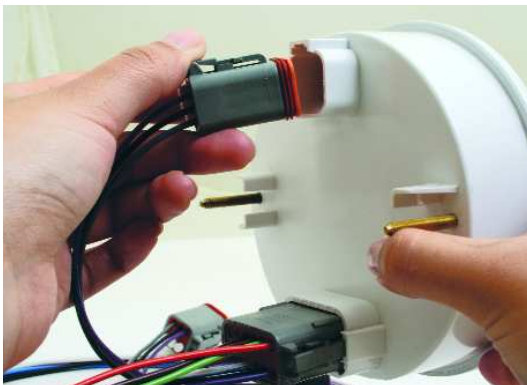

# Vantage View®



boost 0-35 PSI



fuel level 1



fuel level 2



fuel pressure 0-90 PSI



oil level 1



oil level 2



oil pressure 0-80 PSI



oil temperature 100-280° F



trim drive port (left)



trim drive starboard (right)



voltmeter 10-16



water pressure 0-30 PSI



water pressure 0-60 PSI



water temperature 100-240° F

See page 27  
for Slave  
Harnesses

## Harnesses

SAE J1939/Indmar Master Harness  
length: 36 in. ± .5 in.

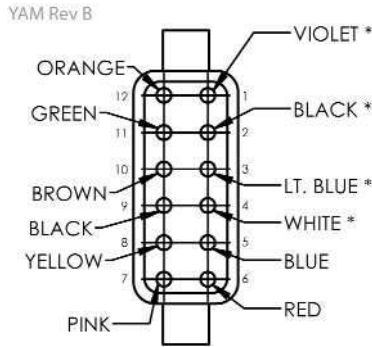

Part Number		VVMHJI
Wire Label		
#	Color	Label
1	Violet	Switched Positive
2	Black	Ground
3	Lt. Blue	CAN L
4	White	CAN H
5	Blue	Lighting
6	Red	Battery
7	Pink	Analog
8	Yellow	NMEA 0183
9-12	-	to amp connector

SmartCraft® Master Harness  
length: 36 in. ± .5 in.

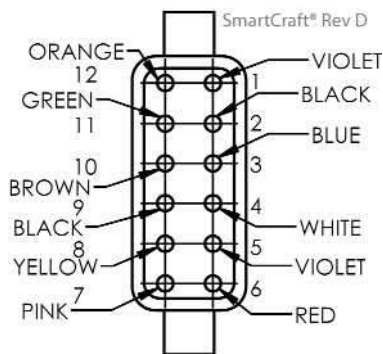

Part Number		VVMHSC
Wire Label		
#	Color	Label
7	Pink	Analog
8	Yellow	NMEA 0183

NMEA 2000® Micro C Female Master Harness  
length: 36 in. ± .5 in.

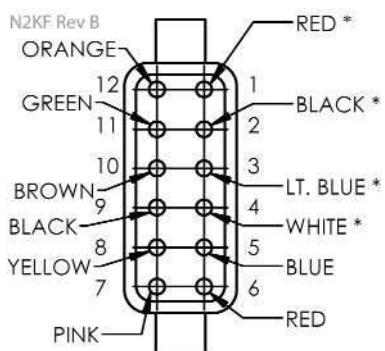

Part Number		VVMHN2KF
Wire Label		
#	Color	Label
5	Blue	Lighting
6	Red	Battery
7	Pink	Analog
8	Yellow	NMEA 0183



Harnesses

NMEA 2000® Micro C Male Master Harness  
length: 36 in. ± .5 in.

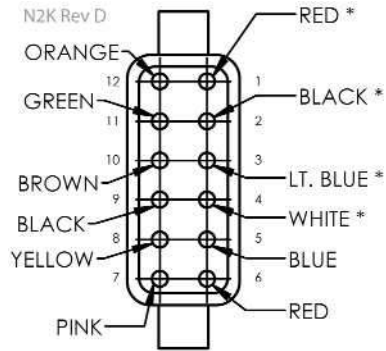

Part Number		VVMHN2K
Wire Label		
#	Color	Label
5	Blue	Lighting
6	Red	Battery
7	Pink	Analog
8	Yellow	NMEA 0183

Ilmor Micro C Male Master Harness  
length: 36 in. ± .5 in.

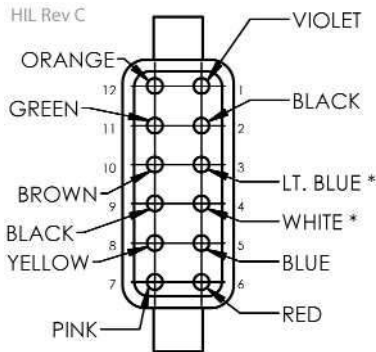

Part Number		VVMHIL
Wire Label		
#	Color	Label
1	Violet	Switched Positive
2	Black	Ground
5	Blue	Lighting
6	Red	Battery
7	Pink	Analog
8	Yellow	NMEA 0183

Slave Harnesses



Long Slave Harness		
Description	Length	Part Number
2 gauge	27 1/2 in.	VVSH2L
4 gauge	53 1/2 in.	VVSH4L
6 gauge	78 1/2 in.	VVSH6L

Short Slave Harness		
Description	Length	Part Number
2 gauge	17 in.	VVSH2S
4 gauge	37 1/2 in.	VVSH4S
6 gauge	54 1/2 in.	VVSH6S

Analog Input Parameters Table			
Parameter	Range	Analog Input	LCD Display Name
Block Pressure	0-200 PSI	240-33Ω/10-180Ω	Block Press
Boost Pressure	0-200 PSI	240-33Ω/10-180Ω	Boost Press
Brake Application Pressure	0-200 PSI	240-33Ω/10-180Ω	Brake Appl Pr
Brake Primary Pressure	0-200 PSI	240-33Ω/10-180Ω	Brake Prim Pr
Brake Secondary Pressure	0-200 PSI	240-33Ω/10-180Ω	Brake Sec Prs
Coolant Level	0-100%	240-33Ω/10-180Ω/0-90Ω	Coolant Level
Engine Oil Level	0-100%	240-33Ω/10-180Ω/0-90Ω	Eng Oil Lvl
Engine Oil Pressure	0-200 PSI	240-33Ω/10-180Ω	Eng Oil Press
Front Air Pressure	0-150 PSI	240-33Ω/10-180Ω/0-90Ω	Front Air
Fresh Water Level	0-100%	240-33Ω/10-180Ω/0-90Ω	Fresh Wat Lvl
Fuel Delivery Pressure	0-200 PSI	240-33Ω/10-180Ω	Fuel Press
Fuel Level 1	0-100%	240-33Ω/10-180Ω/0-90Ω/Centroid 3	Fuel Level 1
Fuel Level 2	0-100%	240-33Ω/10-180Ω/0-90Ω/Centroid 3	Fuel Level 2
Generic Level	0-100%	240-33Ω/10-180Ω/0-90Ω	Misc Level
Generic Pressure	0-400 PSI	240-33Ω/10-180Ω	Misc Pressure
Hydraulic Oil Level	0-100%	240-33Ω/10-180Ω/0-90Ω	Hydr Oil Lvl
Hydraulic Oil Pressure	0-200 PSI	240-33Ω/10-180Ω	Hydr Oil Pres
Inside Temperature	-4 - 104 °C	10K Thermistor	Inside Air Tm
Outside Temperature	-4 - 104 °C	10K Thermistor	Outsde Air Tm
Rear Air Pressure	0-150 PSI	240-33Ω/10-180Ω/0-90Ω	Rear Air
Rudder Angle	-100° - 100°	240-33Ω/10-180Ω/0-90Ω	Rudder Angle
Steering Angle	-100° - 100°	240-33Ω/10-180Ω/0-90Ω	Steer Angle
Transmission Oil Level	0-100%	240-33Ω/10-180Ω/0-90Ω	Trns Oil Lvl
Transmission Oil Pressure	0-400 PSI	240-33Ω/10-180Ω	Trns Oil Pres
Trim	0-100%	240-33Ω/10-180Ω/ 0-90Ω/167-10Ω	Trim Position
Washer Fluid Level	0-100%	240-33Ω/10-180Ω/0-90Ω	Washer Level
Waste Water Level	0-100%	240-33Ω/10-180Ω/0-90Ω	Waste Wat Lvl
Water Temperature	-4 - 104 °C	10K Thermistor	Water Temp
GPS Compass	0-360°	NMEA 0183	GPS Compass
GPS Heading	0-360°	NMEA 0183	GPS Heading
GPS Speed	0-200 MPH	NMEA 0183	GPS Speed
Latitude	-180° - 180°	NMEA 0183	Latitude
Longitude	-180° - 180°	NMEA 0183	Longitude
Speed (Water Reference)	0-200 MPH	NMEA 0183	Water Speed
Water Depth	0-999'	NMEA 0183	Water Depth
Water Temperature	-4 - 104 °C	NMEA 0183	Water Temp

Faults or Warnings		
Description	Faults or Warnings	
Warning Over Heat	Over-heat	W
Warning Low Oil Pressure	Low Oil Press	W
Warning Low Voltage	Low Voltage	W
Warning High Voltage	High Voltage	W
Warning Over Speed	Over Speed	W
Warning Water in Fuel	Fuel	W
Warning Guardian Active	Guard Active	W
Warning Check Engine	Check Engine	W
Oil Fault	Oil	F
Guardian/Check Engine Fault	Guard/Ck Eng	F
CAN Fault	CAN Bus	F
Water in Fuel Fault	Fuel	F
Voltage Fault	Voltage	F
Coolant Temperature Fault	Coolant Temp	F



**SAE J1939**

**MEFI4A/B**

**MEFI5**

**MEFI6**

**MoTeC**

**OBDII**

**NOTE:**

Each engine has its own factory set Warnings and/or Faults. These cannot be changed.

A Warning or Fault icon will appear on the LCD screen to alert the user of a potentially serious problem with the engine.

# Mercury® MercMonitor

MercMonitor featuring the Mercury® Gateway converts SmartCraft® engine and system data to NMEA 2000®/J1939 protocol for use on NMEA 2000®/J1939 multi-function displays and gauges.



Engines  
NMEA 2000®  
Outboards & Sterndrives



Systems  
Trim Tabs &  
Depth Sounders



GPS  
Chartplotters  
Pucks/Receivers



Gauges  
NMEA 2000®  
compatible



Displays  
NMEA 2000®  
compatible

## ECO-Screen



Not Optimized



Optimized

The ECO-Screen feature constantly monitors engine RPM, boat speed, fuel consumption and engine trim† to automatically calculate and guide you to your best fuel economy settings.

No calibration required.

NMEA 2000®/J1939† Out/In Supported	Data Level
RPM	1 · 2 · 3
Voltage	1 · 2 · 3
Oil Pressure	1 · 2 · 3
Coolant Temperature	1 · 2 · 3
Tank Level Fuel	1 · 2 · 3
Trim Position	1 · 2 · 3
Water Pressure	1 · 2 · 3
GPS Speed/COG/ Lat-Lon (in only)	1 · 2 · 3
Check Engine Alarm	1 · 2 · 3
Fuel Flow	2 · 3
Engine Hours	2 · 3
Boost Pressure <sup>5</sup>	2 · 3
Oil Temperature <sup>5</sup>	2 · 3

5 Available on Mercury Verado  
† J1939 limits signals and data levels

NMEA 2000® Only Out/In Supported	Data Level
Multiple Tank Levels	2 · 3
Tabs	2 · 3
Depth	2 · 3
Sea Water Temp	2 · 3
Paddle speed	2 · 3
Pitot Speed	2 · 3
Rudder Angle	3
Gear Pressure <sup>6</sup>	3
Gear Temp <sup>6</sup>	3
Fuel Pressure	3

6 Available on Cummins MerCruiser Diesel Engines  
†† Digital Trim sender required for full functionality.

Cutout: 3 3/8"

Overall: 3 3/4"

Merc Monitor Kits		Part Number
Data Level 1	Single Engine- Troll Control- NMEA 2000	879337K51
Data Level 2	Single Engine- RPM SmartTow- NMEA 2000	879338K51
Data Level 3	Multi Engine- RPM SmartTow- NMEA 2000	879337K52
Data Level 3	Multi Engine- SmartTow Pro- NMEA 2000	879339K51

NOTE: This MercMonitor is needed to transmit SmartCraft® information to our Adjustable Position LED Indicators. See page 36

# Mercury® Gateways

The new Mercury Gateway converts engine and system data to NMEA 2000® protocol for use on non-Mercury gauges and displays such as our Adjustable Position LED Indicators. See page 36



Included with Gateway:

- Module,
- 4 mounting screws,
- 2 zip ties
- N2K Tee
- installation instructions

Note: Gateway will not provide operation power for devices on the NMEA 2000® network.

Description	Part Number
single engine gateway	8M0065207
multi-engine gateway	8M0065208

Livorsi provides an array of NMEA 2000® harnessing and accessories, see page 42

Signal	J1939 PGN	Mode
RPM	61444 / 0xF004	TX
Voltage	65271 / 0xFE7F	TX
Coolant Temperature	65262 / 0xFEE4	TX
Fuel Level	65276 / 0xFEFC	TX
Fuel Flow	65266 / 0xFE72	TX
Oil Pressure	65263 / 0xFEEF	TX
Boost Pressure	65270 / 0xFE76	TX
Engine Hours	65253 / 0xFEE5	TX
Manufacturer ID	61182 / 0xEEFE	TX
Alarm Data	65226 / 0xFECA	TX

Signal	NMEA2K PGN	Mode
RPM	127498 / 0x1F20A	RX / TX
Coolant Pressure	127489 / 0x1F201	RX / TX
Speed	128259 / 0x1F503	RX / TX
RPM	127488 / 0x1F200	RX / TX
Voltage	127489 / 0x1F201	RX / TX
Coolant Temperature	127489 / 0x1F201	RX / TX
Fuel Pressure	127489 / 0x1F201	RX / TX
Fuel Level	127505 / 0x1F211	RX / TX
Fuel Tank Size	127505 / 0x1F211	RX / TX
Fuel Flow	127489 / 0x1F201	RX / TX
Oil Pressure	127489 / 0x1F201	RX / TX
Oil Temperature	127489 / 0x1F201	RX / TX
Gear Temp	127493 / 0x1F205	RX / TX
Gear Pressure	127493 / 0x1F205	RX / TX
Boost Pressure	127488 / 0x1F200	RX / TX
Trim Position	127488 / 0x1F200	RX / TX
Rudder Angle	127245 / 0x1F10D	RX / TX
Depth	128267 / 0x1F50B	RX / TX
Depth Offset	128267 / 0x1F50B	RX / TX
Sea Water Temp	130310 / 0x1FD06	RX / TX
Engine hours	127489 / 0x1F201	RX / TX
Manufacturer ID	060928 / 0xEE00	RX / TX
Alarm Data	127489 / 0x1F201	RX / TX
Tabs	130576 / 0x1FE10	RX / TX
Battery	127508 / 0x1F214	RX / TX
ISO Acknowledge	059392 / 0x0E800	RX / TX
Course Over Ground	129026 / 0x9F802	RX / TX
Speed Over Ground	129026 / 0x9F802	RX / TX
GPS Position	129025 / 0x1F801	RX / TX
Address Claim	060928 / 0xEE00	RX / TX
Product Info	126996 / 0x1F014	RX / TX

# Livorsi Data Gateway

With the Livorsi Data Gateway you can import CAN (Controller Area Network) MEFI ECU engine data to a NMEA 2000® device and display engine data. See following pages for information transmitted. The engine info that displays is the same data that your engine builder or tuner can pull up on their laptops using advanced software. Livorsi's Data Gateway simply plugs into your NMEA2000 device from the gateway using a standard NMEA 2000® Tee connector. On the engine side it will interface by CAN+ / CAN- wires to gather the info and send it off to a screen and or gauges.

Use the gateway on an older engine to convert the data into NMEA 2000® language for use with Vantage View gauges or a NMEA 2000® navigation device such as Garmin, Lowrance or Raymarine. Please note that engine data is only transmitted if there is a sensor to support it.

Use this gateway to translate info onto our state of the art Vantage View Gauges on page 18

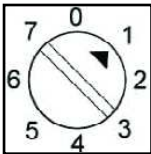

The selection switch is used to select the engine instance when multiple engines are used, as well as to select whether the engine is naturally aspirated or boosted.

Description	Part Number
data gateway	MEFI4G
rigging kit	MEFI4RK

## Engine Configuration for MercMonitor, Mercury Gateway or the Livorsi Data Gateway

### Single Engine Configuration

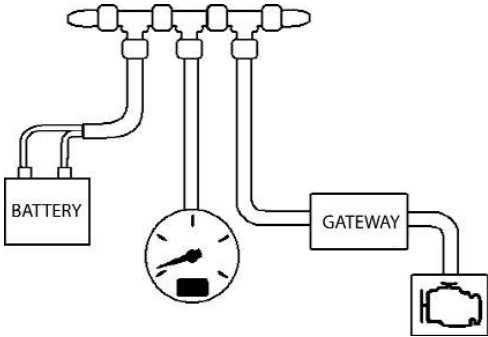

### Twin Engine Configuration

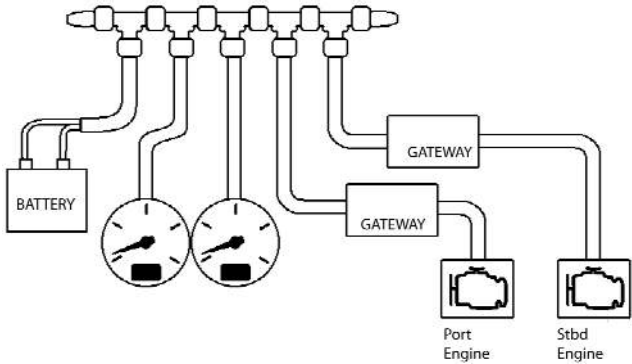

# Livorsi Data Gateway

NMEA 2000 Output Parameters				
Parameter	MEFI4A	MEFI4B	MEFI5/6 (J1939)	OBDII
Air Temperature	X	X	X	X
Barometric Pressure	X	X	X	X
Battery Potential	X	X	X	X
Boost Pressure	X	X	X	X
Engine Coolant Temperature	X	X	X	X
Engine Coolant Pressure	X	X	X	
Engine Fuel Rate	X	X	X	X
Engine Hourmeter	X	X	X	
Engine Inlet Air Temp				
Engine Percent Load	NA (EEC2) <sup>2</sup>	NA (EEC2) <sup>2</sup>	X1	X
Engine Oil Pressure	X	X	X	X
Engine Oil Temperature	X	X	X	X
Engine Speed	X	X	X	X
Engine Percent Torque	NA (EEC2) <sup>2</sup>	NA (EEC2) <sup>2</sup>		
Fuel Level				X
Fuel Pressure	NA (EFL/P1) <sup>2</sup>	NA (EFL/P1) <sup>2</sup>	X	X
Run Time Since Start				X
Throttle Position	NA (LFE) <sup>2</sup>	NA (LFE) <sup>2</sup>	X <sup>1</sup>	X
Vehicle Distance (Since DTC clear)				
Vessel Speed	X	X	NA (MEFI4B) <sup>2</sup>	X
Current Gear				
Engine Discrete Status:				
Check Engine	X	X		
Rev Limit Exceeded	X	X		
Low Oil Pressure	X			
Low System Voltage	X			
Low Oil Level	X			
General Warning 1	X			
General Warning 2	X			
Low Fuel Pressure	X			
Emergency Stop Mode	X			
Engine Over Temp	X			
SAE J1939 Output Parameters				
Parameter	MEFI4A	MEFI4B	MEFI5/6 (J1939)	OBDII
Air Temperature	X	X	X	X
Barometric Pressure	X	X	X	X
Battery Potential	X	X	X	X
Boost Pressure	X	X	X	X
Engine Coolant Temperature	X	X	X	X
Engine Coolant Pressure	X	X	X	
Engine Fuel Rate	X	X	X	X
Engine Hourmeter	X	X	X	
Engine Inlet Air Temp				X
Engine Percent Load	NA (EEC2) <sup>2</sup>	NA (EEC2) <sup>2</sup>	X	X
Engine Oil Pressure	X	X	X	X
Engine Oil Temperature	X	X	X	X
Engine Speed	X	X	X	X
Engine Percent Torque			X	
Fuel Level				X
Fuel Pressure	NA (EFL/P1) <sup>2</sup>	NA (EFL/P1) <sup>2</sup>	X	X
Run Time Since Start				N2K
Throttle Position	NA (LFE) <sup>2</sup>	NA (LFE) <sup>2</sup>	X	X
Vehicle Distance (Since DTC clear)				X
Vessel Speed	X	X	NA (MEFI4B) <sup>2</sup>	X
Current Gear				X

## Electronic Foot Pedal

- Currently designed to control the throttle on PCM and Marine Power engines.
- These pedals may be calibrated for MEFI5 and 6 engines. (call for details)
- This completely electronic design eliminates problematic cables from bow to stern.
- A sensor is used to send the position information from the pedal to the ECU on the engine.
- Fully sealed to IP68 specifications, this sensor is waterproof and highly durable.
- Plug and play waterproof Deutsch connectors make for a quick and easy installation.
- Solid rugged design, made of billet aluminum with an anodized finish to prevent corrosion.
- Aggressive anti-slip features are built right into pedal for confident non-slip throttling.
- Private Labeling available



Description	Part Number
Foot Pedal	EFP101
Harness Length	Part Number
12 feet	CHPCM12
15 feet	CHPCM15
23 feet	CHPCM23

# LED Pop Up Bow Light

- Port and starboard light in one housing
- Marine grade 316 stainless steel
- Folds down flush when closed
- USCG approved for 2 nautical miles
- LED lights stay cool to the touch
- Optional cup for water run-off
- Light with cup measures 3 1/4" deep
- Light has 3 1/2" diameter cutout



Description	Part Number
bow light	LEDPUBL
water run off cup	LEDPUBLWC



shown closed  
with optional cup

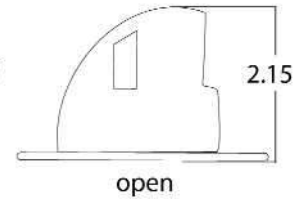
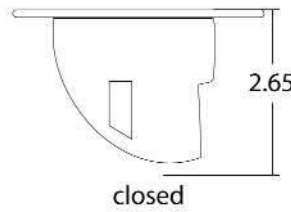
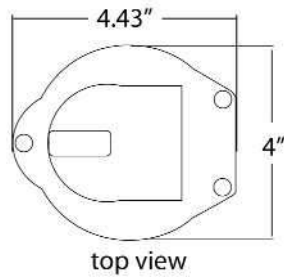

# LED Courtesy Lights

- Not certified for use as navigation lights
- Housing is machined from billet aluminum
- Environmentally sealed
- Bright LED can illuminate engine compartments



Description	Part Number
red	LEDR
green	LEDG
white	LEDW

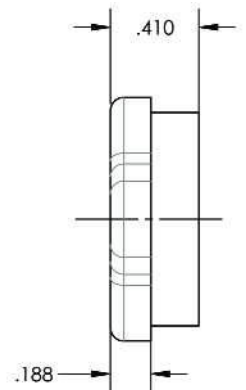
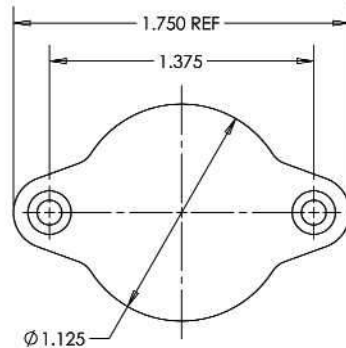
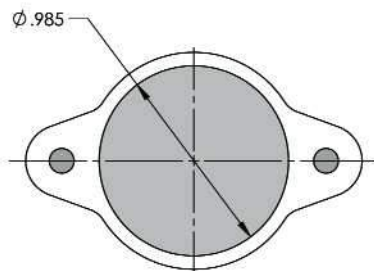



# LED Navigation Lights



These Livorsi LED nav lights only consume 1/10th of an amp at 14 volts. This means a longer life and less rigging time replacing lights. These lights are to be used on any vessel up to 65 feet and have a visibility of 2 nautical miles.

Designed to be mounted on a vertical surface, to allow the light pattern to be unobstructed from view.

- Visible for 2 nautical miles
- For use on boats up to 65 feet
- Marine grade 316 stainless steel
- Available for 12 or 24 volt systems
- Completely waterproof, environmentally sealed
- NMMA accepted
- USCG approved for 2 nautical miles
- Meets ABYC standards

Description	Part Number
port - red	LEDNL2R
starboard - green	LEDNL2G
adapter plate	LEDNLAP

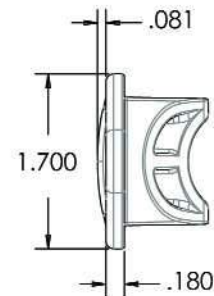
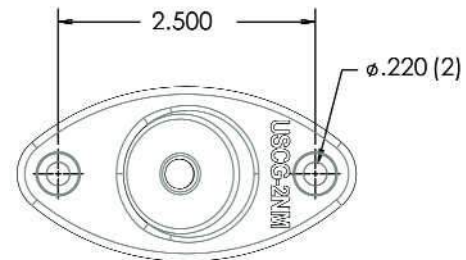
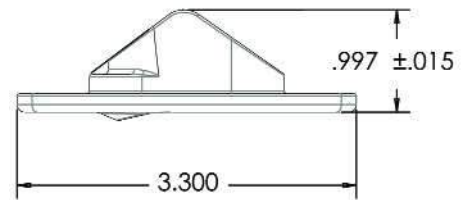

LEDNLAP  
8" L x 2 1/4" W x 1/8" thick

ABYC Section A-16: The starboard sidelight showing green, and the port sidelight showing red, from dead ahead to 22.5° abaf t the beam (90° + 22.5° + 1 12.5°) on their respective sides.

Mounting angle for navigation lights is 24° relative to centerline of boat.

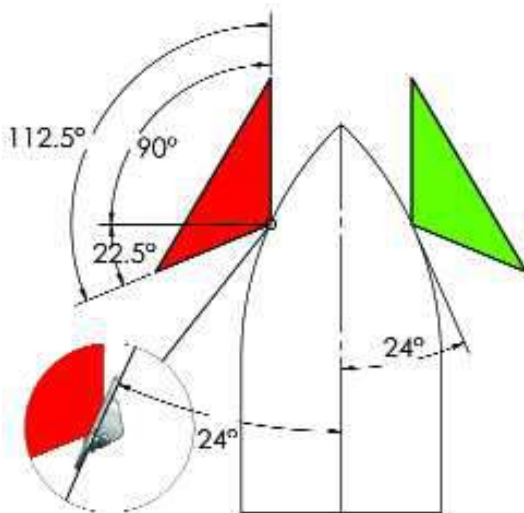

# Hydraulic Trim Tabs



- These heavy duty hydraulic trim tabs meet the demand of boats operating at high speeds or in rough water conditions.
- For boats from 25 to 40 feet
- Tabs incorporate a hinge constructed of extruded aluminum with a 1/2" stainless steel pin to provide unmatched strength and reliability even with large jet pumps being activated.
- Tabs are fabricated from stainless steel and billet aluminum which are hard-coat anodized for years of corrosion free operation.
- Accommodates a 12°,16° or 90° transoms, 12V or 24V systems



## Mounting Plate Dimensions

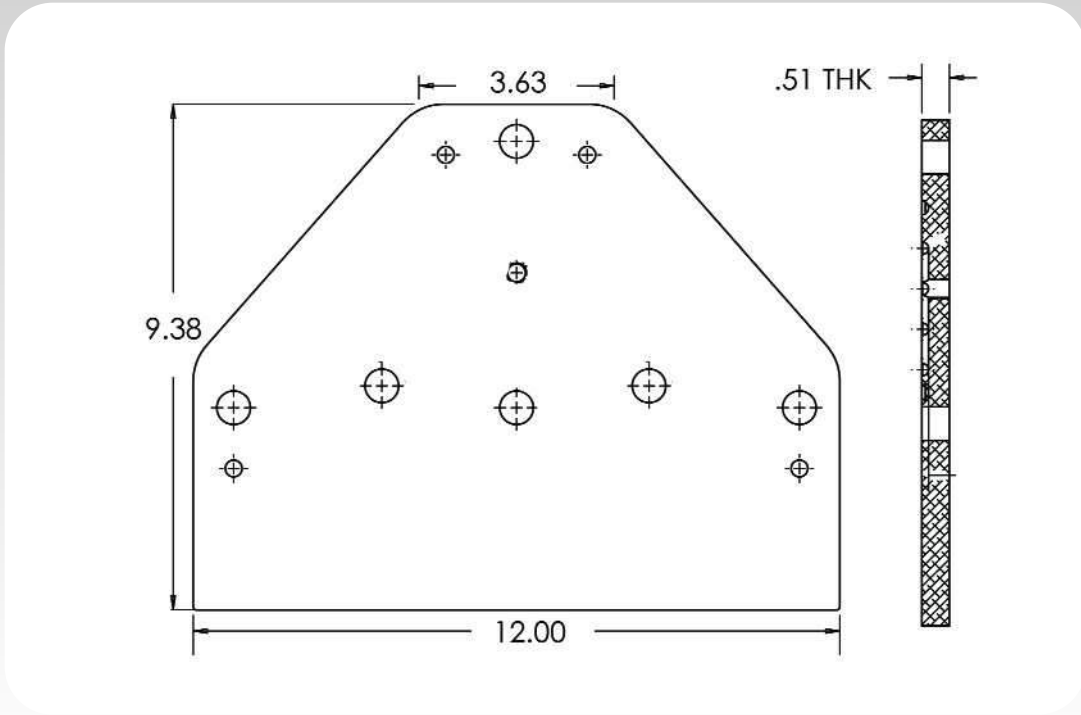

For Tab Indication, see page 47 for our Mechanical Indicators

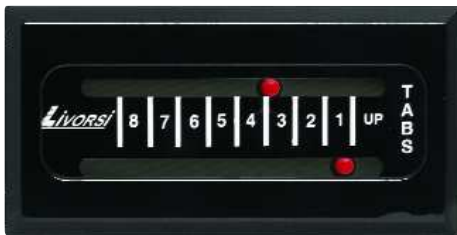

Trim Tab Kits Description	Part Number
24 volt system	MTK24V
12 volt system	MTK12V

Hoses For Trim Tab Kits		
Hose Description	Hose Part Number	Qty
30 inch	SSBH30IN	1
34 inch	SSBH34IN	1
60 inch	SSBH60IN	1
90 inch	SSBH90IN	1
21 feet	SSBH21FT	1
26 feet	SSBH26FT	1

# Adjustable Position LED Indicators

Displays position for tabs, drives, jackplates, rudder indicator, fuel and water level

Compatible With:

- NMEA 2000® (Rx + Tx) Devices
- J1939 (Rx + Tx) Devices
- Resistive Sensors (ohms)
- SmartCraft® (with Gateway)
- 0-5 Volt Sensors

The LED position indicators eliminate the need for mechanical 33C cables which are typically used for drive and tab indication. These cables have a tendency to deteriorate, will fail over time, and are inaccurate due to lost cable motion. With the Adjustable Position LED indicators, mechanical cables are replaced by more reliable network wiring that allows 'plug n play' connectivity into existing tab or drive position sensors.

If you do not have drive trim or tab sensors, we have the solution. For applications or retrofits that do not have electronic position sensors, Livorsi can provide you with a mechanical to electronic converter solution so that you may take advantage of the accuracy and benefits of Livorsi's LED Indicators.

What sets these displays apart from anything else is the single middle green LED. During calibration, this LED display can be set to indicate 50% of actuator travel, fuel level or whatever you are monitoring. What makes it so special is that it allows you to establish the optimum running angle - or sweet spot (not at 50%), to dial-in the vessel for optimal running efficiency so the novice boater always runs at the correct trim.

ALEDI1RBKBK

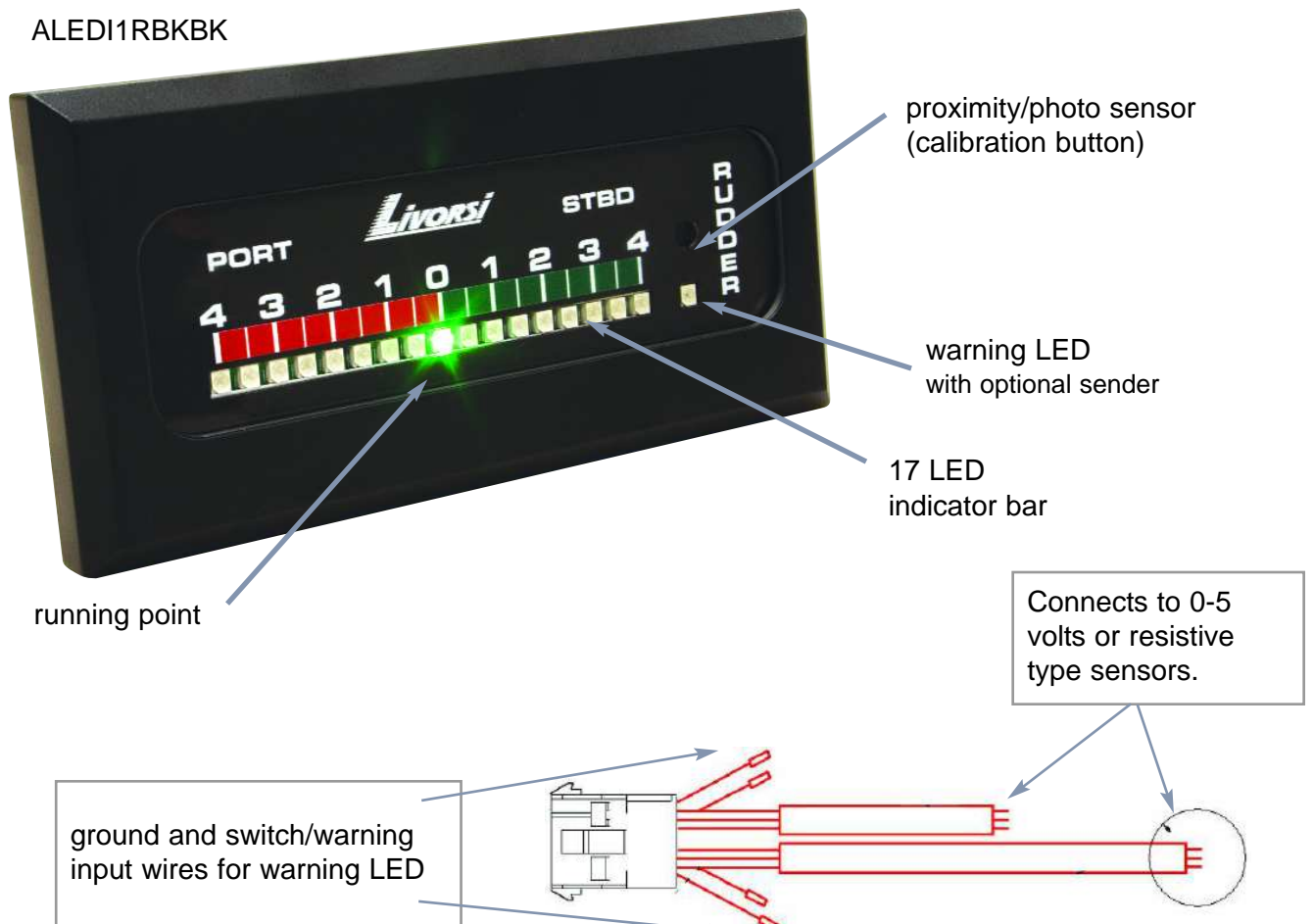

# Adjustable Position LED Indicators

No matter what information you are looking to display (fuel level, drive trim, tab position, etc.), the data is brought into the communication network with plug and play harnessing and is received (Rx) via the network cable to the LED indicator for display.

The LED indicator can also transmit (Tx) this information via CAN bus to other compatible displays such as Garmin, Lowrance or Raymarine via NMEA 2000®, SmartCraft® (with Gateway) or J1939 protocols.

If your boat is already transmitting (Tx) NMEA 2000® data (tabs, drives, fuel level, water level, rudder angle, etc.), simply plug the indicator into the NMEA 2000® backbone to begin displaying the desired feature on the indicator.



completely potted to eliminate exposure to the elements

Receive and Transmit Information between the indicator and screen display

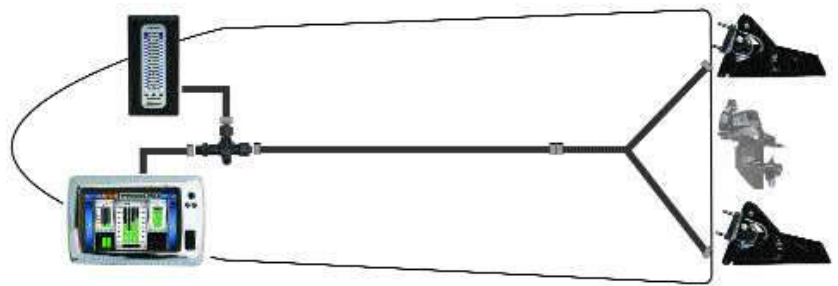

- Simple plug and play installation, eliminates clumsy cables
- No cables means, no loss of motion
- All electronics are environmentally potted
- Built-in photo sensor automatically adjusts to ambient light with 250 brightness intensity levels
- Has the ability to compensate for non-linear tanks giving you accurate readings
- 0-5 volt or resistive type sensors (adjustable)
- 1 to 4 slot configurations, vertical or horizontal

## Dimensions

1 or 2 slot indicator: 2 1/2" W x 4 5/16" H overall  
requires (2) 1-1/8" cutouts for wiring

3 or 4 slot indicator: 3 11/16" W x 4 5/16" H overall  
requires (4) 1-1/8" cutouts for wiring

# Adjustable Position LED Indicators

## Voltage or Resistance Sensors

Tabs, drives, jack plates, fuel level, water level and rudder indicator applications must have a resistance or voltage type sensor present for this system to operate. Below are some of the options.

Mechanical to Electric Converter 0-5 Volts  
(cable not included)

Converts the mechanical signal to an electric signal.  
Bolts on the inside of the transom with a short cable to the unit.

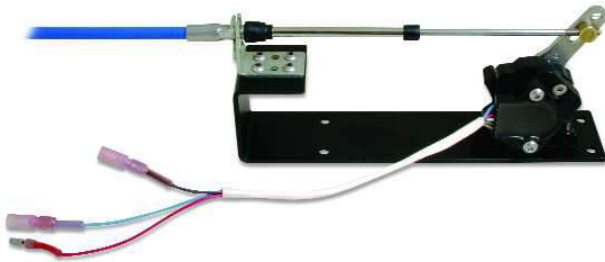

Description	Part Number
converter	CBME5V
Cables for Converter	
3 ft	CA3
4 ft	CA4
5 ft	CA5

Mounted pot on Mercury trim tab 0-5 Volts

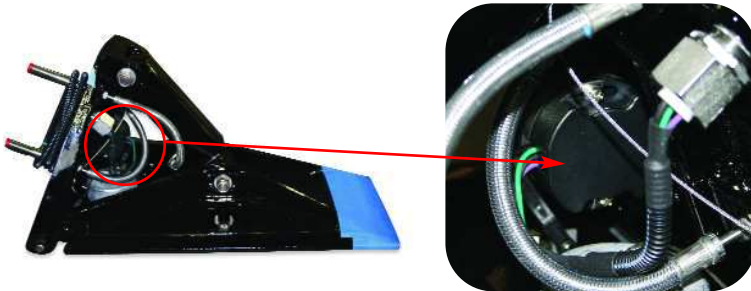

Tabs 2010 or newer should contain the 5 volt sensor  
Tabs 2006-2010 model #'s 280S and 380S should have a bracket to add the sensor

Mercury drive pot 0-5 Volts  
Part Number: 863187A1



Retrofitted tabs-  
Mercury pot 0-5 Volts



Fuel or water level resistive type sensors  
240/33 ohms

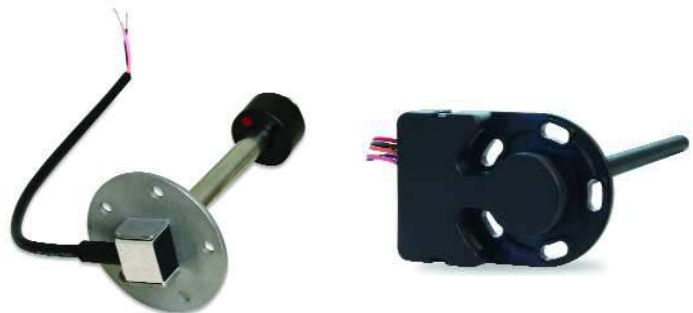

NOTE: Must know at time of placing your order, if sender is a 2 or 3 wire sender

See page 27 and 28 for SmartCraft® Gateways

## Calibration

Calibration is performed via the proximity/photo sensor on the front of the indicator

Inputs may be calibrated using either a 2 or 3 point method:  
minimum / maximum – or minimum / maximum / center running point (green LED)

Has the ability to compensate for non-linear tanks (fuel or water), giving you accurate readings

Each bar is made of 17 LEDs for high precision resolution (indication)  
of the sensor position/level

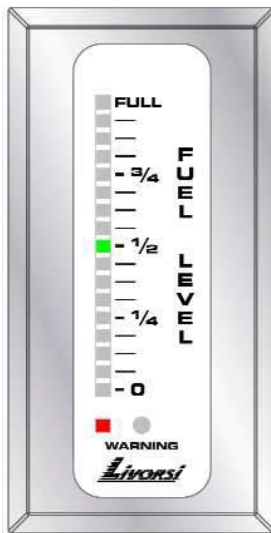

pointer style

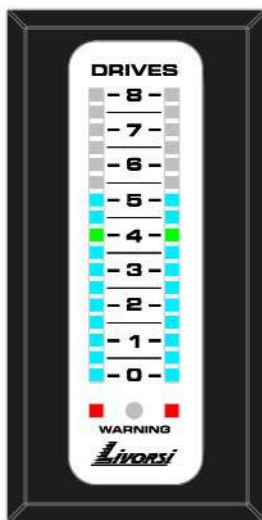

fill bar

## LED Lighting Options Include:

Pointer Style-  
one LED pointer displays your position/level

Fill Bar type-  
multiple LEDs lit in a row, beginning from the top or bottom

The green LED in the center may be calibrated to show optimal level position for Drives, Tabs, etc.

The red LED at the bottom of the indicator can be used as a warning light

Built-in light sensor automatically adjusts to ambient light with 250 brightness intensity levels

## Analog Inputs

Each slot accommodates two analog inputs. One analog input drives the indicator bar, the other drives the optional red warning LED located at the bottom of the slot.

Warnings may include (but are not limited to):  
Oil pressure, water temperature or low fuel with optional switch to close sensor.

## Power Supply

Wide input supply voltage of 7-32 VDC, with reverse polarity protection

# Adjustable Position LED Indicators

## Building Your Indicator Part Number

		FIRST ITEM DATA	SECOND ITEM DATA	CARD COLOR	FRAME COLOR	ORIENTATION
		1 or 2 slot	3 or 4 slot			
Part Number	ALEDI	2D	2T	PL	PL	V
		1 Drive = 1D 2 Drives = 2D  1 Tab = 1T 2 Tabs = 2T  1 Fuel = 1F 2 Fuel = 2F 1 Jack Plate = 1J 2 Jack Plate = 2J 1 Rudder = 1R 2 Rudder = 2R	1 Drive = 1D 2 Drives = 2D 3 Drives = 3D 4 Drives = 4D  1 Tab = 1T 2 Tabs = 2T 3 Tabs = 3T 4 Tabs = 4T  1 Fuel = 1F 2 Fuel = 2F 1 Jack Plate = 1J 2 Jack Plate = 2J	Platinum = PL White = W Black = BK	Platinum = PL White = W Black = BK	Vertical = V Horizontal = H

### Examples of Vertical Layouts

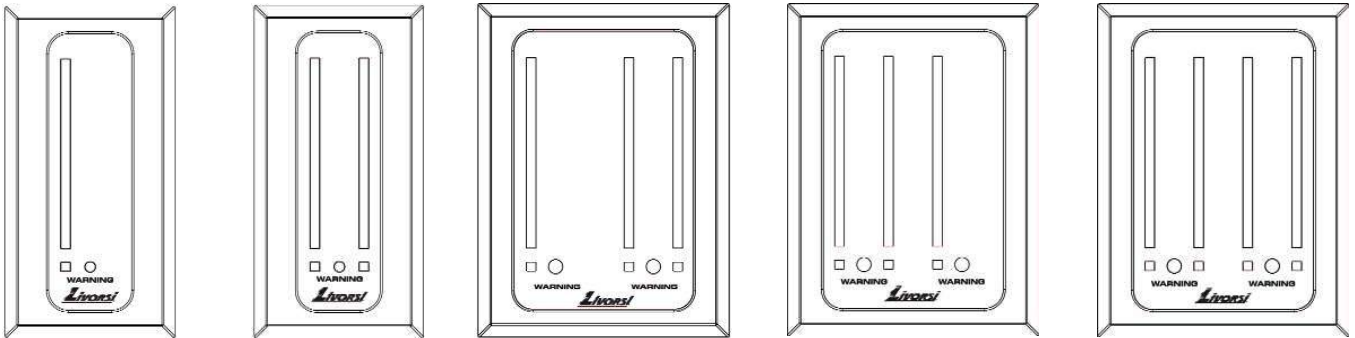

### Examples of Horizontal Layouts

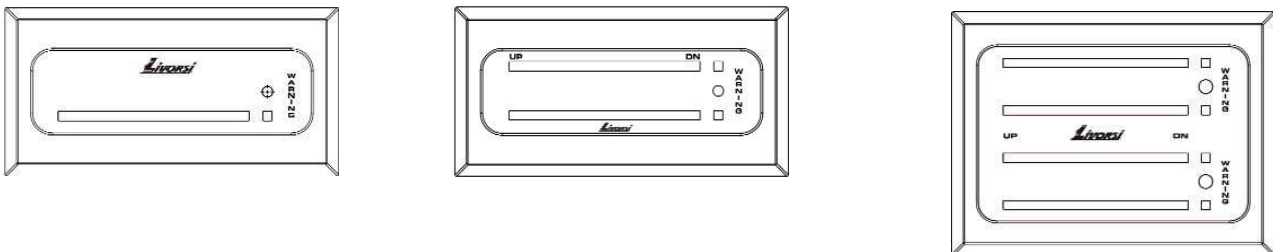

NOTE: A 50% restocking fee will be charged for all returned Adjustable Position LED Indicators.



# Adjustable Position LED Indicators

## Parts To Order

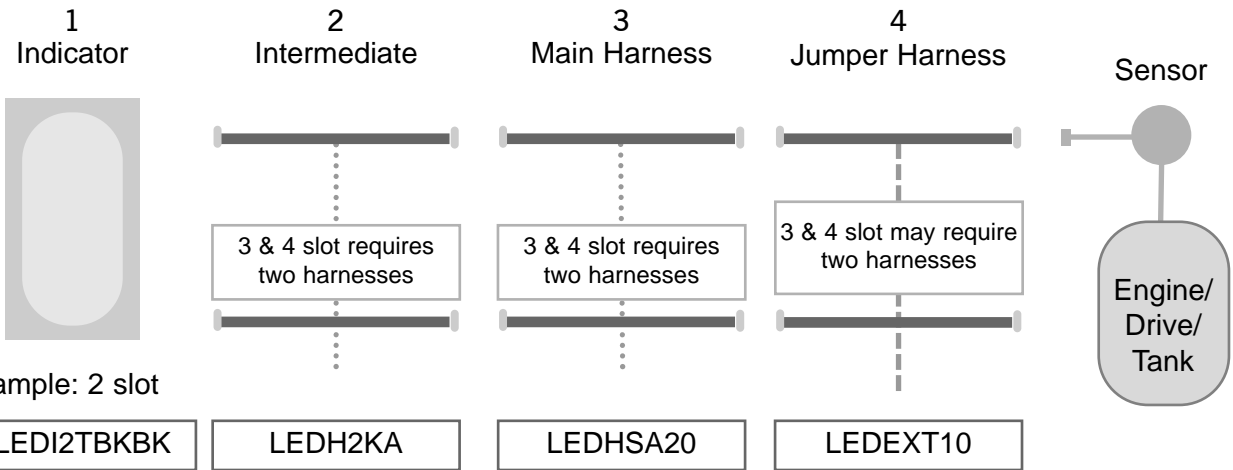









Harness Options		Part Number
2	Intermediate To Main Harness	
	Intermediate to NMEA receive only- 3 feet (must use gateway for SmartCraft®)	LEDHNM30
	Intermediate to Deutsch- Analog In only- No NMEA transmit- 12 inch	LEDHINT
	Intermediate to Deutsch Fully Populated- Analog In-transmit/receive NMEA- 12 inch	LEDH2KA
	Intermediate to Deutsch Dual- Analog In- No NMEA transmit- for 3 or 4 slot- 12 inch	LEDHLINB
3	Main Harness to Jumper Harness	
	Main Harness 20 feet	LEDHSA20
	Main Harness 25 feet	LEDHSA25
	Main Harness 30 feet	LEDHSA30
	Main Harness 40 feet	LEDHSA40
4	Jumper Harness to Sensor Input	
	Tab/Drive/Fuel Jumper Single 5 feet	LEDHEXTS
	Tabs/Drives/Fuel Jumper Dual 10 feet	LEDHEXT10
	Tabs/Drives/Fuel Jumper Dual 15 feet	LEDHEXT15
	Mercury SmartCraft® Drive Jumper Single (Y Cable) 5 feet	LEDHYS
	Mercury SmartCraft® Drive Jumper Dual (Y Cable) 5 feet	LEDHYD5
	Mercury SmartCraft® Drive Jumper Dual (Y Cable) 10 feet	LEDHYD10
	Mercury SmartCraft® Drive Jumper Dual (Y Cable) 15 feet	LEDHYD15
Mechanical to Electric Converter 0-5 Volts	CBME5V	
33 C Series Cables for Mechanical to Electric Converter		
3 feet	CA3	
4 feet	CA4	
5 feet	CA5	
Fuel or Water Level Sensors see page 49		

**NOTE:** Before ordering your Mercury SmartCraft® Drive Jumper harness, first verify which type of drive sensor you have: the 3-wire 0-5 volt sensor or the 2-wire resistive sensor.

# NMEA 2000® Harness

Livorsi can supply you with the necessary cables and connectors to expand your NMEA 2000® network. Below is a chart of in-stock parts, for more options please call Livorsi Marine for pricing and availability.

		
single T connector Part Number: 010-11078-00	120 Ohm female terminator Part Number: 010-11081-00	120 Ohm male terminator Part Number: 010-11080-00
		Mercury Gateway page 27
backbone/drop cable 2 ft Part Number: 000-10068-001	single power cable Part Number: 010-11079-00	
		
backbone/drop cable 6 ft Part Number: 010-11076-00	backbone/drop cable 15 ft Part Number: 000-10070-001	backbone/drop cable 25 ft Part Number: 000-10071-001

# Custom Wire Harness Solutions



Livorsi is ready to meet your short to medium run mechanical and electrical cable assembly requirements.

- Engineering design support to help maximize efficiencies
- Electro-mechanical assembly, process development, fabrication and testing
- Semi-automated wire and cable cutting and stripping for quick change-over
- Ultrasonic wire welding
- Semi-automated terminal crimping
- Custom wire labels to identify individual wires; decreases assembly time and errors
- Soldering

Livorsi utilizes state-of-the-art equipment from top manufacturers like Komax, Stapla, Cami and Shimpo.



Komax BT 722 wire terminal crimper with crimp force technology

## Cutter/Stripper

Cuts and strips wire and cable to precise programmed length.  
individual wires · multi-conductor cable · wire braid · phone wire · full strip · half strip · partial strip

## Wire Terminal Crimper

A semi-automated machine that provides precise and consistent compression of wire terminals, ensuring accurate in-process crimp height, crimp force and strips. Terminal types include: Molex · AMP · Deutsch · Hirose · Others

## Ultrasonic Wire Welder

Helps reduce design time and component costs by integrating 100% quality monitored ultrasonic splice welded wires into your wire and cable harnesses. High electrical integrity with strong metallurgical bonds ensures a reliable connection between various gauges of wire.



## Quality Assurance Testing

In addition to in-process quality assurance, we perform 100% quality control final testing on all wire harness assemblies.

- Cable Eye Testing
- Pull Force Gauge
- LCD Video Microscope
- Value Added Wire Assembly



# The Raw Water Flow System

## Safe guard your cooling system from costly damage with Livorsi's Raw Water Flow System

The Raw Water Flow system indicates your engine's water flow volume. This system warns you of a potential problem or danger that would otherwise not be indicated by a water pressure gauge alone, preventing cosmetic and structural damage to expensive exhaust headers, intercoolers and other cooling systems.



### What is Water Flow?

Water flow is a real indication of water surging through a cooling system such as: exhaust headers, sea strainers, impellers, Gen sets, intercoolers and any other marine or industrial applications that utilize water flow.

### Why You Need It.

Many people confuse water flow with water pressure; many OEM engine manufacturers measure water pressure in different areas of the motor. Water pressure may not be telling you the real story of water flow.

The danger may be lurking in the water flow which could be caused by: A plugged heat exchanger, extensive debris build-up in the intercooler or sea strainer, a kinked hose, worn impeller, water pickups not collecting enough water for cooling system.

Low water flow results in; cosmetic and structural damage to expensive exhaust headers caused by burned impellers or the clogging and damage of intercoolers or strainers.

### How It Works

Calibration of the system is set at idle and at wide open throttle (WOT). This will generate the cooling system's normal operating range. When water flow rises or drops more than 20% from that range (regardless of RPM), it will trip the alarm illuminating the built-in LED light; an optional audible alarm may be added. The LED light shines with intensity, making it visible in direct sunlight.

### Easy to Install

Pick the size of the hose and mount the Tee in-line on the output side of a sea strainer or sea pump. The paddle wheel sensor installs in the Tee and can be easily removed for inspection.



The Raw Water Flow system consists of:

- 2 5/8" panel mounted gauge with internal warning light
- Bronze Tee
- PCB board
- Harness
- Paddle wheel transducer

Color Codes	
Dial	<div style="display: flex; align-items: center; gap: 10px;"> <div style="border: 1px solid black; border-radius: 50%; width: 20px; height: 20px; background-color: #cccccc;"></div> PL           <div style="border: 1px solid black; border-radius: 50%; width: 20px; height: 20px; background-color: #000000;"></div> BK         </div>
Rim	<div style="display: flex; align-items: center; gap: 10px;"> <div style="background-color: #000000; color: white; padding: 2px 5px; font-weight: bold;">BKR</div> <div style="background-color: #cccccc; padding: 2px 5px; font-weight: bold;">PLR</div> <div style="background-color: #cccccc; padding: 2px 5px; font-weight: bold;">PSR</div> </div>

Water Flow Kits 2 5/8" cutout, 2 3/4" overall		
Tee Fitting Size	Base Part Number	
1 inch I.D. hose	WFG + dial color + rim color + rim style +	1
1.25 inch I.D. hose	Race Rim- R	1.25
1.5 inch I.D. hose	Mega Rim- M	1.50

# FLS Senders

For fuel, diesel and water

## Simple Cut & Calibration Method

- For use with fuel, diesel and water - not intended for holding tanks (Gray Water)
- Works by sensing pressure so additives to fuel (Ethanol) will not affect accuracy
- Simple cut & calibration procedure
- Senders use microcontroller driven sensor technology for a high degree of accuracy +/- 2 %
- Designed to be a replacement for the standard fuel sender with a standard SAE bolt hole pattern
- Adjustable SAE J1810 5 bolt pattern makes installation much easier, allows for a 15° of rotation adjustment
- Cap is constructed of a fuel compatible, durable nylon
- No moving parts to break or wear out for years of trouble free service
- Standard is 240-33 ohms, other ranges available upon request, please specify
- 0-5 volt or 4-20 milliamps available upon request.
- Dampened to provide smooth operation of pointer
- 12 volt standard or 24 volt systems, please specify

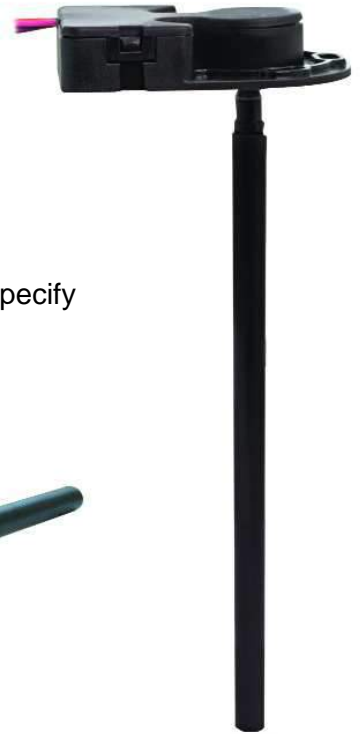

bolt pattern

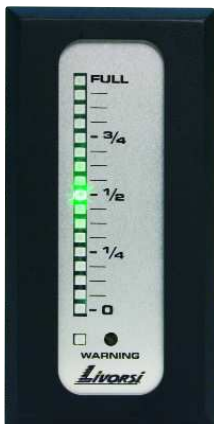
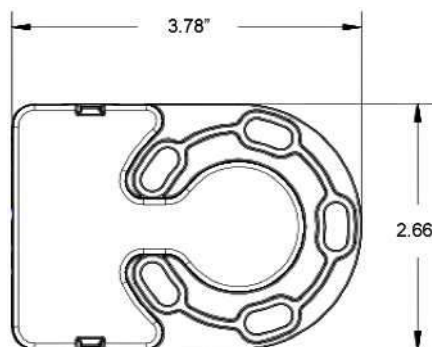

Match these senders with our Adjustable Position LED Indicators, page 36

Ask us about Holding Tank (gray water) senders.

240-33 OHMS 12 Volt Senders	Part Number
12 inch,	FLS12
24 inch	FLS24
36 inch	FLS36
48 inch	FLS48
Cut & Calibrate	CC FL
Other resistance ranges available upon request.	

## Autocal Fuel Level Senders

### How It Works

AutoCal Fuel Level senders work by measuring capacitance. Electronics in the head convert the measured capacitance between the inner-sensing tube and the grounded outer tube to the programmed output of ohms or volts.

- No moving parts to wear out or break
- Fuel level reading unaffected motion
- Installs in the standard SAE 5 bolt pattern
- 2 terminal sender works on both 12 or 24 volts
- 240-33 ohms in stock, other ohm resistances available upon request
- Not recommended for mixed fuels

When ordering, specify:(1)- depth of tank, (2)- gas, diesel or gasohol

240-33 ohms Sender Length	Part Number
0-12 inch	AFLS12
13-24 inch	AFLS24
25-36 inch	AFLS36
37-48 inch	AFLS48

240-33 ohms Sender Length	Part Number
49-60 inch	AFLS60
61-72 inch	AFLS72
Cut & Calibrate	CC FL



## Fuel, Diesel and Water Level Senders

An electronic sender suitable for fuel, diesel and water.

- Constructed to meet/exceed all applicable ISO, NMMA, ABYC and USCG standards
- Standard SAE 5 hole pattern
- Constructed of 316 stainless steel
- Fully insulated to protect against voltage inside the tank
- The float is the only moving part of the sensor minimizing mechanical failure

### How It Works

Measurement is achieved by a series of reed switches positioned inside the level tube. The float with built in magnets then triggers the reed relays generating a potential - free resistance with an ohm value that increases or decreases.

240-33 ohms Sender Length	Part Number
4 inch	SFW4
5 inch	SFW5
5.5 inch	SFW5.5
6 inch	SFW6
7 inch	SFW7
8 inch	SFW8
9 inch	SFW9
10 inch	SFW10
11 inch	SFW11
12 inch	SFW12
13 inch	SFW13

240-33 ohms Sender Length	Part Number
14 inch	SFW14
16 inch	SFW16
18 inch	SFW18
20 inch	SFW20
22 inch	SFW22
24 inch	SFW24
26 inch	SFW26
28 inch	SFW28
30 inch	SFW30
32 inch	SFW32
34 inch	SFW34
36 inch	SFW36



Other resistance outputs, lengths or senders with a 1 ¼" or 1 ½" NPT are available upon request.

## Ultra Thin

Livorsi indicators feature a no-slack spring load assist, eliminating slack in the cable giving you a faster indication of your drives and tabs.

High intensity LED pointers are bright enough to see in direct sunlight with low power consumption.

- Dash mounted indicator
- Your choice of LED pointers or fluorescent red pointers
- Aluminum and composite construction
- Adaptable to any actuator with 3 1/4" throw

Ultra Thin face dimensions	
3 or 4 slot	3 3/4" W x 5" H

Indicators w/ LED Pointers			
UMILED	+ number of slots +	S	card & frame color
Specify: direction of cable entry, horizontal or vertical layout, number of drives, tabs, etc.			

Indicators w/ Fluorescent Pointers			
		Part Numbers	
# of drives	# of tabs	black	platinum
1 drive	2 tabs	UMI1D2TBKBK	UMI1D2TPLPL
2 drives	2 tabs	UMI2D2TBKBK	UMI2D2TPLPL
Specify: direction of cable entry, horizontal or vertical layout			

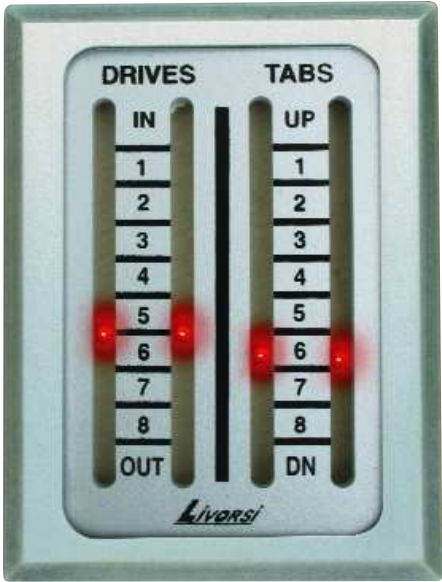

UMILED4SPLPL  
vertical layout  
LED pointers



UMI2D2TBKBK  
horizontal layout  
standard pointers

# Mechanical Indicators

## Standard Size

- Dash mount indicator
- Your choice of LED pointers or fluorescent red pointers
- Aluminum and composite construction
- Adaptable to any actuator with 3 1/4" throw

Standard size face dimensions	
1 or 2 slot	2 1/2" W x 5" H
3, 4 or 5 slot	5" W x 5" H

Indicators w/ LED pointers			
MILED	+ number of slots +	S	+ card & frame color
Specify: direction of cable entry, horizontal or vertical layout number of drives, tabs, etc.			

Indicators w/ Fluorescent Pointers			
# of drives	# of tabs	Part Number	
		black	platinum
0 drives	2 tabs	MI2TBKBK	MI2TPLPL
1 drives	0 tabs	MI1DBKBK	MI1DPLPL
1 drives	2 tabs	MI1D2TBKBK	MI1D2TPLPL
2 drives	0 tabs	MI2DBKBK	MI2DPLPL
2 drives	2 tabs	MI2D2TBKBK	MI2D2TPLPL
3 drives	0 tabs	MI3DBKBK	MI3DPLPL
3 drives	2 tabs	MI3D2TBKBK	MI3D2TPLPL
Specify: direction of cable entry, horizontal or vertical layout			

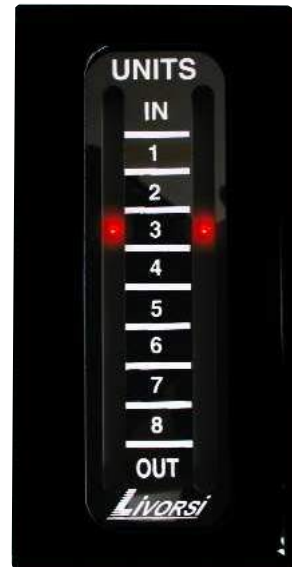

MILED2SBKBK  
vertical layout  
led pointers

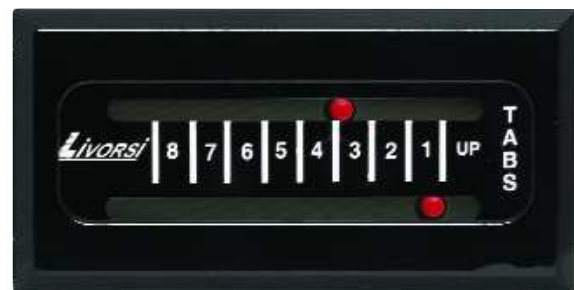

MI2TBKBK  
horizontal layout  
standard pointers

## 33C Series Cables

- Sold in two foot increments
- Sizes range from 10 ft. to 38 ft.
- Stainless steel core
- Chrome plated brass
- 3 1/4" throw
- Thread size 10x32



Description	Part #
33C Series Cable	CA + length



# Trim Panels

- Military spec rocker switches
- Sealed and waterproof
- No exposed screws
- Powder coated aluminum

When ordering specify

- Panel color
- Switch cover colors: red, white or translucent



Panel dimensions

3 3/4" W x 3 3/4" H



T = Tabs  
D = Drives  
O = Override



Wired Panels	
Description	Part Number
1 drive 2 tabs	TP1D2T
2 drives	TP2D
2 drives/override	TP2DO
3 drives	TP3D
2 tabs	TP2T
2 tabs/override	TP2TO

Unwired Panels	
Description	Part Number
1 drive 2 tabs	UTP1D2T
2 drives	UTP2D
2 drives/override	UTP2DO
3 drives	UTP3D
2 tabs	UTP2T
2 tabs/override	UTP2TO

## Cable Thru Hull Fittings

Used with mechanical indicators to connect 33C cables to actuators.



Cable Thru Hull Fittings for 33 C Series Cables	
Description	Part Number
stainless steel 90°	THF
stainless steel 45°	THA
solid billet stainless steel 90°	THFB
solid billet stainless steel 45°	THAB
quick disconnect stainless steel 10x32 thread, OD 3/8"	QDBJ

# Steering Wheels

## All Wheels

- 13 1/2" diameter
- 6 bolt pattern
- 10-32 thread pitch
- Black hub
- Center cap
- Mounting screws



Isotta Carbon Fiber

Part Number ISWK13CFBK



Momo- Spargi

platinum MSSWPPL



Momo- Ponza

platinum MPSSWPPL



Momo- Linosa

Part Number MLSW



Stainless Steel  
Fishing Wheel w/Knob  
hub is not used with this wheel

Part Number GWSSFK



Stainless Wheel w Knob

Part Number GWSSK



Momo- Budelli

Part Number MBSWP

Billet Aluminum Hub Adapter



Wheel Hub Adapter

- 3 inches deep
- 6 bolt pattern

Includes:

- Hub
- Center cap
- Mounting screws

Description	Part Number
black	HABK
platinum	HAPL

Anodized Optima Battery Box



- Withstands the weight of 250 lbs person
- Machined from billet aluminum
- Black anodized finish is non-corrosive
- Box cover has a slip resistant surface
- Can be stringer mounted
- Measures: 11 15/16" L x 8" W x 6 5/8" H

Description	Part Number
box and cover	BBBO34A

# Accessories

## Fire Extinguishers & Mounts

### FE Bar Mount

- Machined of billet aluminum
- Fits 1 1/2", 1 3/4" and 2" tubing
- Black powder coat finish
- Quick release pin



### FE Flat Mount

- Machined of billet aluminum
- Black powder coat finish
- Quick release pin



### Fire Extinguisher

- Encased in marine approved chrome
- Dry ABC extinguisher
- 2 1/2 lbs, refillable
- Extinguisher and mounts are sold separately

Description	Part Number
fire extinguisher	FE
bar mount	FEBMKBK
flat mount	FEMBK

## Grab Handles



Stainless Steel Grab Handle	
10 1/2" center to center 11 3/4" overall	GHSSS11BK
15 1/4" center to center 16 1/2" overall	GHSSS16BK

## Switches

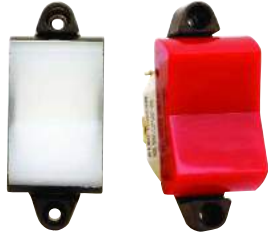

### Military Rocker Switches

- Military type specs
- Environmentally sealed
- 15 amps at 28 VDC
- .94" X 1.51" cutout

Single Pole	
mom on/off/mom on	MRSSMFM + color
Double Pole	
mom on/off/mom on	MRSDMFM + color
Military Cover	MC + color
covers available: red, white or translucent	



### Military Toggle Switches

- Military type specs
- Environmentally sealed
- 15 amps at 28 VDC
- 1/2" cutout with screw terminals
- Lift / lock lever

Single Pole	
on/off	MTSSNF
on/off/on	MTSSNFN
mom on/off	MTSSMF
Double Pole	
on/off	MTSDNF

## Electric Hatch Actuator



- Safe working load limit of 400 lbs.
- Heavy duty motor allows for locking of hatches
- Marine grade stainless steel housing
- Lifts 2X as fast and has 2X the power of other electric actuators
- A more cost-effective alternative to hydraulic and pneumatic models
- 12 VDC

Description	Closed	Open	Part Number
4" throw	10.32"	14.32"	SSA4
8" throw	14.32"	22.32"	SSA8
12" throw	18.32"	30.32"	SSA12
16" throw	22.32"	38.32"	SSA16
18" throw	24.32"	42.32"	SSA18
24" throw	30.32"	54.32"	SSA24

### Mounting Hardware

bracket only washers & bolts not included	HAB
adjustable bracket only washers & bolts not included	HABT
quick release pin	HAQRP
mounting kit includes bracket, sleeve washer & bolts	HAMK



HAQRP  
stainless steel/aluminum



HAB  
stainless steel



HABT  
aluminum

# Low Lux Night Vision Camera

The Low Lux Night Vision camera is a safety device that extends your work hours on the water. The black and white picture allows for safe maneuvering of waterways or when docking. Use as a stand alone device or an enhancement to radar. The 25 mm low lux camera connects to any monitor with a RCA video jack, or add a DVR to record your trip.



The camera can be mounted permanently or use the optional vacuum mount for quick and easy removal. Measuring only 6" in length and 3.5" in diameter the camera is small enough to be stored after usage to prevent theft. This camera is a valuable tool in extending your time on the water, yet is priced far below thermal imaging systems.

Works with all types of vessels -  
From ships, work boats, yachts, commercial boats to small run a-bouts and fishing boats.

The camera is sealed to IP66 rating and meets Coast Guard electrical standards. This assures that the camera will always deliver a reliable and high quality video image. Splash proof and damage resistant. Very durable and water tight for on deck mounting locations.

Match this camera with a DVR recorder for up to one week of continuous trouble free recording at a low cost.

Specifications	
Camera Type	Low Lux
Input Power	12V DC + or hardwire to a switch to power the camera
Current	Less 1 amp
Diameter and Length	3.5" diam. x 6" (camera housing)
Resolution	570TVL
LUX	0.0003 Lux
Picture Element	437K pixels
Rating	IP66
Lens Focal Length	25mm std.
Angle of View	19.9 degrees
Camera Warranty	3 years
Video Outputs	Composite RCA video jack, BNC composite video with standard 20 foot cable provided, RG 59 low loss coax cabling



With a small amount of ambient light the low lux camera will give the operator a detailed picture unlike thermal.

Description	Part Number
low lux camera	CNVLLW
vacuum mount	CVMR



With over two decades of experience in the industry, Custom Marine, Inc. is committed to producing premium marine exhaust systems.

**CMI is your #1 source for stainless exhaust!**

CMI relies on a technological expertise in designing and manufacturing high-quality mufflers, exhaust systems and components to withstand some of the harshest environments on earth - offshore race boats and military assault crafts.

**Examples of CMI Products:**

- Water jacketed exhaust elbows
- Off road/sand car headers
- Automotive exhaust
- Blanketed elbows
- Custom applications available
- Compatible with all engine manufacturers
- In house design and CAD capabilities
- Various alloy options also available
- Many finish options
- Exhaust tips
- Risers



off-road and automotive applications



**Water Pick Ups**



39205



39200

- Made from high grade 304L domestic stainless steel
- Extremely low drag design
- Fully adjustable to fine tune block pressure
- Large 1 1/4" ID fittings for high demand water systems

Description	Part Number
Rotary Adjustment pick-up	39205
Vertical Adjustment pick-up to be used for higher transom locations	39200

# Transom Tips

CMI offers both baffled and non-baffled stainless steel transom tips to fit most marine engine installations. CMI's baffled transom tips are available in either straight cut or down-turned configurations and include a replaceable internal flapper which acts as a noise reducer and qualifies as a baffle as required by certain ordinances.

### Flapper Style Tips:

Both external and internal flapper versions available.

### Baffle Style Tips:

Available in single baffle design or multiple baffle to reduce exhaust noise and protect against water ingestion.

### Turbo Tips:

Designed to reduce sound levels and produce a mellow exhaust note verses a harsh tone.

### Down Turned Tips:

Available with the transom tip incorporated or as a clamp on style. Achieve quieter dB with the external version of an underwater system.

Flapper Style



Turbo Tip



Down Turn

Angle End

Straight End



Description	Part Number
Baffled Tip, Straight-Cut	39105
Baffled Tip, Down-Turned	39135
Polished Stainless Steel Exhaust Tip w/ single plane baffle	39295
Rebuild Kit for 39295 Includes single plane baffle and rubber flap	41320
4 inch Ø Polished Stainless Steel Exhaust Tip Angle end	39221
4 inch Ø Polished Stainless Steel Exhaust Tip Straight end	39213



# SS Sea Strainer



- Stainless steel construction
- Two bungs measure 1", one bung measures 1/2"
- 60 GPM flow at 22 PSI
- High impact 1" acrylic lid
- Removable stainless steel basket with easy lift handle
- Optional floor mount brackets & fittings available

Description	Part Number
same side bungs	SS5SS
straight through bungs	SS5ST

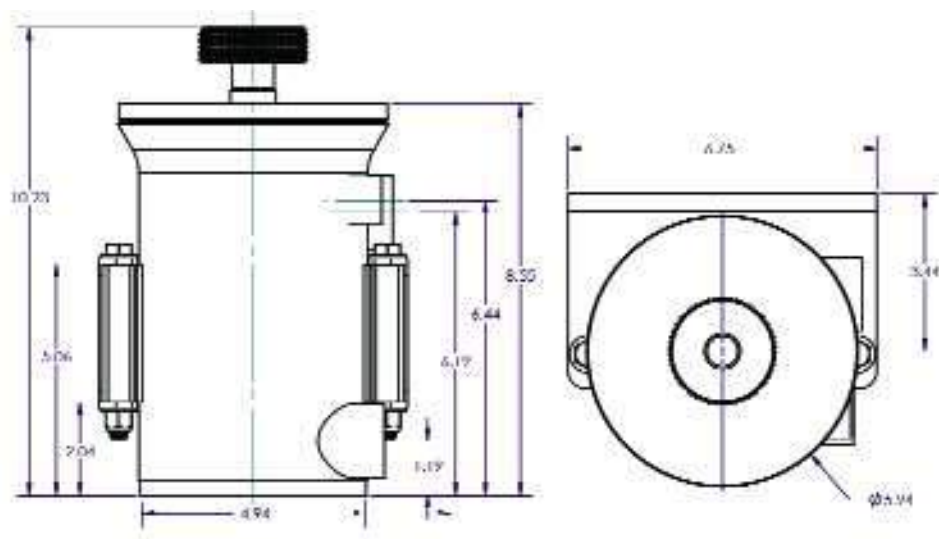

## SS Sea Strainer Fittings



SSPRV



GSSFS



GSSF90



GSSF45



SSFMB

Description	Part Number
1/2" NPT adjustable blow off valve	SSPRV
1" NPT to 1 1/4" slip on	GSSFS
1" NPT to 1 1/4" slip on 90 degree fitting	GSSF90
1" NPT to 1 1/4" slip on 45 degree fitting	GSSF45
floor mount brackets- pair	SSFMB

# HP Sea Strainer

- Available in a 5", 6" or 8" diameter can, any height needed
- Easy to clean and maintain and very serviceable
- Can be plumbed from 3/4" pipe to 2" pipe
- High quality polished finish
- Universal bracket for either side of your stringer
- 100 PSI maximum
- Inlet and outlet fittings are 1 1/4" NPT
- Flush/pressure relief fitting is 1/2" NPT

Part Number 39146



## High Flow Fittings

- For use with HP Sea Strainer
- Made never to starve your engine of water
- Available in all sizes from 3/4" pipe to 2" pipe
- Available in straight to 180 degrees, in 30 degree increments
- High quality mandrel bends
- Bright polished finish to give your engine compartment the "bling" you want



3/4" NPT to 1" Hose, Straight Part Number 19650	1 1/4" NPT to 1 3/8" Hose Barb, 45° Part Number TBD	1 1/4" NPT to 1 3/8" Hose Barb, 45° Part Number TBD
3/4" NPT to 1" Hose, 90° Part Number 19580	1 1/4" NPT to 1 3/8" Hose Barb, 60° Part Number TBD	1 1/4" NPT to 1 3/8" Hose Barb, 60° Part Number TBD
1" NPT to 3/4" NPT Adapter Part Number 19600	1 1/4" NPT to 1 3/8" Hose Barb, 90° Part Number TBD	1 1/4" NPT to 1 3/8" Hose Barb, 90° Part Number TBD
3/4" NPT Plug Part Number 19140	1 1/4" NPT to 1 3/8" Hose Barb, 130° Part Number TBD	1 1/4" NPT to 1 3/8" Hose Barb, 130° Part Number TBD
1" NPT Plug Part Number 19155	1 1/4" NPT to 1 3/8" Hose Barb, 150° Part Number TBD	1 1/4" NPT to 1 3/8" Hose Barb, 150° Part Number TBD
1" Hose to 3/4" Hose Barb, 90° Part Number 19100	1 1/4" NPT to 1 3/8" Hose Barb, 180° Part Number TBD	1 1/4" NPT to 1 3/8" Hose Barb, 180° Part Number TBD
1" Hose to 1" Hose Barb, 90° Part Number 19330	1" Hose to 1" Hose Barb, 90° Part Number 19330	
1 1/4" NPT to 1 3/8" Hose Barb, Straight Part Number TBD	1 1/4" NPT to 1 3/8" Hose Barb, Straight Part Number TBD	
1 1/4" NPT to 1 3/8" Hose Barb, 30° Part Number TBD	1 1/4" NPT to 1 3/8" Hose Barb, 30° Part Number TBD	

### WARRANTY

All Livorsi Marine® products carry a limited one year warranty for repair or replacement at Livorsi's discretion. All Livorsi Marine® products are warranted to be free of defects in material and workmanship. Users/Customers of Livorsi Marine®/Livorsi® products agree not to hold Livorsi Marine, Inc., its owner or employees responsible for any damages occurring by improper installation or use of Livorsi Marine® or Livorsi® products. The company, owner or its employees will not be liable for more than the cost of the original product and in no event will Livorsi Marine® or Livorsi® be liable for special, indirect or consequential damages of any kind whatsoever.



Moose Boats

Metal Shark



Brunswick Commercial



# LIVORSI®

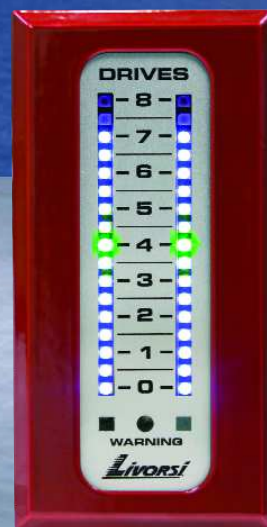

# Table of Contents

---

Actuators - please visit website	
Battery Boxes - Optima	103
Beverage Holders	105
Cable Thru Hull Fittings	82
Cleats	90
Color Options	22
Controls	
DTS Controls	10
QR Series DTS Control	12
Electronic Side Mount	14
Platinum Series	6
Side Mount Control - Mechanical	17
Hardware and Accessories	18
Dash Designer	4
Dash Panels	4
Data Gateways	60
Drive Showers	101
Dock Lines/Fender Lines	91
Fire Extinguisher and Mounts	104
Foot Pedal- Electronic	15
Gauge Accessories	
Bezels	56
Visor rims	55
Gauge Hardware	38
Gauge Styles	21

Gauges	
Depth Finder	41
GPS Speedometer with Odometer	40
Industrial	23
Mega and Race	29
Vantage View®	42
GPS Antennas/Receivers	39
Grab Handles	104
Hatch Actuators	79
Indicators	
LED Position Indicator	73
Mechanical Indicators	81
Led Lighting	
Navigation Lights	97
Underwater LED Lighting	96
Mufflers - Sound Elimination	99
NMEA® 2000 Harnessing	59
Senders - Fuel or Water Level	58
Sea Strainers	102
Steering Wheel Hub Adapter	90
Steering Wheels	83
Switches	92
Wire Harness Solutions	16

# Dash Panels

Our panels are available in real carbon fiber.

Send us a dimensional drawing, or your old panel and we'll recreate it.



blue



red

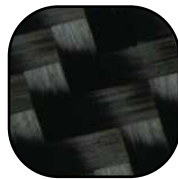

carbon  
Fiber



silver  
carbon  
fiber

# DashDesigner

This interactive tool lets you select some of our custom options. Or, check out our Custom Gauge Gallery to see some of our customer's creations.

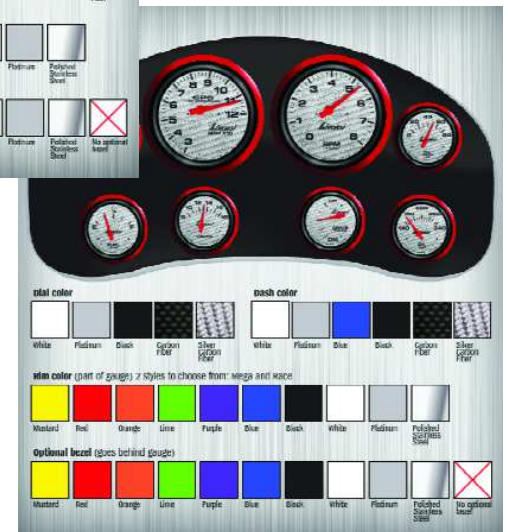
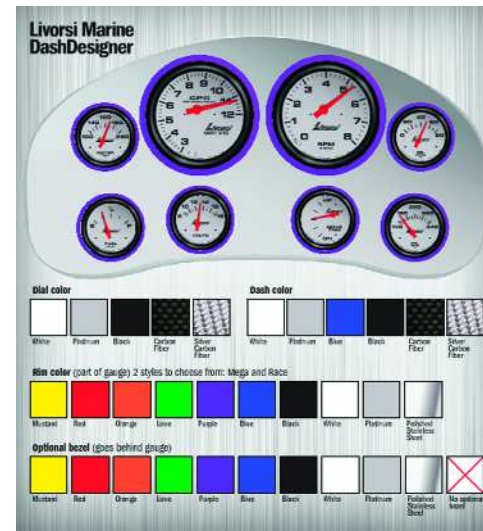

# Custom Gauges

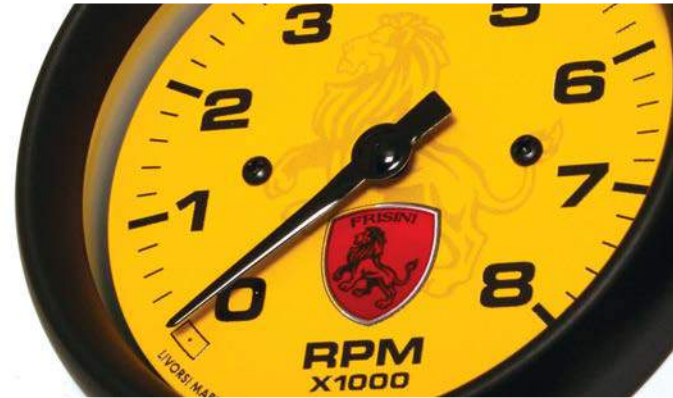



# Platinum Series Controls

---

Designed to be ergonomically comfortable to the operator while being lighter and more compact for fitting into tight spaces. The Platinum Series is finished with a two coat process which prevents corrosion and can be configured for single or multiple engine's for Drives, Transmissions, Jet Drives or Buckets.

## Available in three throttle/shift configurations:

- **Fully Mechanical**
- **Fully Electric**
- **Mechanical/Electric (Hybrid)**

Configurations include one or any combination of the below:

- The use of mechanical 33C or 43C cables for mechanical levers
- Electric configurations use compact direct driven angular sensors, 0-5 Volt electronic sensors or a PWM signal
- The use of a micro switch - for electronic transmission shifting
- Single, twin and triple in-handle trim switch available
- Check with the engine manufacturer or Livorsi Marine for electric control compatibility

Arched



Billet



Standard



## Fully Mechanical Billet Throttle Control with Contour base in Carbon Fiber



Check with the engine manufacturer or Livorsi Marine for electric control compatibility.

# Platinum Series Controls

## Dimensions

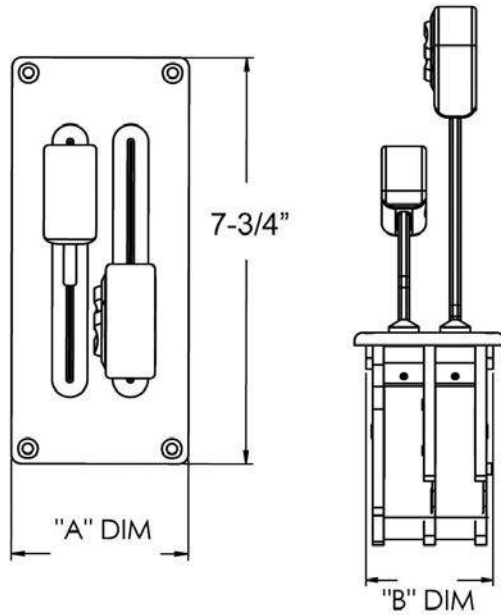

Handles	Overall Size	Cutout Size
	A DIM	B DIM
1	2-1/4" x 7-3/4"	1-7/8" x 6-1/2"
2	3-11/32" x 7-3/4"	2-7/8" x 6-1/2"
3	4-7/16" x 7-3/4"	3-7/8" x 6-1/2"
4	5-17/32" x 7-3/4"	4-7/8" x 6-1/2"
5	6-15/32" x 7-3/4"	5-7/8" x 6-1/2"
6	7-9/16" x 7-3/4"	6-7/8" x 6-1/2"
8	9-9/16" x 7-3/4"	8-7/8" x 6-1/2"
Depth	Mechanical / Hybrid	Electric
	8.125"	6.5"

For a list of part numbers please refer to our price list available online.

# Platinum Series Controls

## Build Your Part Number

Billet Style / electric throttle / mechanical shift / four handle / single switch / contour base / black knobs

<b>B</b>	<b>B</b>	<b>E</b>	<b>M</b>	<b>2</b>	<b>2</b>		<b>S</b>	optional		<b>C</b>	<b>B</b>	<b>B</b>	<b>K</b>
Throttle style		Throttle Actuation	Shift Actuation	# of Throttle handles	# of Shift handles	Switches		for a contour base		Knob color			
<b>Code:</b>			<b>Code:</b>	<b>Code:</b>	<b>Code:</b>	<b>Code:</b>		<b>Code:</b>		<b>Code:</b>			
Arched	AR	full mechanical	MM	0	0	no switch		contour chrome	CB	black	BK		
Billet	BB	full electric	EE	1	1	single	S	NOTE: above in Carbon Fiber					
Standard	ST	mech throt/elec shift	ME	2	2	dual	D			blue	BL		
		elec throt /mech shift	EM	3	3	triple	T			black star	BS		
				4	4	push button	PB			chrome	CH		
										gun metal	GU		
										lime	L		
										mustard	MU		
										orange	O		
										platinum	PL		
										purple	PU		
										red	R		
										white	W		

push buttons only available on Arched style controls

### Specify the following:

#### 1. Comments:

Configuration

ex: S-S-T-T

Right or Left Thumb Actuation

### Carbon Fiber Base Options

black carbon fiber



silver carbon fiber



### Powder Coat Options



BBEM22SCBBK

# Livorsi SmartCraft® DTS

Digital Throttle & Shift



These DTS controls are smaller and lighter: constructed of stainless steel and billet aluminum for years of dependable service. The user has the ability to adjust tension for each handle. The ergonomically designed knobs feature your choice of single or twin drive trim switches or momentary up and down switches.

- A license from Mercury allows Livorsi to combine DTS technology with the options and quality of Livorsi controls
- Designed for direct drive of the triple redundancy position pots
- Eliminates the need for mechanical cables
- Engineered for smooth shifting and throttling
- Single, twin, triple, and quad control configurations are available in a variety of styles and colors.

### Compatible with:

- Mercury DTS equipped engines
- Verado 150 - 400 SCI
- Mercruiser 5.0L - 8.2L
- Optimax 225
- Mercury Racing 520, 565, 1100, 1350, 1650
- and Cummins engines that are DTS capable

Dimensions				
Number of Handles	Overall		Cutout	
	A DIM		B DIM	
2 handle	3 3/8 in.	7 3/4 in.	2 7/8 in.	5 1/8 in.
3 handle	4 1/2 in.	7 3/4 in.	4 1/64 in.	5 1/8 in.
4 handle	5 11/16 in.	7 3/4 in.	5 3/16 in.	5 1/8 in.
6 handle	8 in.	7 3/4 in.	7 1/2 in.	5 1/8 in.
8 handle	10 5/16 in.	7 3/4 in.	9 13/16 in.	5 1/8 in.

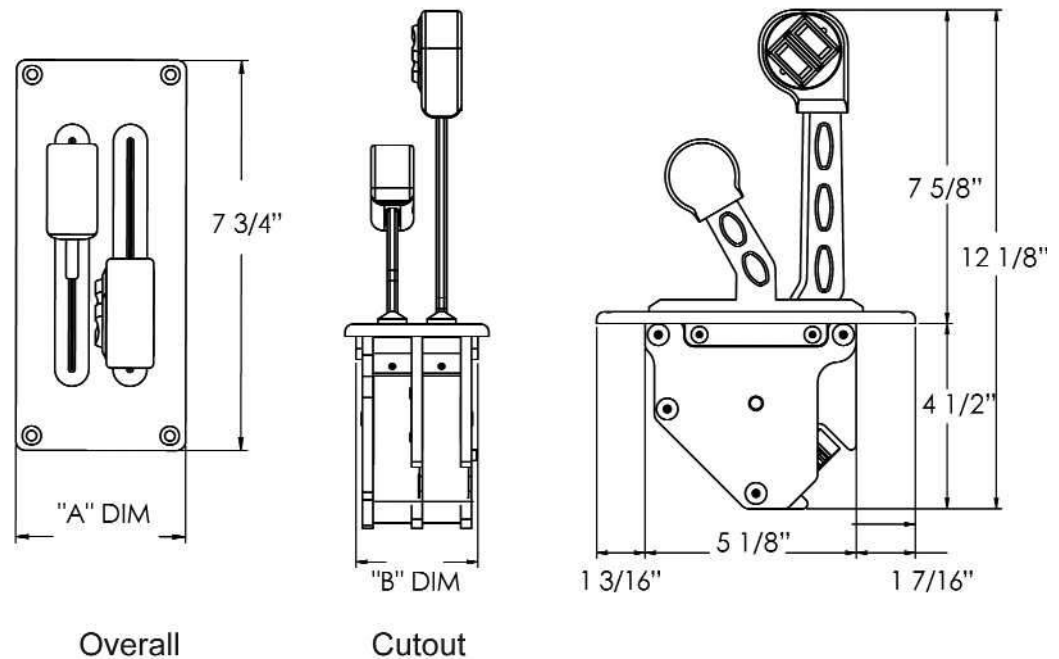

Shadow Mode Available

### Shadow Mode

Shadow mode available for automatic throttle synchronization for triple or quad engine applications; where two throttle levers operate three engines or four engines. Requires appropriate Mercury shadow mode rigging kit.

Chrome Base			
Number of Handles	No Switch	Single Switch	Dual Switch
2 handle	DTSBB11 + color	DTSBB11S + color	DTSBB11D + color
4 handle	DTSBB22 + color	DTSBB22S + color	DTSBB22D + color
6 handle	DTSBB33 + color	DTSBB33S + color	DTSBB33D + color
8 handle	DTSBB44 + color	DTSBB44S + color	DTSBB44D + color
Powder Coat Base			
Number of Handles	No Switch	Single Switch	Dual Switch
2 handle	DTSBB11PC + color	DTSBB11SPC + color	DTSBB11DPC + color
4 handle	DTSBB22PC + color	DTSBB22SPC + color	DTSBB22DPC + color
6 handle	DTSBB33PC + color	DTSBB33SPC + color	DTSBB33DPC + color
8 handle	DTSBB44PC + color	DTSBB44SPC + color	DTSBB44DPC + color
Mercury DTS Rigging Kits			
Single Engine	Twin Engine	Triple Engine	Quad Engine
84-892955K04	84-893378K04	892955K32	Order (4) Single Engine
Mercury Shadow Mode Rigging Kits			
Triple Engine	Quad Engine		
8M8025983	8M8025984		



split throttle/shift configurations available

### Optional Contour Base

For a contour base add the following code after the control part number:

Description	Part Number
chrome contour base	CB
powder coat contour base	CBPC

#### Colors:



# QR Series™ DTS Billet Controls

Introducing **Livorsi Marine's New QR Series™** throttles (Quick Response) designed specifically for all Mercury compatible DTS engines. These ergonomically designed knobs are very comfortable on the palm of your hand for long periods of throttling. The shorter levers and throw of the **Livorsi QR Series™** make this control great for tight dash spaces and aggressive throttling. With up to 3 trim switches integrated into the knob, your hand never has to leave the control. Electronic shifting and throttle make it easier to maneuver in tight docking spaces. Create your own color combination to make this control look and feel like a custom built control. Available in single and twin engines.

## Features

- Available with 1, 2 or 3 switches in knobs for trimming tabs, drive, jack plates or a function of your choice.
- Standard color is Chrysler Chrome\* with your choice of 10 other brilliant powder coated colors on knobs and base.
- Tube is integrated into the handle. No exposed tube for trim switch wires.
- Base plate has no screw holes exposed for a clean hi-tech look.
- Available in single and twin configurations
- DTS controls work on Mercury and Cummins DTS ready engines only.
- Easy adjustments for friction and detent. No need to remove control to adjust.

\*Chrysler Chrome is a Livorsi bright chrome billet aluminum process with double the chrome thickness and nickel to make this billet QR Series control impervious to salt water corrosion.



DTSXBS22T



DTSXBS11D

# Part Number

Use this chart below to build your part number. The example below shows a DTX Billet Straight with 1 throttle, 1 shift and one single switch.

DTSX
------

BS
Throttle Style
Code: Billet Straight   BS

1
# of Throttle Handles
Code: 1   2

1
# of Shift Handles
Code: 1   2

S
Switches
Code: no switch   single   dual   triple   S   D   T

DTSXBS11S
-----------

Final part number for this example.

\*Please call Mercury for Rigging Kits  
\*\*When ordering specify knob and base color and configuration of handles.

## Color options



## Dimensions

# of handles	"A" DIM.	"B" DIM.	"C" DIM.
2 handles	3-3/8" (8.5cm)	2-7/8" (7.3cm)	2" (5.1cm)
4 handles	5-11/16" (14.4cm)	5-3/16" (13.1cm)	4-5/16" (10.9cm)



# Electronic Sidemount Controls - Livorsi Design Capabilities

The electronic controls shown below are designed for specific OEM builders and cannot be sold at the retail level. We show these products here to highlight our design capabilities.

If you are an OEM and you require a new control for your application, please call or email us. We welcome the opportunity of designing a product for you.

## Livorsi EMC Controls (Electronic Throttle & Mechanical Shift)

- Uniquely designed for engine applications that utilize electronic throttle control yet require a cable to shift the transmission, drive, or outboard
- Throttle - Features a dual redundancy potentiometer that is fully programmable, allowing you to customize the amount of throttle output throughout the entire range
- Shift - Compatible with 33C or 43C cables

## Livorsi EEC Controls (Electronic Throttle & Shift)

- Fully electronic controls that provide a smoother and safer ride with lightning fast shifting and throttling at your fingertips
- Throttle - Features a dual redundancy potentiometer that is fully programmable, allowing you to customize the amount of throttle output throughout the entire range
- Shift - Military grade switches provide reliable gear position feedback to the engine controller
- Push button for throttle only mode with LED indication

## Both Versions Feature:

- Adjustable friction settings for throttle and shift detent
- Single or twin trim switches available to actuate wake tabs or drives
- Constructed to exceed ABYC standards
- Compatible with PCM, ILMOR and Indmar engines that support electronic throttle and shift control



Livorsi Marine provides customized controls to a number of builders:

Nautique

Centurion



MB Sports

Malibu

Tigé



# Electronic Foot Pedals - Livorsi Design Capabilities

The electronic controls shown below are designed for specific OEM builders and cannot be sold at the retail level. We show these products here to highlight our design capabilities.

If you are an OEM and you require a new control for your application, please call or email us. We welcome the opportunity of designing a product for you.

- Currently designed to control marine engines that utilize electronic throttle control
- These pedals may be calibrated for MEFI5 and 6 engines
- This completely electronic design eliminates problematic cables from bow to stern
- A sensor is used to send throttle position information from the pedal to the ECU on the engine
- Fully sealed to IP68 specifications, this sensor is waterproof and highly durable
- Plug and play waterproof Deutsch connectors simplify installation
- Solid rugged design, made of billet aluminum with an anodized finish to prevent corrosion
- Aggressive anti-slip features are built right into the pedal for confident non-slip throttling
- Private Labeling available



# Custom Wire Harness Solutions

---

Livorsi is ready to meet your short to medium run mechanical and electrical cable assembly requirements.

- Engineering design support to help maximize efficiencies
- Electro-mechanical assembly, process development, fabrication and testing
- Semi-automated wire and cable cutting and stripping for quick change-over
- Ultrasonic wire welding
- Semi-automated terminal crimping
- Custom wire labels to identify individual wires; decreases assembly time and errors
- Soldering



Komax BT 722 wire terminal crimper with crimp force technology

Livorsi utilizes state-of-the-art equipment from top manufacturers like Komax, Stapla, Cami and Shimpo.

## Cutter/Stripper

Cuts and strips wire and cable to precise programmed length.

individual wires · multi-conductor cable · wire braid · phone wire · full strip · half strip · partial strip

## Wire Terminal Crimper

A semi-automated machine that provides precise and consistent compression of wire terminals, ensuring accurate in-process crimp height, crimp force and strips. Terminal types include: Molex · AMP · Deutsch · Hirose · Others

## Ultrasonic Wire Welder

Helps reduce design time and component costs by integrating 100% quality monitored ultrasonic splice welded wires into your wire and cable harnesses. High electrical integrity with strong metallurgical bonds ensures a reliable connection between various gauges of wire.

---

In addition to in-process quality assurance, we perform 100% quality control final testing on all wire harness assemblies.

- Cable Eye Testing
- Pull Force Gauge
- LCD Video Microscope
- Value Added Wire Assembly

We can supply all harnesses needed for your OEM boat applications.

# Mechanical Sidemount Controls

## Mechanical Sidemount Features

- Now with a shorter throw - 180 degrees
- Supports outboard and sterndrive configurations with 33C cables
- Built in single trim switch controls drives, tabs wake plate, etc.
- Adjustable friction settings for throttle and shift detent
- Pull up collar design prevents accidental reverse or forward engagement
- Center button disengages shift for throttle only mode
- Available in all the standard Livorsi colors
- Custom colors available upon request

### Colors:



## Tow Sport Control (Ski Boats)

- Customizable
  - Branding
  - Colors
- Backfittable
  - Replaces Teleflex MV3



## Runabout Control

- Customizable
  - Branding
  - Colors
- Backfittable
  - Replaces Mercury MPC GEN II Panel Mount controls
  - Replaces Teleflex CH2200 + CH2300 controls

# Control Hardware & Accessories

## Trim Switches

- Replacements for Standard, Billet or ETS Controls
- These switches will not work on Mercury controls



dual with wires and plate

Trim Switches	
single no wires	TSSO
single w/ wires	TSSW
single w/ wires & plate	TSSWP + color
single w/ wire, plate & back plate	TSSWPB + color
dual w/ wires & plate	TSDWP + color
dual w/ wires, plate & back plate	TSDWPB + color

### Colors:

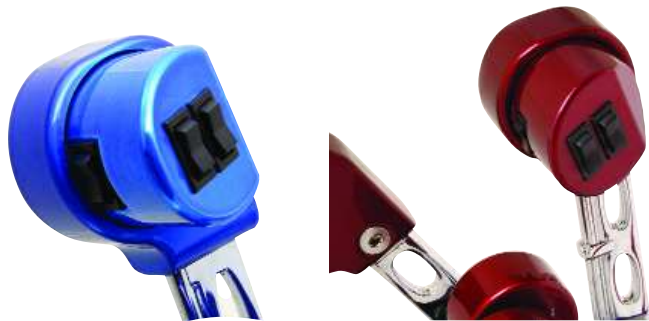

## Triple Trim Switch - bolt on

- Trim multiple drives or tabs without taking your hands off the throttle
- Ergonomic design keeps throttling arm relaxed
- Aircraft style bolt-on adds a total of 3 switches
- For left or right handed applications
- Made of billet aluminum
- Fits standard or billet controls

### Colors:



Triple Trim Switch	TTS + color
--------------------	-------------

### Neutral Safety Switch

- Allows you to start engine only when in neutral
- Included at no charge with your control order
- One needed for each shift

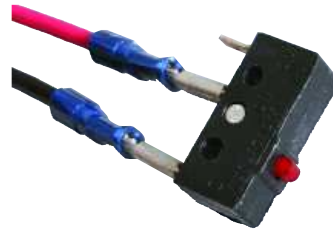

Neutral Safety Switches	
switch only	NSS
switch with wire assembly	NSSA
switch with wire assembly and screws	NSSAK

Diodes	
diode kit- diodes only	
4 piece kit for twin engine	DK
diode plug in harness- twin	DKH2
diode plug in harness- triple	DKH3

### Diode Kits

- 3 amp
- 1000V

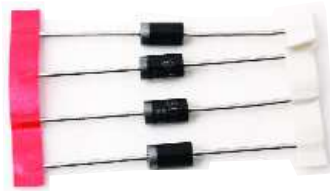

### 33C Series Cables

- Sold in two foot increments
- Sizes range from 10 feet to 38 feet
- Use with Livorsi controls or mechanical indicators
- Stainless steel core
- Chrome plated brass
- 3 1/4" throw
- Thread size 10x32



Part Number
CA + LENGTH

# Control Hardware & Accessories

## Cable Adapter Kits

- 1 kit needed for 1 throttle/1 shift lever

Description	Part Number
Mercury OB 1 shift/1 throttle	CCKOBM
Mercury I/O 1 shift/1 throttle	CCKIO
OMC OB 1 shift/1 throttle	CCKOBO
Cable Connection Kit (included at n/c with control order)	CCK30
Cable Connection Kit for 43C series cables	CCK40

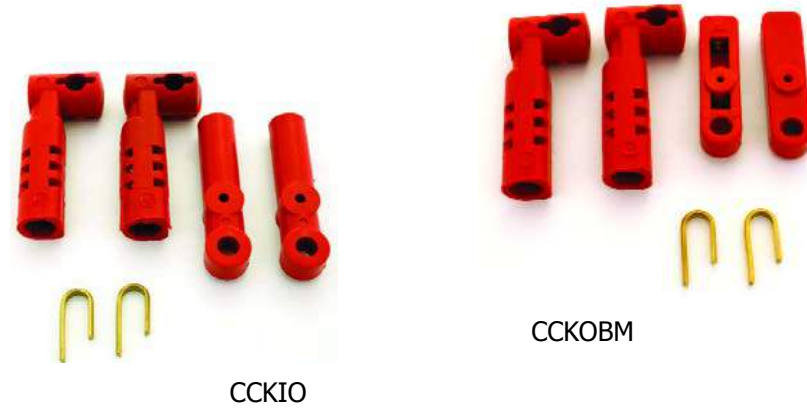

CCK30 shown here

## Throttle Bezels

- For standard, billet, ETS and arched controls
- Measures 8 1/4" long
- Width varies depending on the number of handles
- Sold separately from controls

Description	Part Number
2 handle bezel	TB2 + color
3 handle bezel (requires 2 week lead time)	TB3 + color
4 handle bezel	TB4 + color
6 handle bezel	TB6 + color

### Colors:



# Gauge Styles

---



## Industrial

dials: black or white

rims: SAE rim

Page 22

---



## Mega & Race

dials: black, platinum,  
carbon fiber, silver  
carbon fiber or white

rims: Mega or Race

Page 28

---



## Vantage View

dials: platinum, white or black

rims: Mega or Race

Page 43





# Color Options

## Dash Panels



blue carbon fiber



red carbon fiber



carbon Fiber  
CF



silver carbon fiber  
SF

## Dials

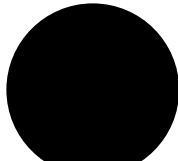

\* black- BK



carbon fiber- CF

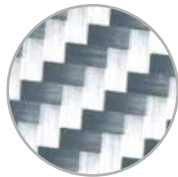

silver carbon fiber- SF

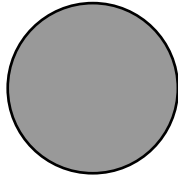

platinum- PL

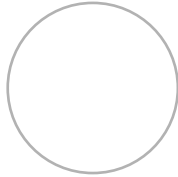

white- W

## Powder Coat Colors



\* black - BK



blue - BL



black  
stardust -  
BS



gun metal - GU

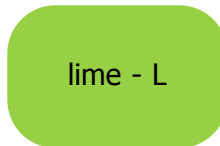

lime - L



mustard - MU



orange - O

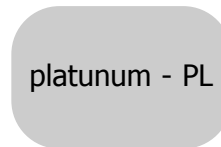

platinum - PL



polished  
stainless  
steel -  
PSS

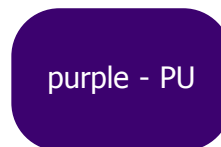

purple - PU



red - R

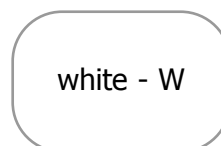

white - W

\* Black gloss finish available upon request

## Rim Styles

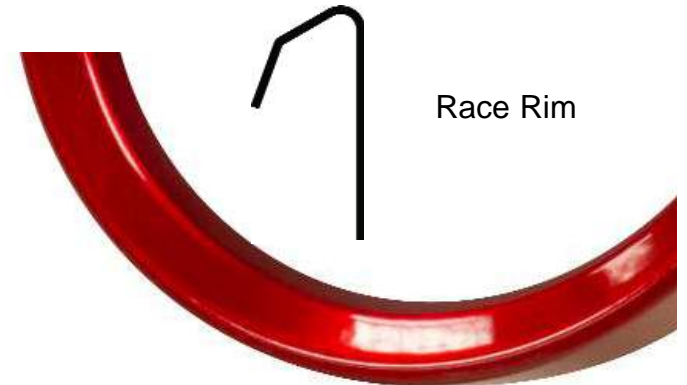

Race Rim



Mega Rim



SAE Rim

# Industrial Series

## Analog Gauges

The Industrial series was designed with the industrial equipment, workboats, pleasure boats and vehicles in mind.

Industrial Series gauges are easy to install with the use of plug-in Deutsch connectors that significantly decrease rigging time. The plug-in connectors are waterproof and resist salt corrosion and dust intrusion.

These gauges feature fade resistant powder coated pointers; SAE rims in a powder coat finish or in polished stainless steel. These finishes protect the rims and make them extremely resilient in harsh weather environments.

### Industrial Series Features

- Standard gauge sizes
- Plug-in connectors are waterproof and resist salt corrosion
- Gauges are encased in non-ferrous hardware
- Red LED lighting is standard
- Available in 12 or 24 volt system
- Powder coated pointers are fade resistant
- SAE rims in flat black, white or stainless steel

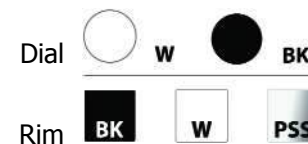
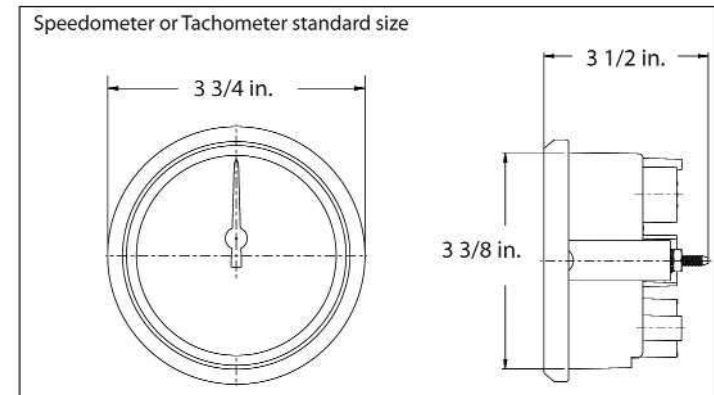
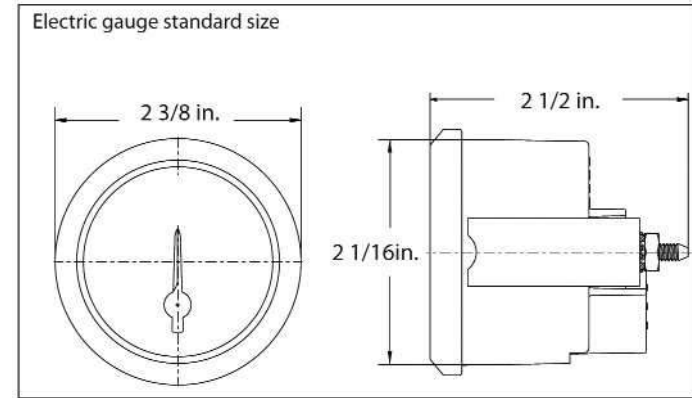

# Industrial Series

## Tachometers

Gas tachometers are compatible with:  
4, 6, & 8 cylinder, V-10 & Merc O/B 6 pulse/12 pole



6,000 RPM



8,000 RPM



10,000 RPM



12,000 RPM

cutout size: 3 3/8"		overall size: 3 3/4"
Tachometers - Gas		
Description	Base Part Number	Requires
6,000 RPM	DCS6000	DCH harness
8,000 RPM	DCS8000	DCH harness
10,000 RPM	DCS10000	DCH harness
12,000 RPM	DCS12000	DCH harness



DCH



4,000 RPM

Tachometer Hardware	
Description	Part Number
DCH harness 12V 24" lead	DCH
DCH harness 24V 24" lead	DCH24
DCH harness 12V w/ tach filter, reduces needle bounce, 24" lead	DCTFH

cutout size: 3 3/8"		overall size: 3 3/4"
Tachometers- Diesel 4000 RPM		
Description	Base Part Number	Requires
alt driven	DC4000DA	DCH harness
mag probe driven	DC4000MPD	DCH harness
mechanical signal generator driven	DC4000MSGD	DCH harness

# Industrial Series

## GPS Speedometers

- Livorsi GPS Speedometers require a NMEA 0183 antenna/receiver.

### Included with GPS Speedometer

- speedometer
- memory recall
- harness

### Included with GPS Speedometer Kit

- speedometer
- memory recall
- harness
- GPS antenna
  - antenna mounts with a 1/4" screw
  - antenna dimensions: 2 3/4" L x 2 3/8" W x 7/8" H

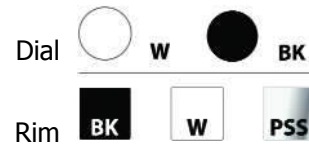

cutout size: 3 3/8"		overall size: 3 3/4"
Description	Base Part Number	Notes
50 MPH	GPSS50	For a GPS Kit, add the letter "K" after the MPH.
60 MPH	GPSS60	
80 MPH	GPSS80	
100 MPH	GPSS100	
120 MPH	GPSS120	
140 MPH	GPSS140	
160 MPH	GPSS160	
180 MPH	GPSS180	
200 MPH	GPSS200	



GPS antenna



50 MPH



60 MPH



80 MPH



100 MPH



120 MPH



140 MPH



160 MPH



180 MPH



200 MPH

# Industrial Series

## Mechanical Gauges



boost 0-35 PSI



fuel pressure 0-15 PSI



fuel pressure 0-100 PSI



oil pressure 0-100 PSI



hose kit



vacuum boost



water pressure 0-35 PSI



water pressure 0-60 PSI

cutout size: 2 1/16"

overall size: 2 3/8"

Description	Base Part Number	Requires
Boost 0-35 PSI	DCSMB35	hose kit
Fuel Pressure 0-15 PSI	DCSMFP	fuel hoses n/a
Fuel Pressure 0-100 PSI	DCSMFP100	
Oil Pressure 0-100 PSI	DCSMOP	hose kit
Vacuum/Boost 30 in hg/boost20	DCSMVB	hose kit
Water Pressure 0-35 PSI	DCSMWP	hose kit
Water Pressure 0-60 PSI	DCSMWP60	hose kit
Hose Kits - not to be used with fuel		
10 feet of hose and fittings	HKA	
25 feet of hose and fittings	HK	

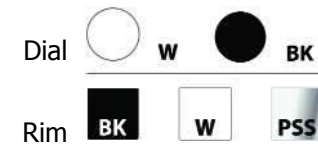

# Industrial Series

## Electric Gauges

- These electric gauges require the use of a four pin connector wire harness (unless otherwise noted) that we call a DCH harness.
- We offer these harnesses pre-assembled with labeled wire leads, 24 inches in length.

cutout size: 2 1/16"		overall size: 2 3/8"	
Description	Base Part Number	Requires	
Fuel Level 0-90 OHMS	DCSFLGM	DCH/DCH24, fuel level sender	
Fuel Level 240-33 OHMS	DCSFL	DCH/DCH24, fuel level sender	
Fuel Pressure 0-15 PSI	DCSFP	DCH/DCH24, GSFP/WP	
Fuel Pressure 0-90 PSI	DCSFP90	DCH/DCH24, GSFP60/90	
Hourmeter	HM *	-	
Oil Pressure 0-80 PSI	DCSOP80	DCH/DCH24, GSOP80	
Oil Temperature 140-340° F	DCSOT	DCH/DCH24, GSOT1/8	
Transmission Temp 140-340° F	DCSTT	DCH/DCH24, GSOT1/8	
Trimmer Merc & Yamaha 10-90 OHMS	DCSTMM	DCH/DCH24	
Trimmer OMC 88-1 OHMS	DCSTMO	DCH/DCH24	
Voltmeter 8-18V	DCSVM	DCH/DCH24	
Voltmeter 18-32V	DCSVM24	DCH/DCH24	
Water Level	DCSWL	DCH/DCH24, water level sender	
Water Temperature 100-250° F	DCSWTA	DCH/DCH24, GSOT1/8	
Water Temperature 100-280° F	DCSWT	DCH/DCH24, GSWT1/8	
<b>DCH Harnesses- pre-assembled</b>			
12 volt system, 24 inch leads	DCH		
24 volt system, 24 inch leads	DCH24		

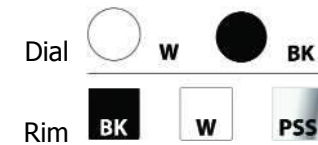

\* Note: Available with Mega or Race Rim only.

# Industrial Series

## Electric Gauges



boost 60 PSI



fuel level



fuel pressure 0-15 PSI



fuel pressure 0-90 PSI



hourmeter \*



oil pressure 0-80 PSI



oil temperature  
140-340° F



transmission temp  
140-340° F



trimmer



voltmeter 8-18 V



voltmeter 8-32 V



water level



water temperature  
100-250° F



water temperature  
100-280° F

# Mega & Race Series

## Analog Gauges

### Features

- Standard size or oversize
- Plug-in connectors are waterproof and resist salt corrosion
- Gauges are encased in non-ferrous hardware
- Red LED lighting is standard; for easy viewing in low light conditions
- Available in 12 or 24 volt system
- Your choice of rim style: Mega or Race

### Custom Options

- Dial color
- Needle color
- Private label



Race Rim - RR

Mega Rim - MR

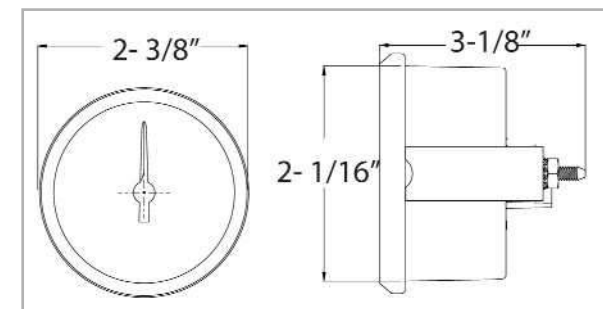
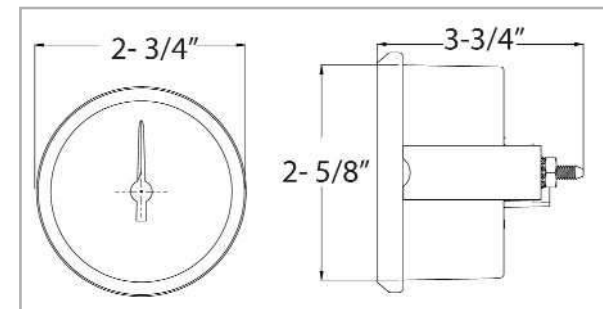
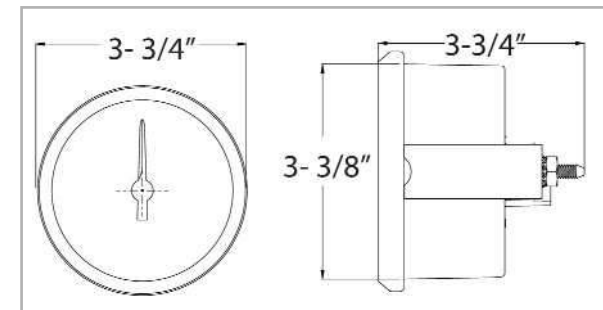
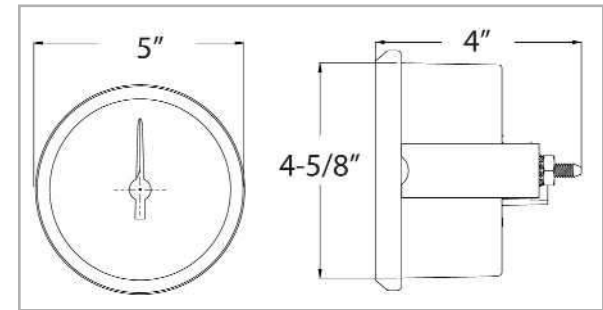



# Mega & Race Series

## Tachometers

Gas Tachometers are compatible with:  
4, 6, & 8 cylinder, V-10, Merc O/B, 6 pulse/12 pole

Gas Tachometers				
Description	Part Number			Requires
	2 5/8"	3 3/8"	4 5/8"	
6,000 RPM	-	DCS6000	DCL6000	DCH harness
8,000 RPM	MT8000	DCS8000	DCL8000	DCH harness
10,000 RPM	-	DCS10000	DCL10000	DCH harness
12,000 RPM	-	DCS12000	-	DCH harness

Diesel Tachometers			
Description	Part Number		Requires
	3 3/8"		
4,000 RPM alt driven	DC4000 DA		DCH harness
4,000 RPM mag probe driven	DC4000 MPD		DCH harness
4,000 RPM mech signal generator driven	DC4000 MSGD		DCH harness

### 4 Pin Connector & Wire Harness

- 24 inches in length
- Pre-assembled and labeled

Tachometer Hardware	
Description	Part Number
DCH harness 12V 24" lead	DCH
DCH harness 24V 24" lead	DCH24
DCH harness 12V w/ tach filter, reduces needle bounce	DCTFH



6000 RPM



8000 RPM



10000 RPM



12000 RPM



4000 RPM



DCH

# Mega & Race Series

## GPS Speedometers

Purchase GPS Speedometer only, you get:

- speedometer
- memory recall
- harness for power, ground and back lighting

GPSSQ310X antenna

- Mounts with a 1/4" screw
- Dimensions: 2 3/4" L x 2 3/8" W x 7/8" H
- Fast 10 Hz 10x per second update
- 4 ft harness and ring terminals

GPS Speedometer Kit includes

- speedometer
- memory recall
- harness for power, ground and back lighting
- NMEA 0183 antenna - GPSSQ310X



### Build your part number:



GPS | S | 50 | K | PL | PL | RR  
 size | speed | kit | dial color | rim color | rim style

Description	Part Number		Requires
	3 3/8"	4 5/8"	
50 MPH	GPSS50	GPSL50	For a GPS Kit, add the letter "K" after the MPH.
60 MPH	GPSS60	GPSL60	
80 MPH	GPSS80	GPSL80	
100 MPH	GPSS100	GPSL100	
120 MPH	GPSS120	GPSL120	
140 MPH	GPSS140	GPSL140	
160 MPH	GPSS160	GPSL160	
180 MPH	GPSS180	GPSL180	
200 MPH	GPSS200	GPSL200	
GPS antenna	GPSSQ310X	NMEA 0183 antenna - square body	

# Mega & Race Series

GPS Speedometers



50 MPH



60 MPH



80 MPH



100 MPH



120 MPH



140 MPH



160 MPH



180 MPH



200 MPH

Dial W PL BK CF SF

Rim BK BL BS GU L MU O PL PSS PU R W

# Mega & Race Series

## Speedometers



DCMS60



DCMS80



DCMS100

### Speedometer Hoses

Description	Part Number
1/8" ID push on high pressure	GCH1/8
1/4" ID push on high pressure	GCH1/4

### Dry Speedometers

Description	Part Number		Requires
	3 3/8"	4 5/8"	
60 MPH	DCMS60		pitot tube, hose & mounts
80 MPH	DCMS80	DCML80	
100 MPH	DCMS100	DCML100	Add "K1" for a kit

You may request dials in any of our powdercoat colors, extra fees apply.



# Mechanical Speedometer Hardware

## Mechanical Speedometers



### Recoil Blade Kickup

Description	Part Number
blade only 5"	GCRB
blade fitting 1/4" ID hose	GCF8
blade fitting 1/8" ID hose	GCPM1/8



### Low Profile Blade Assembly

Description	Part Number
regular	GCRB1A
90° angle	GCRB1A90



### Blade Assembly Standard

Description	Part Number
universal bolt pattern	GCM1A
Mercury bolt pattern	GCM2A



### Mercury Reverse Mount Assembly

Description	Part Number
with fittings	GLRMA
with out fittings	GLRM



### Kick Up Mount

Description	Part Number
1/4" ID hose	GLM1A
1/8" ID hose	GLM1A1/8

### Blades

standard blade 7"	GCT1
blade 5" for GCRB1A / RBM2A	GCRB
<b>Thru hull fittings</b>	
2" x 1/8" NPT	THF21/8
4" X 1/8" NPT	THF41/8
90° fitting 1/8" NPT male push lock x 1/4" ID push lock	GCF6
<b>Blade mounts</b>	
tube or blade mount	GCM3
<b>Hoses</b>	
1/8" ID push on high pressure	GCH1/8
1/4" ID push on high pressure	GCH1/4

# Mega & Race Series

## Electric Gauges

- These electric gauges require the use of a four pin connector wire harness (unless otherwise noted) that we call a DCH harness.
- We offer these harnesses pre-assembled with labeled wire leads, 24 inches in length.

Description	Part Number		Requires
	2 1/16"	2 5/8"	
Clock	-	DCC	DCH harness
Fuel Level 0-90 ohms	DCSFLGM	DCFLGM	DCH, fuel level sender
Fuel Level 240-33 ohms	DCSFL	DCFL	DCH, fuel level sender
Fuel Pressure 0-15 PSI	DCSFP	DCFP	DCH, GSFP/WP
Fuel Pressure 0-90 PSI	DCSFP90	DCFP90	DCH, GSFP60/90
Hourmeter	HM	-	-
Oil Pressure 0-80 PSI	DCSOP80	DCOP80	DCH, GSOP80
Oil Pressure 0-100 PSI	DCSOP	DCOP	DCH, GSOP
Oil Temperature 140-340° F	DCSOT	DCOT	DCH, GSOT1/8
Transmission Temp 140-340° F	DCSTT	DCTT	DCH, GSOT1/8
Trimmer Merc & Yamaha 10-90 ohms	DCSTMM	DCTMM	DCH
Trimmer OMC 88-1 ohms	DCSTMO	DCTMO	DCH
Voltmeter 8-18V	DCSVM	DCVM	DCH
Water Level	DCSWL	DCWL	DCH
Water Temperature 100-250° F	DCSWTA	DCWTA	DCH, GSOT1/8
Water Temperature 100-280° F	DCSWT	DCWT	DCH, GSOT1/8
<b>DCH Harnesses</b>			
12 volt system, 24 inch leads	DCH		
24 volt system, 24 inch leads	DCH24		

Dial  W  PL  BK  CF  SF

Rim  BK  BL  BS  GU  L  MU  O  PL  PSS  PU  R  W



# Mega & Race Series

## Electric Gauges



clock



oil pressure 80 PSI



fuel level



fuel pressure 15 PSI



fuel pressure 90 PSI



hourmeter



oil pressure 100 PSI



oil temperature



transmission temperature



trimmer



voltmeter



water level



water temperature 250 F



water temperature 280 F

# Mega & Race Series

## Mechanical Gauges

Description	Part Number		Requires
	2 1/16"	2 5/8"	
Boost 0-35 PSI	DCSMB35	DCMB35	hose kit
Fuel Pressure 0-15 PSI	DCSMFP	DCMFP	fuel hoses n/a
Fuel Pressure 0-100 PSI	DCSMFP100	DCMFP100	
Oil Pressure 0-100 PSI	DCSMOP	DCMOP	hose kit
Vacuum/Boost 30 in hg/boost 20	DCSMVB	DCMVB	hose kit
Water Pressure 0-35 PSI	DCSMWP	DCMWP	hose kit
Water Pressure 0-60 PSI	DCSMWP60	DCMWP60	hose kit



### Hose Kit

- not for fuel
- use with mechanical gauges
- 1/8" ID

Description	Part Number
25 feet with fittings	HK
10 feet with fittings	HKA



vacuum boost



boost



fuel pressure 15 PSI



fuel pressure 100 PSI



oil pressure 100 PSI



water pressure 35 PSI



water pressure 60 PSI



## 4 Pin Connector & Wire Harness

- 24 inches in length
- Pre-assembled and labeled

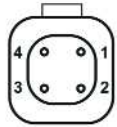

Pin # 1 = BLUE 12v+ illumination  
 Pin # 2 = VIOLET 12v+ ignition power  
 Pin # 3 = BLACK engine or battery ground  
 Pin # 4 = GREEN signal from sender



DCH Harness	Part Number
12 volt system	DCH
24 volt system	DCH24
12 volts w/ tach filter	DCTFH

Connector Parts	
Description	Part Number
2 Pin - mechanical lights	
2 pin connector plug	DC2CPLUG
2 pin connector wedge lock	DC2CWL
4 Pin - electrical gauges	
4 pin connector plug	DC4CPLUG
4 pin connector wedge lock	DC4CWL
8 Pin - power distribution	
8 pin connector plug	DC8CPLUG
8 pin connector wedge lock	DC8CWL
12 Pin - power distribution	
12 pin connector plug	DC12CPLUG
12 pin connector wedge lock	DC12CWL
dummy plug	DCDP
contacts for 16 gauge wire	DCC1416
Hand Crimper	DCHCS

Description	Part Number
Senders	
Fuel Pressure 0-60 PSI / 0-90 PSI	GSFP60/90
Fuel & Water Pressure 0-15 PSI	GSFP/WP
Isolated Ground for Water Temperature	GSWT1/8I
Oil Pressure 0-80 PSI	GSOP80
Oil Pressure 0-100 PSI	GSOP
Oil / Water Temperature 100-320°F	GSOT1/8
Water Temperature 100-250°F 1/8" thread	
Pressure 400 PSI	GSP400
Water Temperature- Merc OB Kit	GSWTM
Water Temperature 100-280°F 1/8" thread	GSWT1/8
Bushing Kit 1 /4", 3/8" and 1/2" fittings	GSBKK1
Hose Kit for Mechanical Gauges not to be used with fuel, 1/8 in ID	
10 feet of hose and fittings	HKA
25 feet of hose and fittings	HK

Description	Part Number
LED Wedge	
amber 12.8V	LEDWA
blue 12.8V	LEDWBL
green 12.8V	LEDWG
red 12.8V	LEDWRB
white 12.8V	LEDWW
Clamshells	
for 1/4" id hose black	GCCS1/4BK
for 1/4" id hose white	GCCS1/4W
for 1/2" id hose white	GCCS1/2W

# GPS Antennas

## GPS Antenna for Vantage View®

Part Number: GPSRAQ3VV

- Antenna is NMEA 0183 compliant
- 2 3/4" L x 2 3/8" W x 7/8" H
- Standard 1-second 1HZ update
- 4 ft harness and ring terminals
- Pre-terminated for quick connection to the Vantage View Master Harness
- It is recommended to use this model number for full compliance with Livorsi Vantage View® speedometers



## GPS Antenna

Part Number: GPSSQ3

- Antenna is NMEA 0183 compliant
- 2 3/4" L x 2 3/8" W x 7/8" H
- Standard 1-second 1HZ update
- 4 ft harness and ring terminals
- It is recommended to use this model number for full compliance with Livorsi GPS speedometers
- Compatible with SmartCraft®



## GPS Antenna for non-GPS speedometers

Part Number: GPSESQ3

- Antenna is NMEA 0183 compliant
- 2 3/4" L x 2 3/8" W x 7/8" H
- Fast 10 Hz 10x update -8/16 pulse output
- 4 ft harness and ring terminals
- For use with existing automotive or commercial electric speedos (non-GPS speedo heads)

## GPS Antenna with 10X per second update

Part Number: GPSSQ310X

- Antenna is NMEA 0183 compliant
- 2 3/4" L x 2 3/8" W x 7/8" H
- Fast 10 Hz 10x per second update
- 4 ft harness and ring terminals

# GPS Speedometer w/ Odometer

For automotive or marine applications, this stand alone GPS speedometer is a digital gauge with an analog readout and a built in LCD odometer. Designed to be hassle free, this gauge relies on GPS satellite signals to display accurate speed and miles traveled, so there is no need to calibrate this gauge with gear ratios or tire size.

## Gauge Features

- Digital odometer helps you determine your GPM
- Eliminates the need for cables
- No calibration required
- LCD displays odometer and 3 resettable trip odometers
- 10x update for accurate readings
- 120 MPH or 160 MPH

## Gauge Kit Includes:

- Gauge head
- GPS antenna with 10 Hz 10x update
- Switch
- Harness
- Mounting hardware

cutout size	overall size
3 3/8"	3 3/4"
4 5/8"	5"



Description	Gauge Kit Part Number
	3 3/8" cutout
120 MPH	GPSSO120K + dial color + rim color + style
160 MPH	GPSSO160K + dial color + rim color + style
	4 5/8" cutout
120 MPH	GPSLO120K + dial color + rim color + style
160 MPH	GPSLO160K + dial color + rim color + style



## GPS Antenna 10X Update

- Antenna is NMEA 0183 compliant
- 2 3/4" L x 2 3/8" W x 7/8" H
- Fast 10 Hz 10x update
- 4 ft harness and ring terminals

Part Number: GPSSQ310X



# Depth Finder Gauge

## Gauge Features

- Larger LCD digits
- Algorithmic programming
- Instant depth updates
- Easy touch programming
- Keel offset
- English & Metric readings
- Dual depth alarms
- Advanced warning system
- Memory retention
- Polarized LCD
- Plug & Play connectors
- Red LED alarm light



Shoot Thru  
(uses epoxy)



Transom

## Gauges Specs

- 1 7/8" cutout, 2 1/2" overall
- Green backlighting
- 11-14Vdc
- Readout: min. -2.5 feet / max. 200 feet
- Red LED and blinking LCD icons for alarms
- Transducers have 30" lead

## Gauge Kit Includes

- gauge
- transducer
- mounting brackets
- epoxy (for shoot thru only)

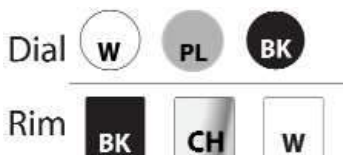

Description	Part Number
Depth Only Gauge	
head only	DFG + color rim
Kit - Gauge and shoot thru transducer	DFGKST + color rim
Kit - Gauge and transom mount transducer	DFGKTR + color rim
Transducers - Depth Only	
shoot thru transducer	TST
transom mount transducer	TTR
Depth - Air - Water Gauge	
head only	DISCONTINUED
Kit - Gauge and Transom mount transducer	DISCONTINUED
Transducers - Depth Air Water	
transom mount transducer	DISCONTINUED



For  
SmartCraft®,  
NMEA 2000®,  
SAE J1939 and  
GM MEFI engines



The Vantage View® system comprises of a Master Tachometer that reads information directly from the ECM/ECU. The Master Tachometer contains a LCD screen in which the user is able to view the performance data, Faults and Warnings of the boat or vehicle. All Vantage View® gauges utilize 270° digital stepper motors that accurately display data in real time. While these instruments are digital, they were designed with the traditional styling of analog gauges. Fluorescent fade resistant pointers and large bold graphics make these instruments easy to ready at a glance.

User programmable warning alarms, simplified rigging and rugged construction makes this line of instruments an exceptional tool for monitoring the performance of a vehicle, workboat or powerboat.

### **Each engine requires its own Master Tach and daisy chains to slave gauges**

- Each LCD displays up to 10 engine functions such as water temp, oil press, GPH, etc.
- Designed to work with SmartCraft®, NMEA 2000®, SAE J1939 and GM MEFI protocols
- For automotive, industrial or marine applications
- Control module may be mounted in location of your choosing to navigate through the LCD screen
- Available in sizes 2, 3, 4 and 5"

### **Carbon Fiber and Silver Carbon Fiber dials**

We've added the popular carbon fiber and silver carbon fiber dial option to our Vantage View gauge series.



# Vantage View®



## Four Function Gauge

The 4-in-1 gauge saves you dash space by combining 4 essential functions into one 5" gauge: oil pressure, water temperature, volts and fuel level.

## Speed

Vantage View® reads both CAN (NMEA 2000® and SAE J1939) and serial (NMEA 0183) based speed inputs.

## Programmable Alarms

In addition to factory set Fault and Warnings, users can tailor up to 15 alarms to their individual needs. When triggered, pop-up alerts appear on the LCD screen and the bright LED warning light illuminates on the corresponding slave gauge.

## Pop Up Alerts

Enabling of popup alerts for faults, warnings or alarms provides a highly visible alert screen when a fault, warning or alarm occurs. Popups may be enabled for engine trim/tabs brings up a trim detail screen when a change in trim position occurs. Vantage View® even displays Engine Diagnostic Codes for J1939.

## Faults and Warnings

Vantage View® alerts you of Faults and Warnings with blinking icons on the Master Tachometer LCD screen. Faults are a problem reported by the ECM/ECU that warrants stopping the engine. Warnings alert you of potential problems as reported by the ECM/ECU.

## Fuel Tank and Engine Trim Calibration

The Vantage View® system is the ability to calibrate the fuel tank and engine trim, ensuring utmost accuracy. The Master Tachometer can monitor up to two fuel tanks with the option to use an analog signal or CAN Bus information. The Engine Trim feature also allows for one analog or one CAN Bus signal.

## Rim Options

Low Profile Rim



Mega Rim



Race Rim



# Vantage View<sup>®</sup>

## Can Bus Gauges

Master Tach, Slave Speedometer or Four in One

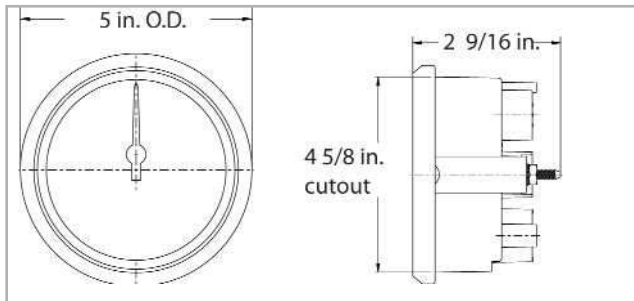

Master Tach or Slave Speedometer or Four in One

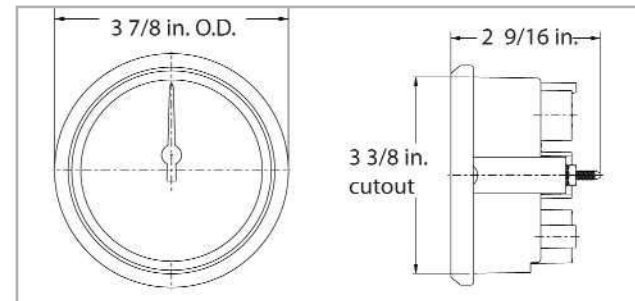

2-1/2" Slave Gauges

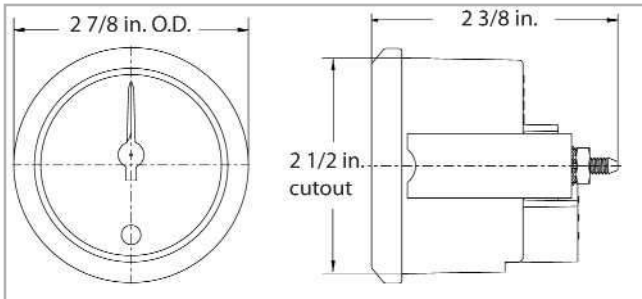

2-1/8" Slave Gauges and FWA gauge

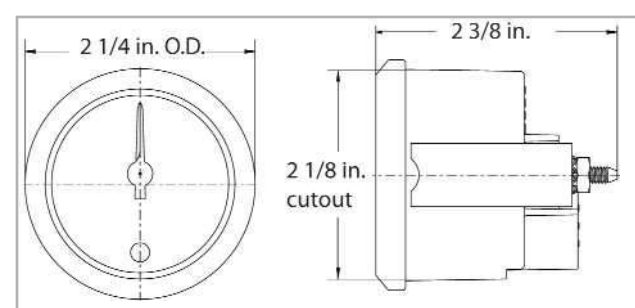



# Vantage View®

Can Bus Gauges

Each engine requires its own Master Tachometer

- LCD displays up to 10,000 RPM
- Up to 6 slave gauges may be daisy chained to the Master Tachometer
- Marine configured tachs display "Total Hours"
- Automotive/industrial configured tachs display "Total Miles"
- Have the ability to record and reset three trip logs
- The user can set up 10 parameters of their choice to display in the main screens. Choose between single or three parameter display.

Menu navigation requires the use of either a control pod (controls up to 4 engines) or the VV switch control module.



control pod



switch control module



VJS7KPLPLR



VJS4KBKPLR

Master Tachometer - SmartCraft® protocol		
Description	Part Number	
	3 3/8"	4 5/8"
4000 RPM	VSCS4K	VSCL4K
7000 RPM	VSCS7K	VSCL7K

Master Tachometer - NMEA 2000®, J1939 & MEF14 protocol		
Description	Part Number	
	3 3/8"	4 5/8"
4000 RPM	VJS4K	VJL4K
7000 RP	VJS7K	VJL7K

Analog Input- Resistance Ranges	
Description	Resistance Ranges- ohms
Fuel Level 1	240-33, 10-180, 0-90
Fuel Level 2	240-33, 10-180, 0-90
Fresh Water Level	240-33, 10-180, 0-90
Waste Water Level	240-33, 10-180, 0-90
Engine Oil Level	240-33, 10-180, 0-90
Transmission Oil Level	240-33, 10-180, 0-90
Hydraulic Oil Level	240-33, 10-180, 0-90
Coolant Level	240-33, 10-180, 0-90
Washer Fluid Level	240-33, 10-180, 0-90
Generic Level	240-33, 10-180
Boost Pressure	240-33, 10-180
Block Pressure	240-33, 10-180
Fuel Delivery Pressure	240-33, 10-180
Engine Oil Pressure	240-33, 10-180
Transmission Oil Pressure	240-33, 10-180
Hydraulic Oil Pressure	240-33, 10-180
Brake Application Pressure	240-33, 10-180
Brake Primary Pressure	240-33, 10-180
Brake Secondary Pressure	240-33, 10-180
Generic Pressure	240-33, 10-180
Outside Air Temperature	10K Thermistor (Airmar T-80)
Inside Air Temperature	10K Thermistor (Airmar T-80)
Water Temperature	10K Thermistor (Airmar T-80)
Trim	240-33, 10-180, 0-90, 167-10
Steering Angle	240-33, 10-180, 0-90
Rudder Angle	240-33, 10-180, 0-90
Front Air Pressure	240-33, 10-180, 0-90
Rear Air Pressure	240-33, 10-180, 0-90

Faults or Warnings		
Description		Faults or Warnings
Warning Over Heat	Over-heat	W
Warning Low Oil Pressure	Low Oil Press	W
Warning Low Voltage	Low Voltage	W
Warning High Voltage	High Voltage	W
Warning Over Speed	Over Speed	W
Warning Water in Fuel	Fuel	W
Warning Guardian Active	Guard Active	W
Warning Check Engine	Check Engine	W
Oil Fault	Oil	F
Guardian/Check Engine Fault	Guard/Ck Eng	F
CAN Fault	CAN Bus	F
Water in Fuel Fault	Fuel	F
Voltage Fault	Voltage	F
Coolant Temperature Fault	Coolant Temp	F

### Single Engine Switch Control Module

- Controls one Master Tachometer
- One assembly needed per engine
- Requires two 1/2 in. cutout for toggle switches

VVSAW assembly includes:

- Two switches & two boots
- DCC contacts for easy installation

Description	Part Number
switch control module	VVSAW
plate only (2 3/4 in diam.)	PSSP + color
mode switch only	TSMF
up/down switch only	TSMFM
black switch boot	TSRBBK



switch control module



switch control module with optional plate

### Control Pod

- Control up to 4 Master Tachometers with one pod
- Uses waterproof momentary buttons
- Twin, triple and quad control pods have a polished selector knob to toggle between Master Tachometers

Description	Part Number
single engine	VVCPSA + color
twin engine	VVCPPTA + color
triple engine	VVCPTRA + color
quad engine	VVCPQA + color



Control Pod twin engine

### Control Pod Dimensions

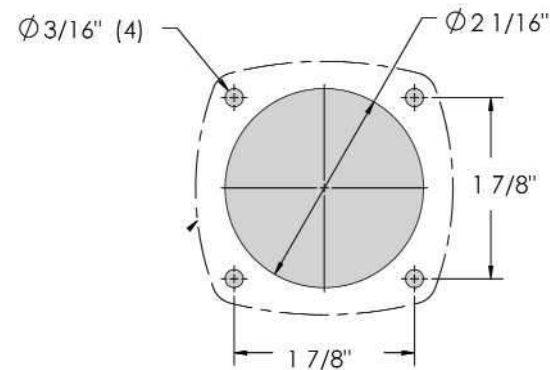

### Colors:



# Vantage View®

## Harnessing

SmartCraft® Master Harness  
length: 36 in. ± .5 in.

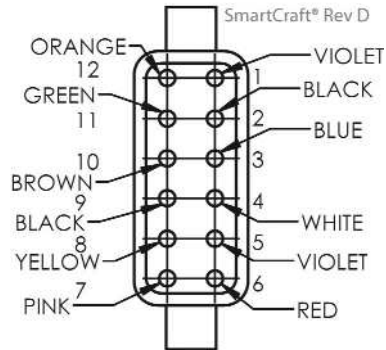

Part Number		VVMHSC
Wire Label		
Number	Color	Label
7	Pink	Analog
8	Yellow	NMEA 0183

SAE J1939/Indmar Master Harness  
length: 36 in. ± .5 in.

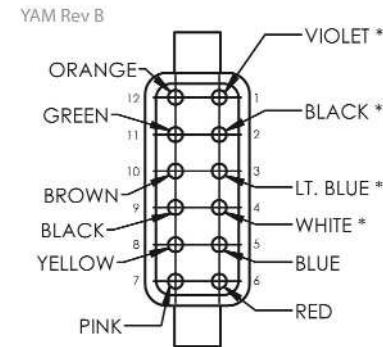

Part Number		VVMHJI
Wire Label		
Number	Color	Label
1	Violet	Switched Positive
2	Black	Ground
3	Lt. Blue	CAN L
4	White	CAN H
5	Blue	Lighting
6	Red	Battery
7	Pink	Analog
8	Yellow	NMEA 0183
9-12	-	to amp connector

NMEA 2000® Micro C Female Master Harness  
length: 36 in. ± .5 in.

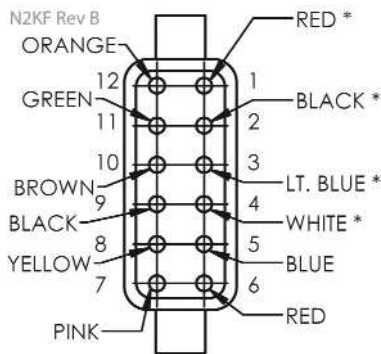

Part Number		VVMHN2KF
Wire Label		
Number	Color	Label
5	Blue	Lighting
6	Red	Battery
7	Pink	Analog
8	Yellow	NMEA 0183

NMEA 2000® Micro C Male Master Harness  
length: 36 in. ± .5 in.

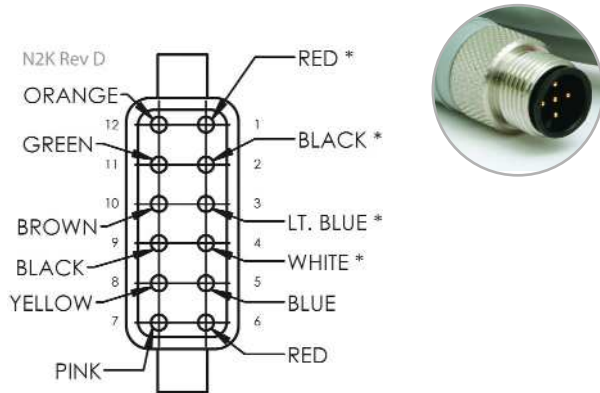

Ilmor Micro C Male Master Harness  
length: 36 in. ± .5 in.

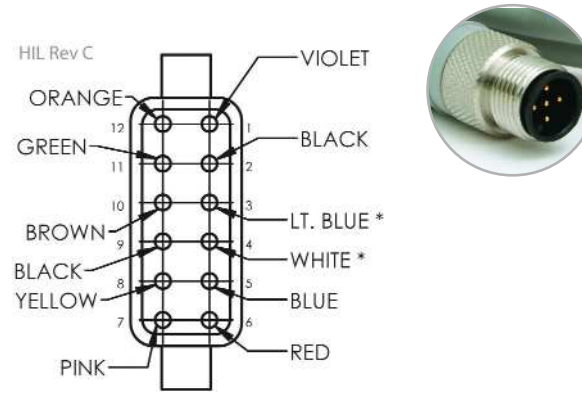

Part Number		VVMHN2K
Wire Label		
Number	Color	Label
5	Blue	Lighting
6	Red	Battery
7	Pink	Analog
8	Yellow	NMEA 0183

Part Number		VVMHIL
Wire Label		
Number	Color	Label
1	Violet	Switched Positive
2	Black	Ground
5	Blue	Lighting
6	Red	Battery
7	Pink	Analog
8	Yellow	NMEA 0183



Long Slave Harness		
Description	Length	Part Number
2 gauge	27 1/2 in.	VVSH2L
4 gauge	53 1/2 in.	VVSH4L
6 gauge	78 1/2 in.	VVSH6L

Short Slave Harness		
Description	Length	Part Number
2 gauge	17 in.	VVSH2S
4 gauge	37 1/2 in.	VVSH4S
6 gauge	54 1/2 in.	VVSH6S

# Vantage View®

## Slave Speedometers



60 MPH



80 MPH



100 MPH



120 MPH

The speedo receives data from the Master Tach which can be from the following:

- CAN message
- Paddle wheel
- GPS signal- uses the A/D digital input available on the Master Tach.  
The GPS source must be wired to the proper pin of the 12 pin connector of the Master Tach.

Both the paddle wheel and GPS antenna must be NMEA 0183 compliant.

Note: Vantage View requires the use of GPS antenna part number: GPSRAQ3VV.  
Other GPS antenna models may not work with Vantage View.



160MPH



Description	Part Number		
	3 3/8"	4 5/8"	
60 MPH	VJS60	VJL60	For a kit add "K" after the MPH
80 MPH	VJS80	VJL80	
100 MPH	VJS100	VJL100	
120 MPH	VJS120	VJL120	
160 MPH	VJS160	VJL160	
180 MPH	VJS180	VJL180	
GPS antenna for Vantage View	GPSRAQ3VV		

Dial W PL BK CF SF

Rim BK BL BS GU L MU O PL PSS PU R W

### FWA Gauge

This gauge provides five discrete illuminated visual indicators and multiple outputs. Outputs include a dedicated audible alarm and one set of relay output contacts for secondary alarms or additional engine protection devices.





This FWA gauge is needed in order for Vantage View® to receive built in Faults and Warnings from Cummins Diesel engines when a Diesel View display is not present.

FWA gauge will work on all engine protocols except for Mercury Gas SmartCraft® engines.

Available with a black dial only. 2 1/8" cutout

Description	Part Number
fwa gauge	VJSFWABK + rim color + style



Color Codes	
Dial	 BK
Rim	 BKR  PLR  PSR





### Four Function Gauge

Save dash space with this four function gauge:

- Oil pressure
- Water temperature
- Volts
- Fuel level

Description	Part Number
3 3/8" cutout	VJS4K + dial color+ rim color + rim style
4 5/8" cutout	VVJN14F + dial color+ rim color + rim style



Dial	W	PL	BK	CF	SF							
												
Rim	 BK	 BL	 BS	 GU	 L	 MU	 O	 PL	 PSS	 PU	 R	 W

# Vantage View®

## Slave Gauges

NMEA 2000® , SmartCraft® , GM MEFI and J1939		
Description	Part Number	
	Small 2 1/8"	Large 2 1/2"
boost 0-35 PSI	VJSB	VJLB
fuel level 1	VVJNISFL1	VVJNILFL1
fuel level 2*	VVJNISFL2	VVJNILFL2
fuel pressure 90 PSI	VJSFP90	VJLFP90
oil level 1	VVJNISOL1	VVJNIOLO1
oil level 2*	VVJNISOL2	VVJNIOLO2
oil pressure 0-80 PSI	VVJNISOP	VVJNIOLOP
oil temperature 0-280°F	VVJNISOT	VVJNIOLOT
trim drive port (left)	VVJNISTDP	VVJNILTDP
trim drive stbd (right)	VVJNISTDS	VVJNILTDS
voltmeter 10-16V	VVJNISVM	VVJNILVM
water pressure 30 PSI	VVJNISWP30	VVJNILWP30
water pressure 60 PSI	VVJNISWP60	VVJNILWP60
water temperature 100-240°F	VVJNISWT	VVJNILWT

Note: \* Available for Smartcraft only

NMEA 2000® - Ilmor compliant		
Description	Part Number	
	Small 2 1/8"	Large 2 1/2"
voltmeter- alternator 10-16V	VVNISVMA	VVNILVMA
water pressure 30 PSI	VNSWP30C	VNLWP30C
water pressure 60 PSI	-	VNLWP60C



boost 0-35 PSI



fuel level 1



oil pressure 0-80 PSI



oil temperature 100-280° F



water pressure 0-60 PSI



water temperature 100-240° F





fuel level 2



fuel pressure 0-90 PSI



oil level 1



oil level 2



trim drive port (left)



trim drive starboard (right)



voltmeter 10-16



water pressure 0-30 PSI

### Vantage View Slave Gauges

- Slave gauges must be connected to the Master Tachometer via the slave harness daisy chain
- 270 degree sweep with digital stepper motors
- LED warning lights illuminate when programmed alarms are triggered (setup through the Master Tachometer)
- Fluorescent orange pointers
- Back lit with red LED lighting

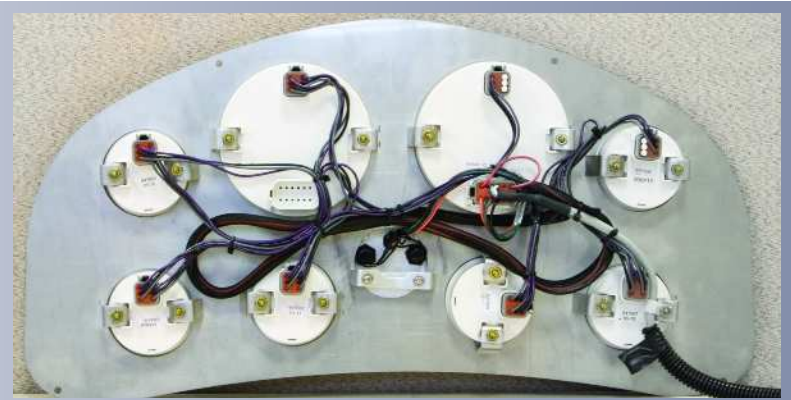

# Visor Rims



Livorsi Visor Rims instantly adds character and dimension to your existing dash. Made of polycarbonate material with a beautiful chrome finish, tough enough to withstand salt water conditions. These rims are made to fit gauges with SAE or low profile rims.

NOTE: Will not work over Mega or Race rims without alterations made by Livorsi Marine, Inc.

- Fits gauges with SAE rim or low profile rims
- Rotate at any angle for the desired look
- Directly attaches to the gauge, screws included
- Corrosion proof PC/ABS construction
- Chrome finish only

Fits gauges with	Part Number
2 1/8" or 2 1/16" cutout	VR218CH
3 3/8" cutout	VR338CH



The visor Rim attaches by slipping the rim from the front of the gauge and slipping the bracket from behind, secure the bracket to the rim with screws and your done.

Flat Bezels			
Fits a...	Cutout	Overall	Part Number
ignition switch	3 /4"	15/16"	FL34 + color
cigarette lighter	7/8"	1 3/8"	FL78 + color
standard gauges	2 1/16"	2 3/4"	FL216 + color
round GPS antenna & recall switch plate	2 1/8"	2 3/4"	FLGPSRS + color
monster gauges	2 5/8"	3 1/4"	FL258 + color
speedo/tach	3 3/8"	4 1/4"	FL338 + color
adapts 3 5/8" or 4" to a 3 3/8" cutout	3 3/8"	4 1/2"	FLGPS + color
liquid speedo	4"	5"	FL400 + color
monster GPS/tach	4 5/8"	5 1/2"	FL458 + color



Flat Bezels

Colors:



Slim Line Bezels			
Fits a...	Cutout	Overall	Part Number
standard gauge	2 1/16"	2 1/2"	FL216S + color
speedo/tach	3 3/8"	3 15/16"	FL338S + color



polish finish

Stainless Steel Flat Bezels			
Fits a...	Cutout	Overall	Part Number
standard gauges	2 1/16"	2 13/16"	FL216SS
monster gauges	2 5/8"	3 3/8"	FL258SS
speedo/tach	3 3/8"	3 3/4"	FL338SS
monster GPS/tach	4 5/8"	5 11/16"	FL458SS



Angled bezels allow for a fish eye view of your gauges, left, right, up or down.



Angled Bezels			
Fits a...	Cutout	Overall	Part Number
standard gauge	2 1/16"	2 3/4"	AG216 + color
monster gauge	2 5/8"	3 1/4"	AG258 + color
speedo/tach	3 3/8"	4 1/4"	AG338 + color
liquid speedo	4"	5"	AG400 + color
monster GPS/tach	4 5/8"	5 1/2"	AG458 + color



# Fuel and Water Level Senders

An electronic sender suitable for gas, diesel and water.

- Constructed to meet/exceed all applicable ISO, NMMA, ABYC and USCG standards
- Standard SAE 5 hole pattern
- Constructed of 316 stainless steel
- Fully insulated to protect against voltage inside the tank
- The float is the only moving part of the sensor minimizing mechanical failure

## How It Works

Measurement is achieved by a series of reed switches positioned inside the level tube. The float with built in magnets then triggers the reed relays generating a potential - free resistance with an ohm value that increases or decreases.



240-33 ohms Sender Length	Part Number
4 inch	SFW4
5 inch	SFW5
5.5 inch	SFW5.5
6 inch	SFW6
7 inch	SFW7
8 inch	SFW8
9 inch	SFW9
10 inch	SFW10
11 inch	SFW11
12 inch	SFW12
13 inch	SFW13

240-33 ohms Sender Length	Part Number
14 inch	SFW14
16 inch	SFW16
18 inch	SFW18
20 inch	SFW20
22 inch	SFW22
24 inch	SFW24
26 inch	SFW26
28 inch	SFW28
30 inch	SFW30
32 inch	SFW32
34 inch	SFW34
36 inch	SFW36

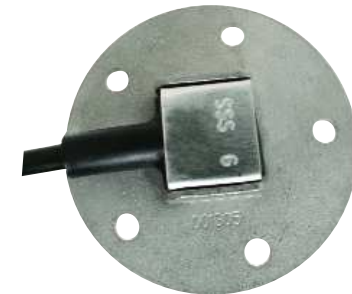

standard 5 bolt pattern

Other resistance outputs, lengths or senders with a 1 ¼" NPT are available upon request.

# NMEA 2000® Harness

Livorsi can supply you with the necessary cables and connectors to expand your NMEA 2000® network. Below is a chart of in-stock parts, for more options please call Livorsi Marine for pricing and availability.

		
single T connector Part Number: 010-11078-00	120 Ohm female terminator Part Number: 010-11081-00	120 Ohm male terminator Part Number: 010-11080-00
		
backbone/drop cable 2 ft Part Number: 000-10068-001	single power cable Part Number: 010-11079-00	MercMonitor page 62
		
backbone/drop cable 6 ft Part Number: 010-11076-00	backbone/drop cable 18 ft Part Number: 010-11076-01	backbone/drop cable 30 ft Part Number: 010-11076-02

# Mercury In Line Gateways

The new Mercury Gateway converts SmartCraft® engine and system data to NMEA 2000® protocol for use on non-Mercury gauges and displays such as our LED Position Indicators.

Note: Gateway will not provide operation power for devices on the NMEA 2000® network.

## Included with Gateway

- Module
- 4 mounting screws
- N2K Tee
- installation instructions



Description	Part Number
single engine gateway	SEGCANP
multi-engine gateway	MEGCANP

Signal	J1939 PGN	Mode
RPM	61444 / 0xF004	TX
Voltage	65271 / 0xFE7F	TX
Coolant Temperature	65262 / 0xFEE4	TX
Fuel Level	65276 / 0xFEFC	TX
Fuel Flow	65266 / 0xFE72	TX
Oil Pressure	65263 / 0xFEEF	TX
Boost Pressure	65270 / 0xFE76	TX
Engine Hours	65253 / 0xFEE5	TX
Manufacturer ID	61182 / 0xEEFE	TX
Alarm Data	65226 / 0xFECA	TX

Signal	NMEA2K PGN	Mode
RPM	127498 / 0x1F20A	RX / TX
Coolant Pressure	127489 / 0x1F201	RX / TX
Speed	128259 / 0x1F503	RX / TX
RPM	127488 / 0x1F200	RX / TX
Voltage	127489 / 0x1F201	RX / TX
Coolant Temperature	127489 / 0x1F201	RX / TX
Fuel Pressure	127489 / 0x1F201	RX / TX
Fuel Level	127505 / 0x1F211	RX / TX
Fuel Tank Size	127505 / 0x1F211	RX / TX
Fuel Flow	127489 / 0x1F201	RX / TX
Oil Pressure	127489 / 0x1F201	RX / TX
Oil Temperature	127489 / 0x1F201	RX / TX
Gear Temp	127493 / 0x1F205	RX / TX
Gear Pressure	127493 / 0x1F205	RX / TX
Boost Pressure	127488 / 0x1F200	RX / TX
Trim Position	127488 / 0x1F200	RX / TX
Rudder Angle	127245 / 0x1F10D	RX / TX
Depth	128267 / 0x1F50B	RX / TX
Depth Offset	128267 / 0x1F50B	RX / TX
Sea Water Temp	130310 / 0x1FD06	RX / TX
Engine hours	127489 / 0x1F201	RX / TX
Manufacturer ID	060928 / 0xEE00	RX / TX
Alarm Data	127489 / 0x1F201	RX / TX
Tabs	130576 / 0x1FE10	RX / TX
Battery	127508 / 0x1F214	RX / TX
ISO Acknowledge	059392 / 0x0E800	RX / TX
Course Over Ground	129026 / 0x9F802	RX / TX
Speed Over Ground	129026 / 0x9F802	RX / TX
GPS Position	129025 / 0x1F801	RX / TX
Address Claim	060928 / 0x0EE00	RX / TX
Product Info	126996 / 0x1F014	RX / TX

# SmartCraft MercMonitor

featuring Mercury® Gateway

MercMonitor featuring the Mercury® Gateway converts SmartCraft® engine and system data to NMEA 2000®/J1939 protocol for use on NMEA 2000®/J1939 multi-function displays and gauges. The ECO-Screen feature constantly monitors engine RPM, boat speed, fuel consumption and engine trim<sup>‡</sup> to automatically calculate and guide you to your best fuel economy settings. No calibration required.



Displays  
NMEA 2000®  
compatible



Gauges  
NMEA 2000®  
compatible



Engines  
NMEA 2000®  
Outboards &  
Sterndrives



Systems  
Trim Tabs &  
Depth Sounders



GPS  
Chartplotters  
Pucks/Receivers

Cutout: 3 3/8"

Overall: 3 3/4"

NMEA 2000® Only Out/In Supported	Data Level
Multiple Tank Levels	2 · 3
Tabs	2 · 3
Depth	2 · 3
Sea Water Temp	2 · 3
Paddle speed	2 · 3
Pitot Speed	2 · 3
Rudder Angle	3
Gear Pressure <sup>6</sup>	3
Gear Temp <sup>6</sup>	3
Fuel Pressure	3

<sup>6</sup> Available on Cummins MerCruiser Diesel Engines  
†† Digital Trim sender required for full functionality.

NMEA 2000®/J1939† Out/In Supported	Data Level
RPM	1 · 2 · 3
Voltage	1 · 2 · 3
Oil Pressure	1 · 2 · 3
Coolant Temperature	1 · 2 · 3
Tank Level Fuel	1 · 2 · 3
Trim Position	1 · 2 · 3
Water Pressure	1 · 2 · 3
GPS Speed/COG/ Lat-Lon (in only)	1 · 2 · 3
Check Engine Alarm	1 · 2 · 3
Fuel Flow	2 · 3
Engine Hours	2 · 3
Boost Pressure <sup>5</sup>	2 · 3
Oil Temperature <sup>5</sup>	2 · 3

<sup>5</sup> Available on Mercury Verado  
† J1939 limits signals and data levels

Merc Monitor Kits		Part Number	Notes:
Data Level 1	Single Engine- Troll Control- NMEA 2000	879337K51	Race Rim sold separately
Data Level 2	Single Engine- RPM SmartTow- NMEA 2000	879338K51	Race Rim included
Data Level 3	Multi Engine- RPM SmartTow- NMEA 2000	879337K52	Race Rim included
Data Level 3	Multi Engine- SmartTow Pro- NMEA 2000	879339K51	Race Rim included
Race Rim for MercMonitor - chrome		MMRRCH	



# Data Gateway (Automotive/Marine)

With the Livorsi Data Gateway you can export CAN (Controller Area Network) engine data to a NMEA 2000® device and display engine data. For use with Vantage View® gauges or a NMEA 2000® navigation device such as Garmin, Lowrance or Raymarine. Please note that engine data is only transmitted if there is a sensor to support it.

Use this gateway to translate information to our state of the art Vantage View® Gauges.

Livorsi's Data Gateway simply plugs into a standard NMEA 2000® Tee connector which can be hooked directly to your device. On the engine side it will interface via CAN+ / CAN- wires to gather the info and send it off to a screen and or gauges.

## Possible Configurations

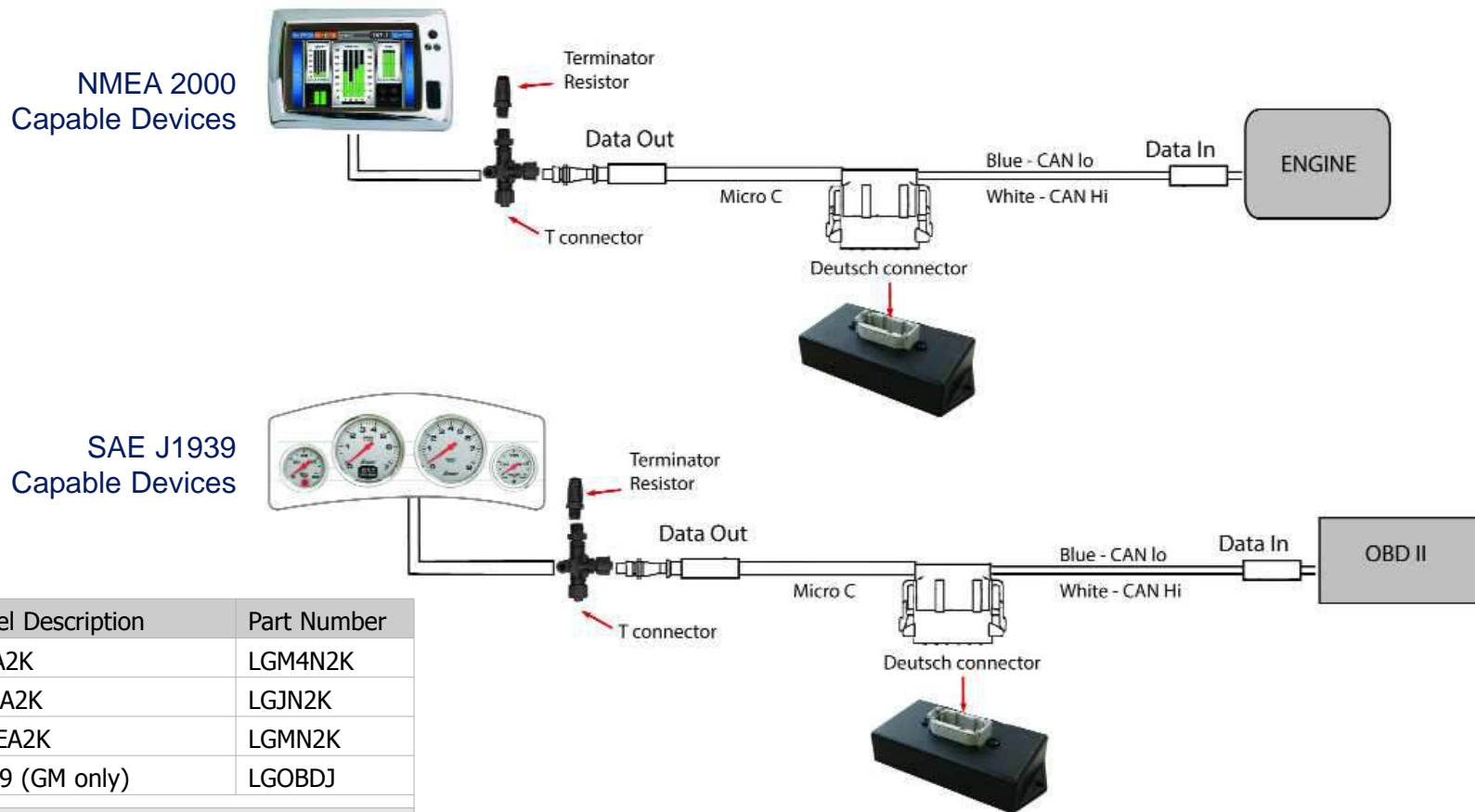

Gateway Model Description	Part Number
MEFI to NMEA2K	LGM4N2K
J1939 to NMEA2K	LGJN2K
MoTeC to NMEA2K	LGMN2K
OBD2 to J1939 (GM only)	LGOBDJ
Harness	
Deutsch/Micro C, 36 inch harness	GATEWH

# Data Gateway (Automotive/Marine)

Your engine application may or may not output all of the parameters listed below. Contact your engine manufacturer for a detailed list.



NMEA backbone cables, T fittings and power cable may be required if you are not tying into an existing backbone.

Please note that a terminating resistor is required for the system to perform as designed.

Please see page 60 for harness accessories.

NMEA 2000 Output Parameters (Tx)				SAE J1939 Output Parameters (Tx)	
Input Parameter(Rx)	MEFI4A	MEFI4B	MEFI5/6 (J1939)	Input Parameter (Rx)	OBDII
Air Temperature	X	X	X	Air Temperature	X
Barometric Pressure	X	X	X	Barometric Pressure	X
Battery Potential	X	X	X	Battery Potential	X
Boost Pressure	X	X	X	Boost Pressure	X
Engine Coolant Temperature	X	X	X	Engine Coolant Temperature	X
Engine Coolant Pressure	X	X	X	Engine Coolant Pressure	
Engine Fuel Rate	X	X	X	Engine Fuel Rate	X
Engine Hourmeter	X	X	X	Engine Hourmeter	
Engine Inlet Air Temp				Engine Inlet Air Temp	X
Engine Percent Load	NA (EEC2) <sup>2</sup>	NA (EEC2) <sup>2</sup>	X1	Engine Percent Load	X
Engine Oil Pressure	X	X	X	Engine Oil Pressure	X
Engine Oil Temperature	X	X	X	Engine Oil Temperature	X
Engine Speed	X	X	X	Engine Speed	X
Engine Percent Torque	NA (EEC2) <sup>2</sup>	NA (EEC2) <sup>2</sup>		Engine Percent Torque	
Fuel Level				Fuel Level	X
Fuel Pressure	NA (EFL/P1) <sup>2</sup>	NA (EFL/P1) <sup>2</sup>	X	Fuel Pressure	X
Run Time Since Start				Run Time Since Start	X
Throttle Position	NA (LFE) <sup>2</sup>	NA (LFE) <sup>2</sup>	X <sup>1</sup>	Throttle Position	X
Vehicle Distance (Since DTC clear)				Vehicle Distance (Since DTC clear)	X
Vessel Speed	X	X	NA (MEFI4B) <sup>2</sup>	Vessel Speed	X
Current Gear				Current Gear	X
<b>Engine Discrete Status:</b>					
Check Engine	X	X			
Rev Limit Exceeded	X	X			
Low Oil Pressure	X				
Low System Voltage	X				
Low Oil Level	X				
General Warning 1	X				
General Warning 2	X				
Low Fuel Pressure	X				
Emergency Stop Mode	X				
Engine Over Temp	X				

# Hydraulic Billet Trim Tabs



## Available with:

- **Custom Logo**
- **LED Underwater Lights** ( 4" or 6" lights in white, blue, red or green)
- **9 Powder Coat Colors**



# Hydraulic Billet Trim Tabs

## Features

- For use on boats 20 - 50 feet
- Mil-Spec hard coat anodized topped with a powder coat finish to prevent corrosion
- Choose between LED electronic position indication (plug and play) or mechanical position indication (uses 33C cables)
- Electronic models are compatible with NMEA 2000® compliant systems and Mercury VesselView®
- The electronic IP68 sensor plugs directly to Livorsi's LED Position Indicator
- Tabs are CNC machined from billet aluminum, no casting
- Bolt patterns include Mercury and a smaller Livorsi bolt pattern for center consoles
- All hinge pins and hardware are stainless steel
- Adjustable transom angles without the use of special tools
- Hydraulic cylinders are designed for 1500 PSI working pressure with dual seals, cylinders may be serviced
- Five anodes for complete saltwater protection
- Available in 11 powder coat colors and private labeling
- Models are available for performance boats, center consoles, cruisers, run-abouts, workboats and military boats



1050 Trim Tab model show here

# Hydraulic Billet Trim Tabs

## Trim Tab Kits include:

- Two billet tabs
- Two pumps
- Mounting hardware
- Harnesses
- Thru hull fittings

Newly designed Parker Pumps  
(Made in the U.S.S.)

Compact design to fit small  
spaces (8.5"W x 1.5" H)

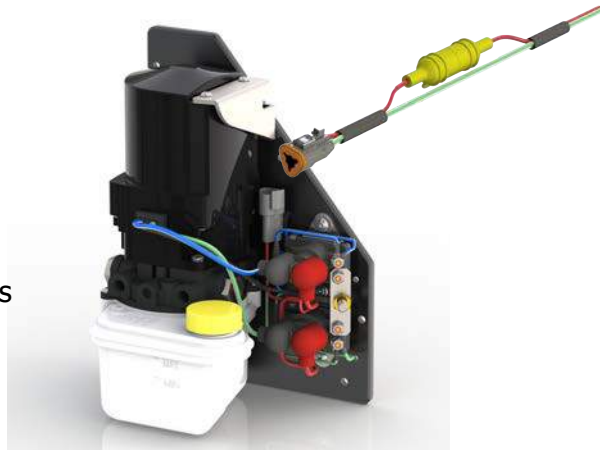

Stainless steel braided hoses are purchased separately. Four hoses are needed for one kit, two per cylinder.

750 Model

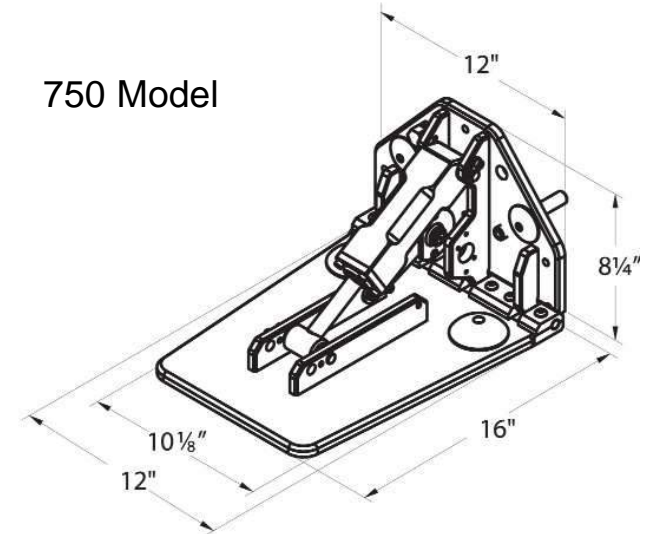

850 Model

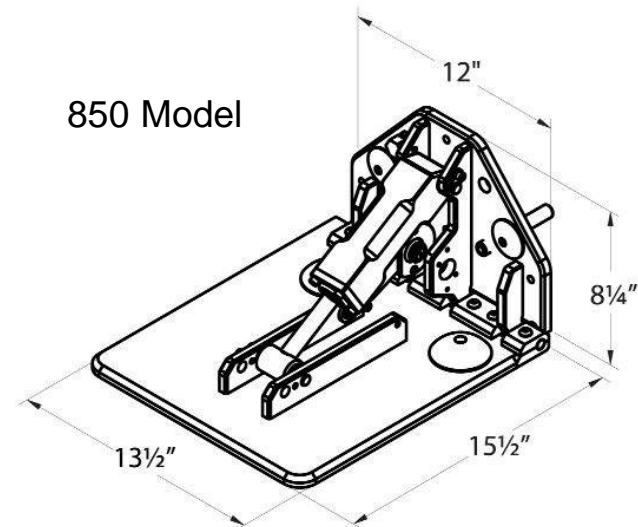

### 750 Performance Kits

TTK750ML	Mechanical cable - Livorsi Transom Plate 16X10"
TTK750MM	Mechanical cable - Merc Transom Plate 16X10"
TTK750EL	Electric Trim - Livorsi Transom Plate 16X10"
TTK750EM	Electric Trim - Livorsi Transom Plate 16X10"

### 850 Military Kits

TTK850ML	Mechanical cable - Livorsi Transom Plate 16X14"
TTK850EL	Electric Trim - Livorsi Transom Plate 16X14"

# Hydraulic Billet Trim Tabs

950 Mercury	<b>(Replacement Kits for 280S)</b>
TTK950ML	Mechanical cable - Livorsi Transom Plate 20X9"
TTK950MM	Mechanical cable - Merc Transom Plate 20X9"
TTK950EL	Electric Trim - Livorsi Transom Plate 20X9"
TTK950EM	Electric Trim - Merc Transom Plate 20X9"

950 Model

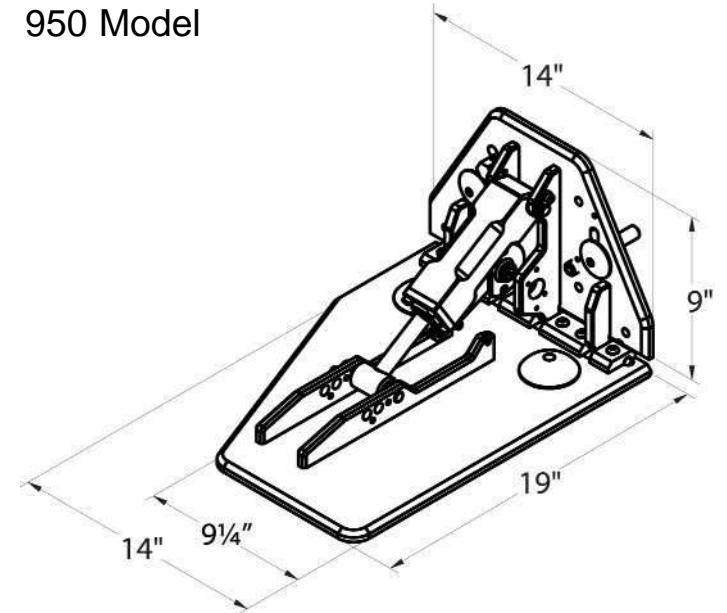

1050 Performance Kits	<b>(Smaller Transom Plate)</b>
TTK1050ML	Mechanical cable - Livorsi Transom Plate 22X10"
TTK1050MM	Mechanical cable - Merc Transom Plate 22X10"
TTK1050EL	Electric Trim - Livorsi Transom Plate 22X10"
TTK1050EM	Electric Trim - Merc Transom Plate 22X10"

1050 Model

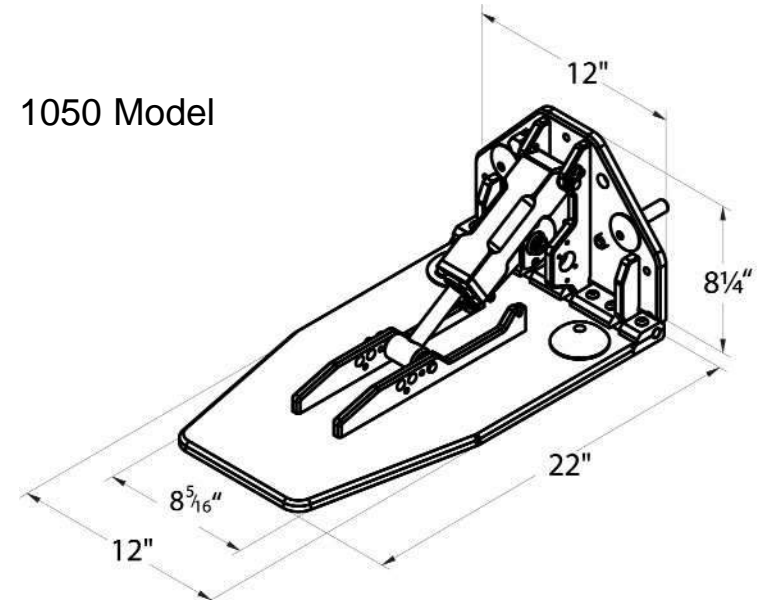

# Hydraulic Billet Trim Tabs

- Electronic models are compatible with NMEA2000® compliant systems and Mercury VesselView®
- The electronic IP68 sensor plugs directly to Livorsi's LED Position Indicator

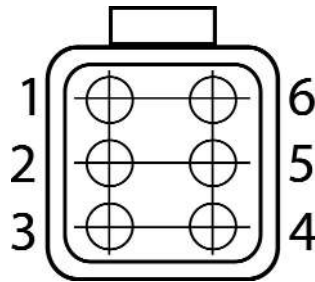

Pin Number	Wire Color	Description
1	Red	PPS1 (5V)
2	White	PPS2 (5V)
3	Blue	PPS1 Signal
4	Black	PPS1 Ground
5	Green	PPS2 Ground
6	Tan	PPS2 Signal



# Hydraulic Pumps

## Pump Assembly Kit 12V Part Number: PAK12V-2

Pump Specifications	
Motor	12 VDC 3-wire reversing continuous ground with thermal breaker
Hydraulic Pump	2 gear drive .0321 CIPR (cubic inches per revolution)
Voltage Rating	12V
Max Pressure Up	1200 PSI
Max Pressure Down	1200 PSI
Solenoid Specifications	
Solenoid type	12V, 65A continuous duty
Special Applications	Marine
Insulated/Ground	Insulated
NO/NC	Normally Open
Circuitry	Single pole, single throw
UL Marine & CE ISO 8846 Marine	N/A
Operating Temperature range	-40° to + 85°C (-40° to + 185°F)
Battery studs	5/16 - 24
Battery stud torque	35 in-lbs max (4.0 Nm)
Contacts	Copper
Coil studs	10 - 32
Coil stud torque	15 in-lbs max (1.7 Nm)

## Pump Assembly Kit 24V Part Number: PAK24V

Pump Specifications	
Motor	24 VDC 3-wire reversing continuous ground with thermal breaker
Hydraulic Pump	2 gear drive .0321 CIPR (cubic inches per revolution)
Voltage Rating	24V
Max Pressure Up	1200 PSI
Max Pressure Down	1200 PSI
Solenoid Specifications	
Solenoid type	24V, 65A continuous duty
Special Applications	Marine
Insulated/Ground	Insulated
NO/NC	Normally Open
Circuitry	Single pole, single throw
UL Marine & CE ISO 8846 Marine	Yes
Operating Temperature range	-40° to + 85°C (-40° to + 185°F)
Battery studs	5/16 - 24
Battery stud torque	35 in-lbs max (4.0 Nm)
Contacts	Copper
Coil studs	10 - 32
Coil stud torque	15 in-lbs max (1.7 Nm)



# Stainless Steel Braided Hoses

Inverted Flare Hose Ends



SAE J514 37° Flare Ends



Inverted Flare Hose Ends	
Length	Part Number
30 inches	SSBH30IN-1
36 inches	SSBH36IN-1
48 inches	SSBH48IN-1
60 inches	SSBH60IN-1
72 inches	SSBH72IN-1
90 inches	SSBH90IN-1
19 feet	SSBH19FT-1
21 feet	SSBH21FT-1
26 feet	SSBH26FT-1

SAE J514 37° Flare Ends	
Length	Part Number
30 inches	SSBH30IN
34 inches	SSBH34IN
60 inches	SSBH60IN
90 inches	SSBH90IN
19 feet	SSBH19FT
21 feet	SSBH21FT
26 feet	SSBH26FT

# Adjustable Position LED Indicators

Displays position for tabs, drives, jackplates, rudder indicator, fuel and water level



Compatible With:

- NMEA 2000® (Rx + Tx) Devices
- J1939 (Rx + Tx) Devices
- Resistive Sensors (ohms)
- SmartCraft® (with Gateway)
- 0-5 Volt Sensors

What sets these displays apart from anything else is the single middle green LED. During calibration, this LED display can be set to indicate 50% of actuator travel, fuel level or whatever you are monitoring.

What makes it so special is that it allows you to establish the optimum running angle - or sweet spot (not at 50%), to dial-in the vessel for optimal running efficiency so the novice boater always runs at the correct trim.

No matter what information you are looking to display (fuel level, drive trim, tab position, etc.), the data is brought into the communication network with plug and play harnessing and is received (Rx) via the network cable to the LED indicator for display.

The LED indicator can also transmit (Tx) this information via CAN bus to other compatible displays such as Garmin, Lowrance or Raymarine via NMEA 2000®, SmartCraft® (with Gateway) or J1939 protocols.

# Adjustable Position LED Indicators



If your boat is already transmitting (Tx) NMEA 2000® data (tabs, drives, fuel level, water level, rudder angle, etc.), simply plug the indicator into the NMEA 2000® backbone to begin displaying the desired feature on the indicator.

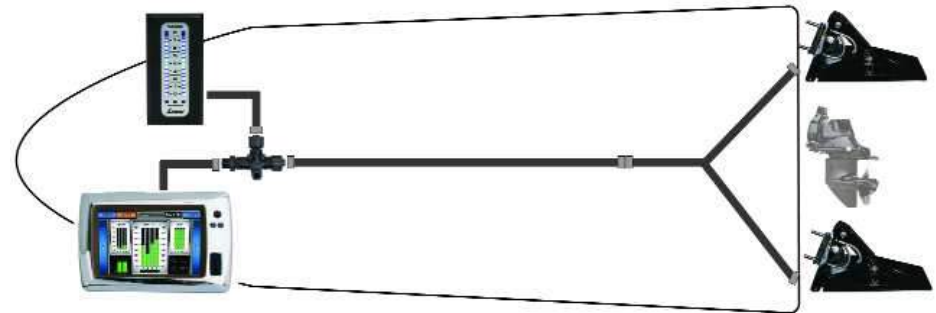

# Adjustable Position LED Indicators

---

- Simple plug and play installation, eliminates clumsy cables
- No cables means, no loss of motion
- All electronics are environmentally sealed
- Has the ability to compensate for non-linear tanks giving you accurate readings
- 0-5 volt or resistive type sensors (adjustable)
- 1 to 4 slot configurations, vertical or horizontal



---

## Dimensions

1 or 2 slot indicator: 2 5/8" W x 5 3/16" H overall  
requires (2) 1-1/4" cutouts for wiring

3 or 4 slot indicator: 4 1/16" W x 5 7/16" H overall  
requires (4) 1-1/4" cutouts for wiring

---

## Power Supply

Input supply voltage of 12 VDC with reverse polarity protection

---

## Calibration

Calibration is performed via the proximity/photo sensor on the front of the indicator

Inputs may be calibrated using either a 2 or 3 point method: minimum / maximum – or minimum / maximum / center running point (green LED)

This indicator has the ability to compensate for non-linear tanks (fuel or water), giving you accurate readings

# Adjustable Position LED Indicators

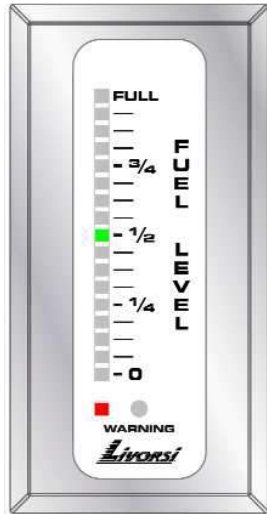

pointer style

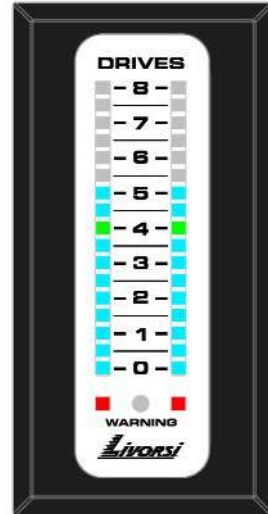

fill bar

## LED Lighting Options Include:

Pointer Style-  
one LED pointer displays your position/level

Fill Bar type-  
multiple LEDs lit in a row, beginning from the top or bottom

The green LED in the center may be calibrated to show optimal level position for Drives, Tabs, etc.

The red LED at the bottom of the indicator can be used as a warning light

Built-in light sensor automatically adjusts to ambient light with 250 brightness intensity levels

## Analog Inputs

Each slot accommodates two analog inputs. One analog input drives the indicator bar, the other drives the optional red warning LED located at the bottom of the slot.

Warnings may include (but are not limited to):  
Oil pressure, water temperature or low fuel with optional switch to close sensor.

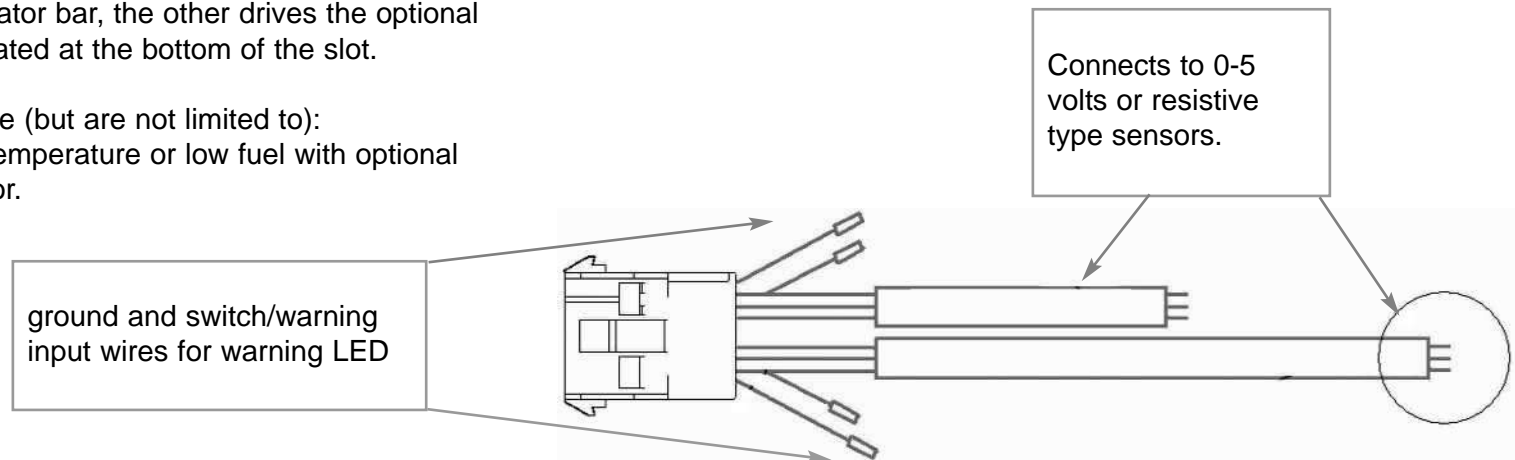

# Adjustable Position LED Indicators

## Dimensions

### 1 & 2 slot

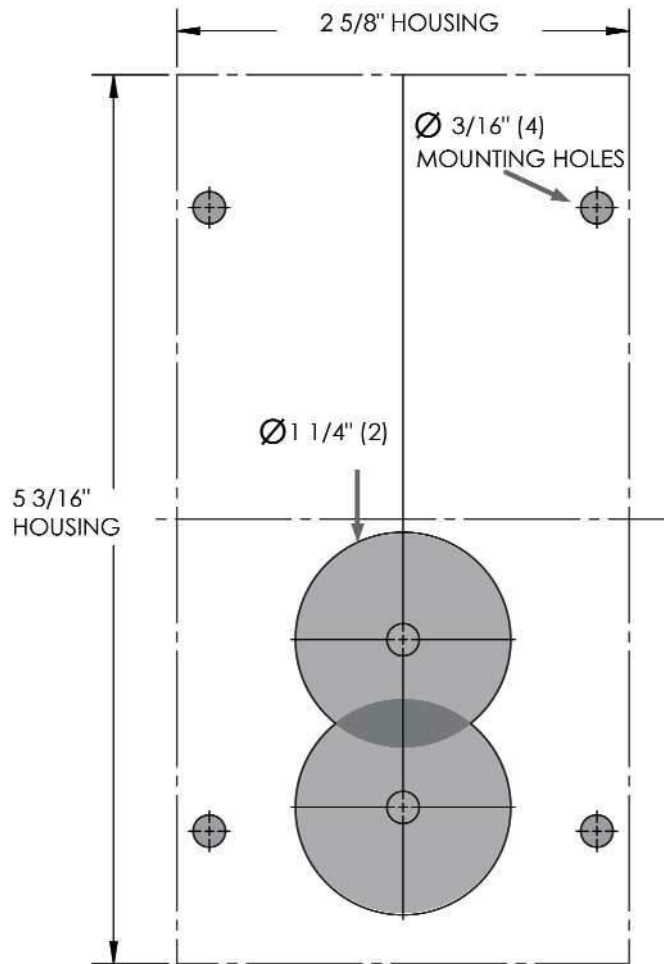

### 3 & 4 slot

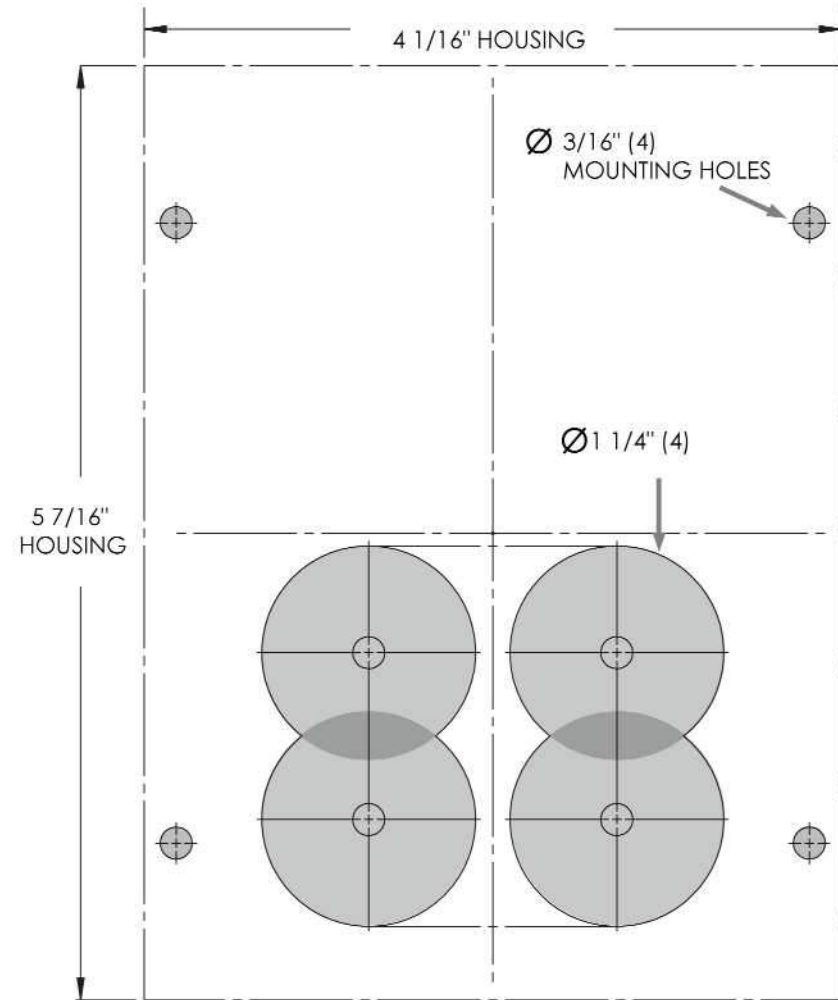

# Adjustable Position LED Indicators

Voltage or Resistance Sensors

Tabs, drives, jack plates, fuel level, water level and rudder indicator applications must have a resistance or voltage type sensor present for this system to operate. Below are some of the options.

Mechanical to Electric Converter 0-5 Volts  
(cable not included)

Converts the mechanical signal to an electric signal. Bolts on the inside of the transom with a short cable to the unit.

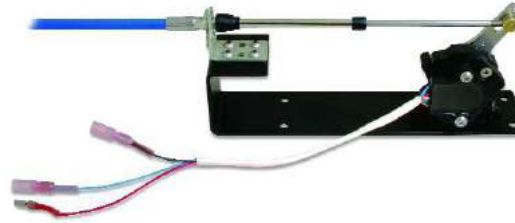

33 Series Cables	
3 ft	CA3
4 ft	CA4
5 ft	CA5
6 ft	CA6

Mounted pot on Mercury trim tab 0-5 Volts

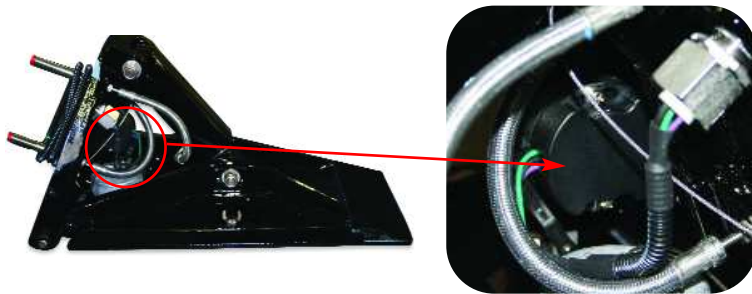

Tabs 2010 or newer should contain the 5 volt sensor  
Tabs 2006-2010 model Number's 280S and 380S should have a bracket to add the sensor

Fuel or water level resistive type sensors 240/33 ohms



NOTE: Must know at time of placing your order, if sensor is a 2 or 3 wire sensor

Retrofitted tabs  
Mercury pot 0-5 Volts

Please contact your nearest Mercury dealer.



Mercury drive pot 0-5 Volts  
Part Number: 863187A1

Please contact your nearest Mercury dealer.



# Adjustable Position LED Indicators

## Building Your Indicator Part Number

NOTE: A 50% restocking fee will be charged for all returned Adjustable Position LED Indicators.

		FIRST ITEM DATA	SECOND ITEM DATA	CARD COLOR	FRAME COLOR	ORIENTATION
		1 or 2 slot	3 or 4 slot			
Part Number Example	ALEDI	2D	2T	PL	CH	V
 <p>ALEDI2D2TPLCH</p>		1 Drive = 1D 2 Drives = 2D  1 Tab = 1T 2 Tabs = 2T  1 Fuel = 1F 2 Fuel = 2F 1 Jack Plate = 1J 2 Jack Plate = 2J 1 Rudder = 1R 2 Rudder = 2R	1 Drive = 1D 2 Drives = 2D 3 Drives = 3D 4 Drives = 4D 1 Tab = 1T 2 Tabs = 2T 3 Tabs = 3T 4 Tabs = 4T 1 Fuel = 1F 2 Fuel = 2F 1 Jack Plate = 1J 2 Jack Plate = 2J	Black = BK Carbon Fiber = CF Platinum = PL Silver Carbon Fiber = SF White = W	Black = BK Blue = BL Chrome = CH Lime = L Mustard = MU Orange = O Platinum = PL Purple = PU Red = R White = W	Vertical = V Horizontal = H

### Vertical Orientation Examples

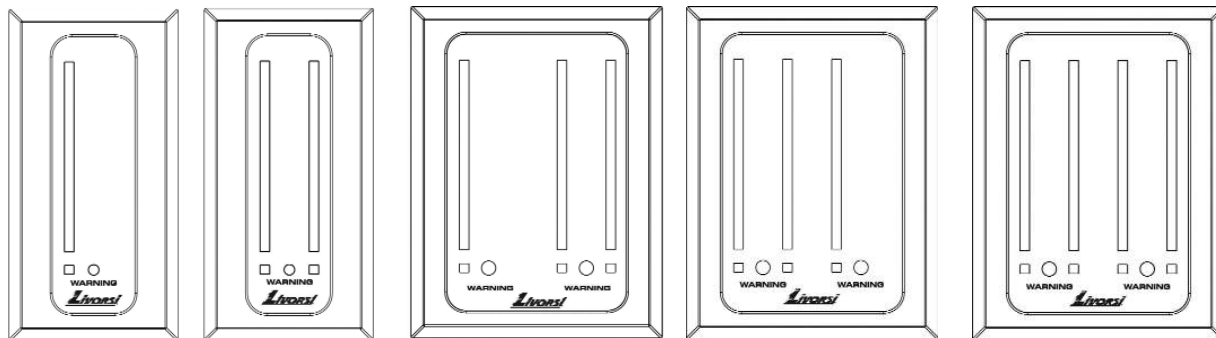

### Horizontal Orientation Examples

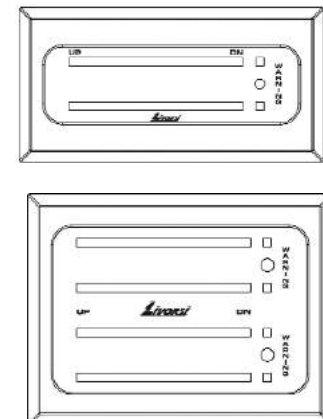



# Adjustable Position LED Indicators

1  
Indicator

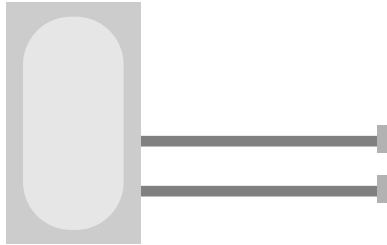

4 slot example:

2  
Main Harness

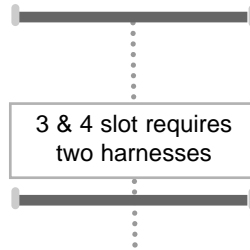

LEDHSA20

3  
Jumper Harness

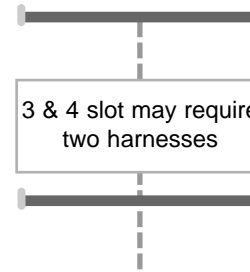

LEDEXT10

Parts To Order

Sensor

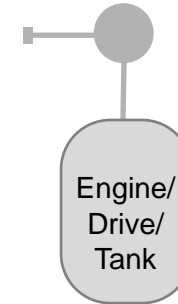

Harness Options		Part Number
	Main Harness to Jumper Harness	
<b>2</b>	a Main Harness 20 feet	LEDHSA20
	b Main Harness 25 feet	LEDHSA25
	c Main Harness 30 feet	LEDHSA30
	d Main Harness 40 feet	LEDHSA40
	Jumper Harness to Sensor Input	
<b>3</b>	a Tab/Drive/Fuel Jumper Single 5 feet	LEDHEXTS
	b Tabs/Drives/Fuel Jumper Dual 10 feet	LEDHEXT10
	c Tabs/Drives/Fuel Jumper Dual 15 feet	LEDHEXT15
	d Mercury SmartCraft® Drive Jumper Single (Y Cable) 5 feet	LEDHYS
	e Mercury SmartCraft® Drive Jumper Dual (Y Cable) 5 feet	LEDHYD5
	f Mercury SmartCraft® Drive Jumper Dual (Y Cable) 10 feet	LEDHYD10
	g Mercury SmartCraft® Drive Jumper Dual (Y Cable) 15 feet	LEDHYD15
	Mechanical to Electric Converter 0-5 Volts	call for part number

# Hatch Actuators

- Safe working load limit of 400lbs.
- Heavy duty sealed ball bearing motor allows for locking of hatches, so it won't open at high speeds
- Marine grade stainless steel housing
- Lifts 2X as fast and has 2X the power of other electric actuators
- Cleaner and more cost-effective alternative to hydraulic and pneumatic models
- Provides consistent performance throughout its lifetime
- 12 VDC



Description	Closed	Open	Part Number
4" throw	10.32"	14.32"	SSA4
8 " throw	14.32"	22.32"	SSA8
12" throw	18.32"	30.32"	SSA12
16" throw	22.32"	38.32"	SSA16
18" throw	24.32"	42.32"	SSA18
24" throw	30.32"	54.32"	SSA24



### Quick Release Pin

- stainless steel & aluminum

Part Number	HAQRP
-------------	-------

aluminum adjustable bracket

Brackets can be sold separately. Washers and bolts not included.

bracket	HAB
adjustable bracket	HABT



stainless steel bracket

### Mounting Kit

Kit includes:

- bracket
- sleeve
- washers & bolts

Part Number	HAMK
-------------	------

# Mechanical Indicators

## Ultra Thin

Livorsi indicators feature a no-slack spring load assist, eliminating slack in the cable giving you a faster indication of your drives and tabs.

- Dash mounted indicator
- Fluorescent red pointers
- Aluminum and composite construction
- Adaptable to any actuator with 3 1/4" throw

### Set Back Kit

- Allows switches to be mounted at cable entry area on your dash



ultra thin  
UMI2D2TBKBK  
horizontal layout, right entry  
standard pointers

Indicators w/ Fluorescent Pointers		Part Numbers
Number of drives	Number of tabs	
1 drive	2 tabs	UMI1D2T + card + frame color
2 drives	2 tabs	UMI2D2T + card + frame color
Specify: direction of cable entry, horizontal or vertical layout		

Ultra Thin face dimensions	
3 or 4 slot	3 3/4" W x 5" H

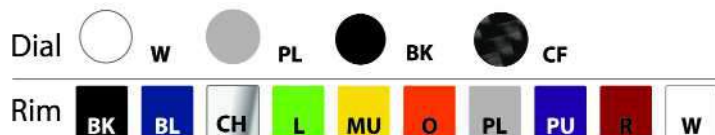

Indicator Parts	
Description	Part Number
<b>Indicator Cards</b>	
3 slot	UIC3 + color
4 slot	UIC4 + color
<b>Frames</b>	
3 or 4	UIF34 + color
<b>Windows</b>	
3, 4 or 5 slot	IW34
<b>Pointer Kit with Springs</b>	
2 slot	IPK2
4 slot	IKP4
<b>Set Back Kit</b>	
2 inches set back	SBK

# Mechanical Indicators

## Standard Size

- Dash mount indicator
- Fluorescent red pointers
- Aluminum and composite construction
- Adaptable to any actuator with 3 1/4" throw

## Set Back Kit

- Allows switches to be mounted at cable entry area on your dash

standard  
MI2DPLBK  
horizontal layout, left entry  
standard pointers

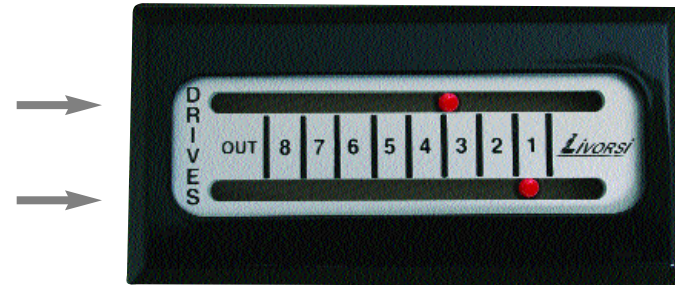

## Indicators w/ Fluorescent Pointers

Number of drives	Number of tabs	Part Number
0 drives	2 tabs	MI2T + card + frame color
1 drives	0 tabs	MI1D + card + frame color
1 drives	2 tabs	MI1D2T + card + frame color
2 drives	0 tabs	MI2D + card + frame color
2 drives	2 tabs	MI2D2T + card + frame color
3 drives	0 tabs	MI3D + card + frame color
3 drives	2 tabs	MI3D2T + card + frame color

Specify:  
direction of cable entry, horizontal or vertical layout

## Standard size dimensions

1 or 2 slot	2 1/2" W x 5" H
3, 4 or 5 slot	5" W x 5" H

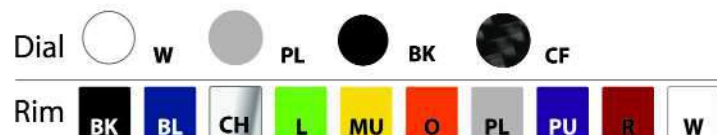

## Indicator Parts

Description	Part Number
<b>Indicator Cards</b>	
1 slot	1SIC + color
2 slot	2SIC + color
3 slot	3SIC + color
4 slot	4SIC + color
5 slot	5SIC + color
<b>Frames</b>	
1 or 2 slot	IF12 + color
3, 4 or 5 slot	IF345 + color
<b>Windows</b>	
1 or 2 slot	IW12
3, 4 or 5 slot	IW345
<b>Pointer Kit with Springs</b>	
2 slot	IPK2
4 slot	IKP4
5 slot	IKP5
<b>Set Back Kit</b>	
2 inches set back	SBK

# Cable Thru Hull Fittings

for 33 C Series Cables

Description	Part Number
stainless steel 90°	THF
stainless steel 45°	THA
solid billet stainless steel 90°	THFB
solid billet stainless steel 45°	THAB

THF



THFB

THA



THAB



## Momo Budelli - MBSWP

- Leather like grips
- Polished spokes



- 13.5" diameter
- 6 bolt pattern
- 10-32 thread pitch

Kit Includes:

- 2 1/4" black hub
- Center cap
- Mounting screws

## Momo Linosa - MLSW

- Brushed spokes
- Chrome accents



# Gussi Steering Wheels

- polished aluminum spokes with tear drop design
- black urethane grips
- diameter: 13.5"
- available in blue, red, yellow and silver
- fits 3/4" rounded shaft with keys



## Part Number: GWSSFK

- stainless steel polish finish
- stainless steel spokes with tear drop design
- Stainless steel speed knob
- diameter: 13.5 "
- fits 3/4" rounded shaft with keys



blue wheel	GWASBL
silver wheel	GWASS
yellow wheel	GWASY
red wheel	GWASR



# Gussi Steering Wheels

## Part Number: GWSSK

- stainless steel polish finish
- stainless steel spokes with tear drop design
- Stainless steel speed knob with leather like accent
- diameter: 13.5 "
- fits ¾" rounded shaft with keys



## Part Number: GWBAS

- anodized aluminum spokes
- black anodized hub
- black urethane grips
- diameter: 13.5"
- fits ¾" rounded shaft with keys





# Gussi Steering Wheels

---



GWSSFL

- solid cast stainless steel spokes
- wrapped with black marine leather or marine carbon fiber urethane
- stainless steel center pad
- diameter: 13.5"
- fits 3/4" rounded shaft with keys



GWSSBKL



# Isotta Steering Wheels



## Isotta Carlotta

- 6 bolt pattern
- 10-32 thread pitch
- 13.5" diameter
- Black wheel is wrapped in genuine leather

### Kit Includes:

- Hub
- Center cap
- Mounting screws



black	ISWKCBK
silver	ISWKCSF

# Isotta Steering Wheels

## Isotta Aria **(DISCONTINUED)**

- 6 bolt pattern
- 10-32 thread pitch
- 13.5" diameter

### Kit Includes:

- Hub
- Center cap
- Mounting screws



blue	ISWKABL
red	ISWKAR
silver	ISWKAS

# Isotta Steering Wheels

## Carbon Fiber **(DISCONTINUED)**



Part Number: ISWK13CFBK

- brushed spokes
- carbon fiber pattern
- leather-like grips and center cap
- diameter: 13.5"



# Hub Adapter

- For use with Isotta or Momo steering wheels
- 3" deep
- powder coat finish

Part Number	HA + color
-------------	------------

Colors:



# Cleats

## Mushroom Cleat

- Secure your fender lines to these mushroom cleats
- For fresh water or salt water conditions
- Easy installation, requires 3/4" cutout, 2" overall
- Stainless steel with a polished finish

Description	Part Number
mushroom cleat	MC



## Quick Release Fender Cleat

- Quick release pin for fenders
- Not intended for mooring
- Made of 316 stainless steel
- 1.43" base

Description	Part Number
fender cleat	QPC

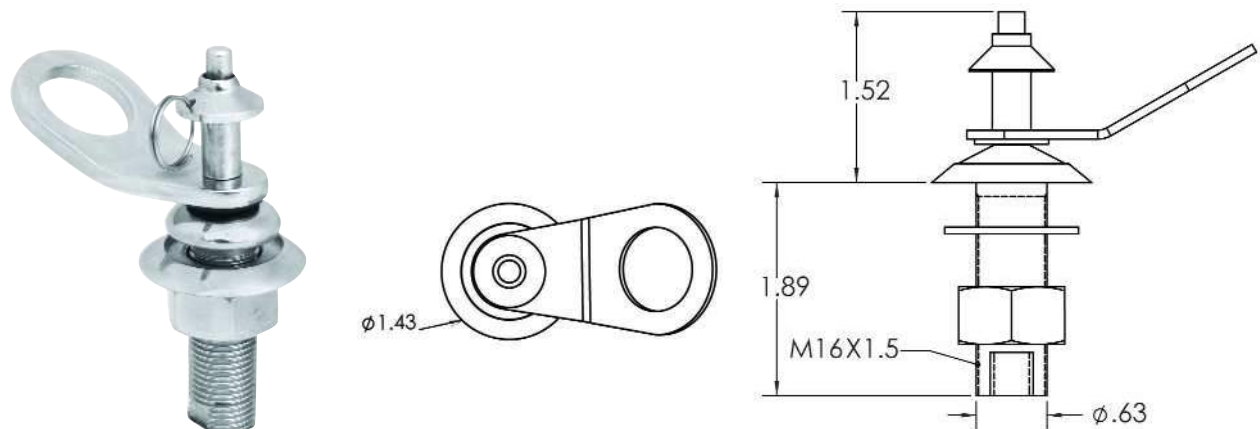

# Pull Up Cleats / Fender and Dock Lines

- Oversized loops
- Made of water resistant polypropylene
- Will not mildew
- Extremely flexible and resists knotting

- Sleek design is easy to install and eliminates the need for drainage cups and hoses
- Mounded base design allows water to run off the cleat
- Made of marine grade 316 stainless steel for strength
- Polished finish for a long lasting shine

Description		Part Number
Fender Lines 1/2" thick	7 feet long	FL127 + color
Dock Lines		
1/2" thick	15 feet long	DL1215 + color
1/2" thick	20 feet long	DL1220 + color
5/8" thick	25 feet long	DL5825 + color
5/8" thick	30 feet long	DL5830 + color

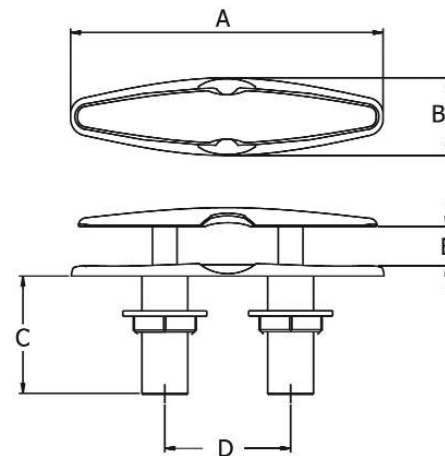

Part Number	PUC4	PUC6	PUC8
Weight	.8 lbs	1.2 lbs	2.56 lbs
A - Length	4.5"	6"	8"
B - Width	1.15"	1.5"	2"
C - Depth	2"	2.3"	3.1"
D - Clearance	.75"	1"	1.25"
E - Leg Distance	1.8"	2.4"	3.2"
Hole Size	3/4"	7/8"	1"
Max Line Size	1/2" diam.	3/4" diam.	1" diam.
Thread Size	3/4 - 16	7/8 - 14	1 1/2 - 14

# Switches



## Black & White Rocker Switches

- dust & moisture protected
- snap bracket mounting hole
- 20 amps at 12 VDC
- 1/4" push-on connectors
- 83" x 1.450" cutout
- available in black (BK) or white (W)

Single Pole- Lighted	
on/off	RSSNFL + color
on/off/on	RSSNFNL + color
Single Pole- Non Lighted	
mom on/off	RSSMF + color
mom on/off/mom on	RSSMFM + color

Double Pole	
on/on- non lighted white	RSDNNW + color
on/off- lighted	RSDNFL + color
on/off/on- lighted	RSDNFNL + color
mom on/off/mom on -non lighted	RSDMFM + color

Switch Covers Only	
no light	SCNL + color
1 light	SC1L + color
2 lights	SC2L + color
Cover Removal Tool	SCRTL



## Mounting Modules

for Black & White Rocker Switches

- snap together
- available in black only

Mounting Modules	
end	EMM
center	CMM
plug	MMP



## Military Rocker Switches

- military type specs
- environmentally sealed
- 5 amps at 28 VDC
- .94" X 1.51" cutout

single pole	
mom on/off/mom on	MRSSMFM + color
double pole	
mom on/off/mom on	MRSDMFM + color
military cover only	MC + color
covers available: red, white or translucent	



## Military Toggle Switches

- military type specs
- environmentally sealed
- 15 amps at 28 VDC
- 1/2" cutout
- screw terminals
- lift / lock lever

Single Pole	
on/off	MTSSNF
on/off/on	MTSSNFN
mom on/off	MTSSMF
Double Pole	
on/off	MTSDNF

MCR



MCW

MCTR

## Toggle Switches

- nickel plated brass
- 1/2" cutout
- 25 amps at 12 VDC
- optional colored rubber boots



Description	Part Number
on/off	TSNF
on/off/on	TSNFN
mom on/off	TSMF
mom on/off/mom on	TSMFM

rubber boot	TSRB + color
-------------	--------------

boots available in: yellow, white, blue, purple, red, orange or black

## Toggle Switch Cover

red only	TSC
----------	-----



## Circuit Breaker Toggle Switches

- requires 1/2" cutout



Description	Part Number
5 amp	TBS5
10 amp	TBS10
15 amp	TBS15
20 amp	TBS20
30 amp	TBS30
<b>Boots</b>	
boot- white	TBSBBK
boot- black	TBSBW

## Push Button Circuit Breaker

- 3/8" cutout
- clear boot sold separately



Description	Part Number
10 amp	PBCB10
15 amp	PBCB15
20 amp	PBCB20
boot only	PBBCL



# Xtreme Nut & Boot System



for Push Button  
Circuit Breakers

- 3/8" threaded neck
- sold by the pack

pack includes:  
- 6 clear boots, 6 nuts,  
seals & wrench

XCBNB + color



for Circuit Breaker  
Toggle Switches

- 1/2-32" threaded neck
- sold by the pack

pack includes:  
- 6 black boots, 6 white  
boots, 6 nuts, seals &  
wrench

XCBTSNB + color



for Toggle Switches

- 15/32" threaded neck
- sold by the pack

pack includes:  
- 6 black boots, 6 white  
boots, 6 nuts, seals &  
wrench

XTNB + color

# Underwater LED Lighting

These rugged lights beautifully light up the water around you creating a stunning aura; they have even been known to attract sea life. For use on boats and docks.

LED's are designed to have a long life span and these provide over 40,000 hours of light. Built with internal self protection circuitry, these lights will not burn you or your gel coat. This product uses water to cool, but are engineered to and tested to run continuously and safely out of the water. Lights will automatically turn off when it reaches its max temperature and then automatically turn back on after it cools.



## LED Features:

- High intensity LED lighting
- Surface mount - no major hull penetration
- Fully Submersible - water cooling required
- 316 stainless steel with polycarbonate lenses
- Long life- LED lamp life over 40000 hours
  
- Operating voltage 9 to 30 volts DC - brightness does not change
- Standard wire length - 20 feet
- Internal digital switching power supply
- Self contained, no external driver to install
- Rugged design
  
- Low power consumption
- Internal surge suppression
- Internal temperature protection

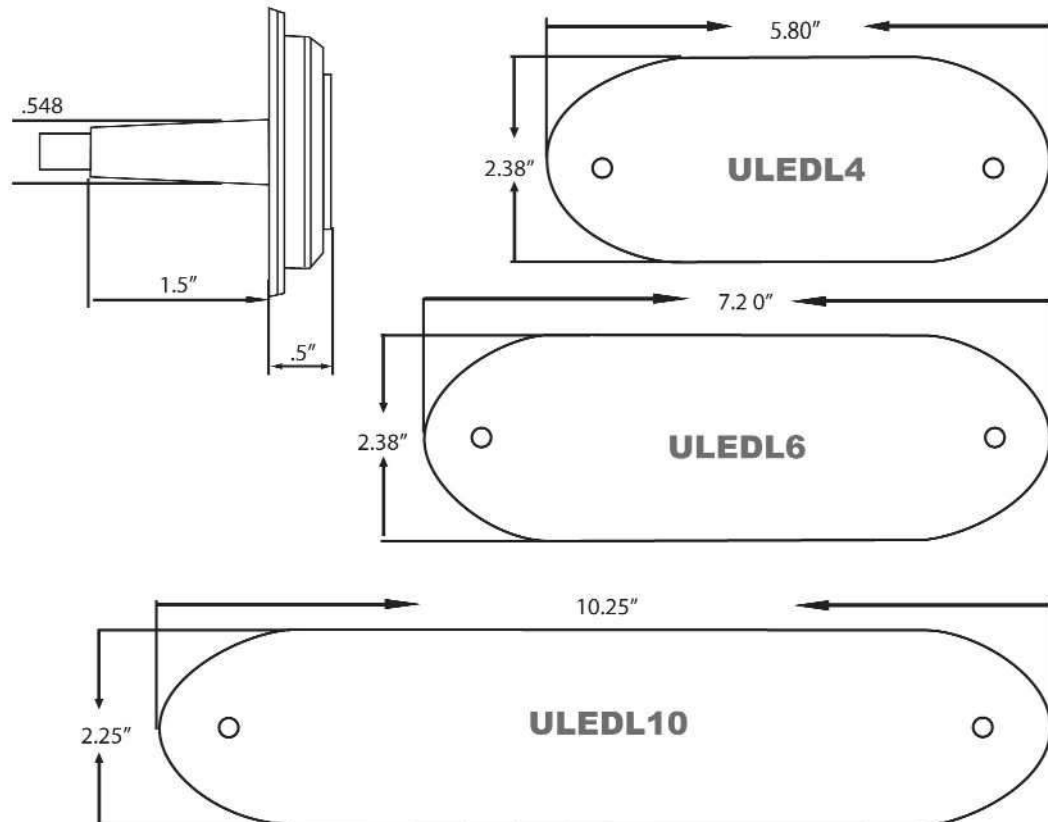

# Underwater LED Lighting

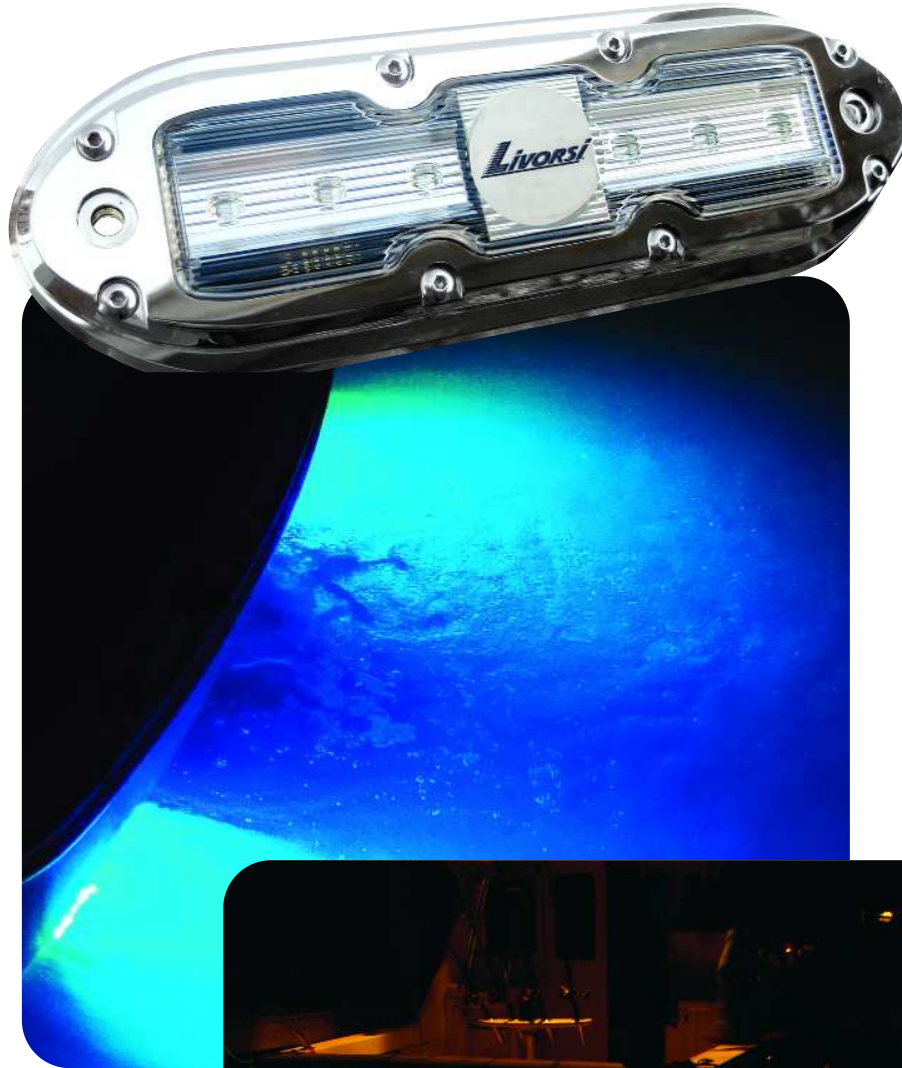

**W**

**BL**

**R**

**UB**

**G**

Number of LED Lights	4	6	10
LED Color			
white	ULEDL4W	ULEDL6W	ULEDL10W
blue	ULEDL4BL	ULEDL6BL	ULEDL10BL
red	ULEDL4R	ULEDL6R	ULEDL10R
ultra blue	ULEDL4UB	ULEDL6UB	ULEDL10UB
green	ULEDL4G	ULEDL6G	ULEDL10G

Number of LED Lights	4	6	10
Specifications			
Watts	17	25	42
Amps	@12v:1.4	@12v:2.1	@ 12v:3.5
Height	2.375"	2.375"	2.25"
Width	5.8"	7.2"	10.25"
Deep	2"	2"	2"
Lumen Output White only	1000	1500	2500





shown closed  
with optional cup

## Pop Up LED Bow Light

- Port and starboard light in one housing
- Marine grade 316 stainless steel
- Folds down flush when closed
- USCG approved for 2 nautical miles
- LED lights stay cool to the touch
- Optional cup for water run-off
- Light with cup measures 3 1/4" deep
- Light has 3 1/2" diameter cutout

Description	Part Number
bow light	LEDPUBL
water run off cup	LEDPUBLWC

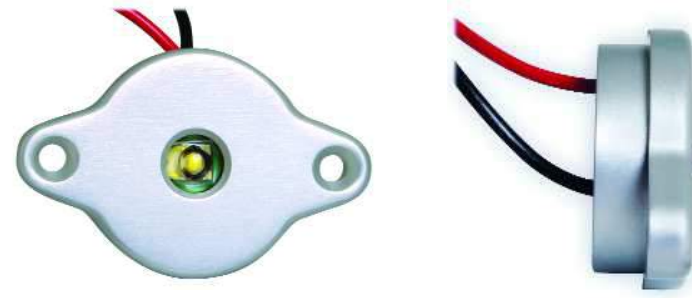
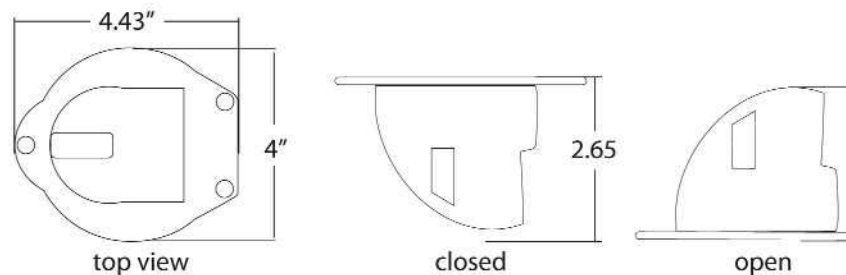

## Flange Mount LED Lighting

- Not certified for use as navigation lights
- Housing is machined from billet aluminum
- Environmentally sealed
- Bright LED can illuminate engine compartments

Description	Part Number
red	LEDR
green	LEDG
white	LEDW

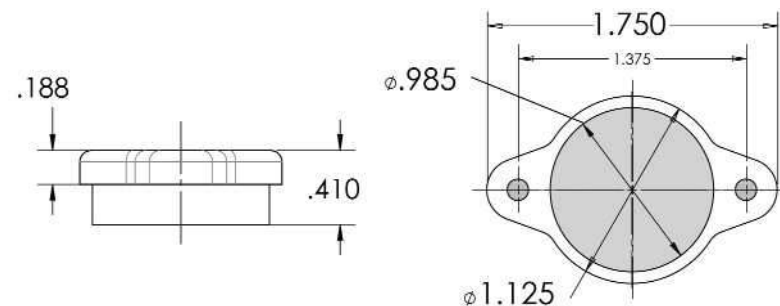

# LED Navigation Lights

These Livorsi LED nav lights only consume 1/10th of an amp at 14 volts. This means a longer life and less rigging time replacing lights. These lights are to be used on any vessel up to 65 feet and have a visibility of 2 nautical miles.

Designed to be mounted on a vertical surface, to allow the light pattern to be unobstructed from view.

- Visible for 2 nautical miles
- For use on boats up to 65 feet
- Marine grade 316 stainless steel
- Available for 12 or 24 volt systems
- Completely waterproof, environmentally sealed
- NMMA accepted
- USCG approved for 2 nautical miles
- Meets ABYC standards

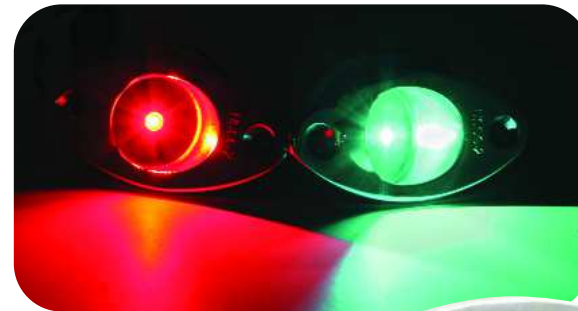

Description	Part Number
port - red	LEDNL2R
starboard - green	LEDNL2G
adapter plate	LEDNLAP



LEDNLAP  
8" L x 2 1/4" W x 1/16" thick

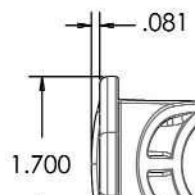
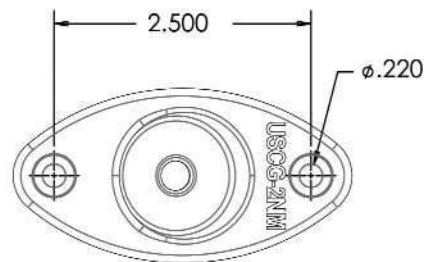
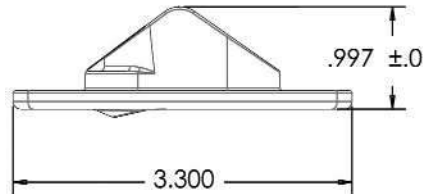

ABYC Section A-16: The starboard sidelight showing green, and the port sidelight showing red, from dead ahead to 22.5° abaft the beam (90° + 22.5° + 112.5°) on their respective sides.

Mounting angle for navigation lights is 24° relative to centerline of boat.

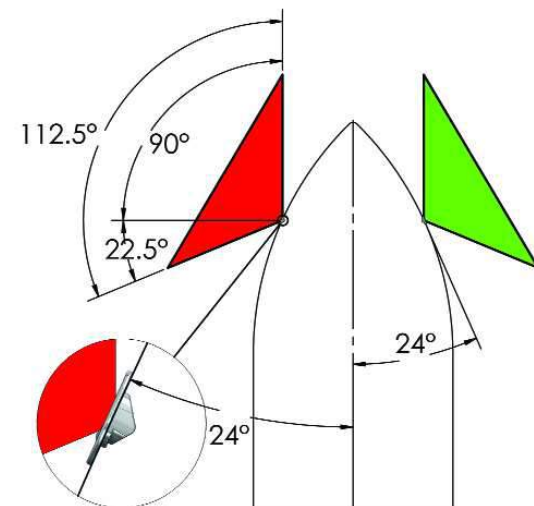

# CMI's Sound Elimination Mufflers

High Performance

CMI Sound Elimination Systems mufflers offer proven sound reduction technology that enables boaters to operate their performance boats in areas where sound emissions are restricted. This system should reduce sound emissions to levels as low as 85 decibels (dB) in many applications, which is below most sound emission regulations. The mufflers are engineered to reduce sound without restricting the exhaust or creating unwanted backpressure, which can inhibit the engine from reaching peak performance power.

- Mufflers can be installed on any exhaust system with tailpipes ranging from four to six-inches in diameter, which covers the full range of inboard or stern drive-powered recreational and performance boat applications up to 1200 horse power.
- CMI Sound Elimination Systems mufflers are made from 304 series stainless steel, and have fewer moving parts than competitive models to ensure long-lasting durability and reliability for nearly any application.

Clamp-On



## Clamp On High Performance

Figure	Description	Part Number
A	4" x 5" under 600 HP	SEMSCHP4
B	4.5" x 5" under 600 HP	SEMSCHP4.5
C	4" X 6" over 600 HP	SEMSCHP4X6
D	4.5" X 6" over 600 HP	SEMSCHP4.5X6
E	5" X 6" all HP	SEMSCHP5X6

## Transom Mount High Performance

Figure	Description	Part Number
F	4" under 600 HP	SEMSTHP4

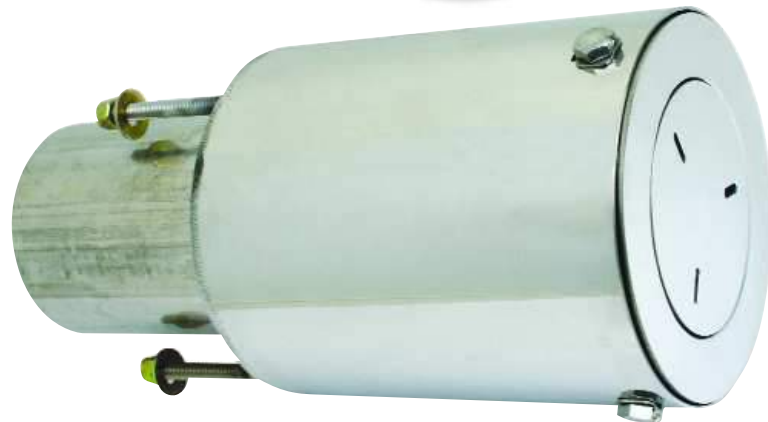

Transom Mount

See diagrams on the back of this page to find the right muffler for your application.

# CMI's Sound Elimination Mufflers

High Performance

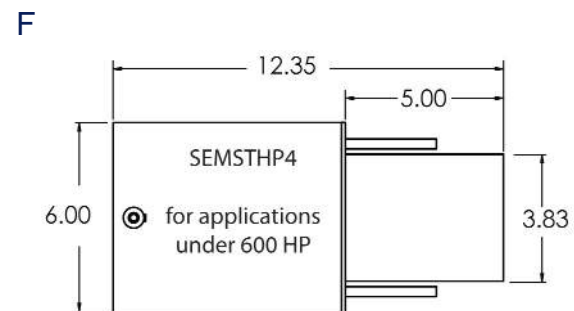
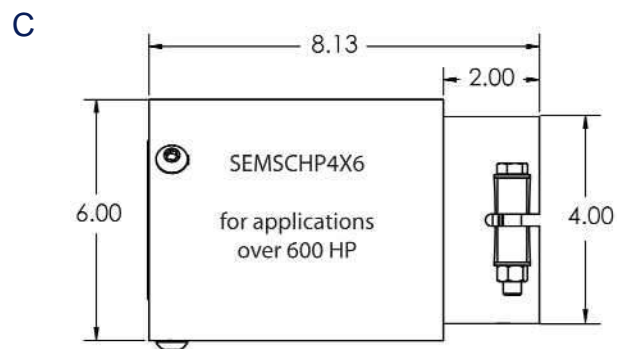
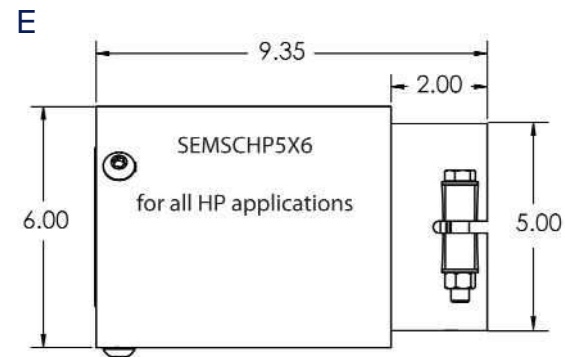
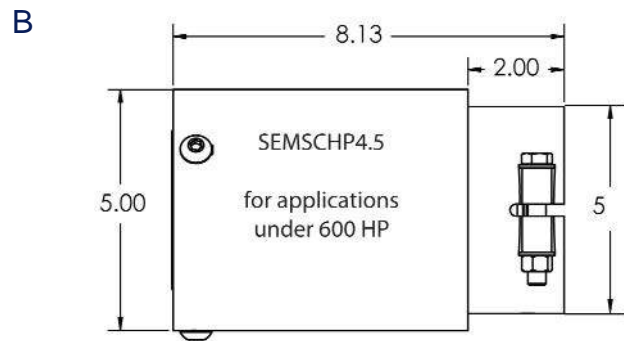
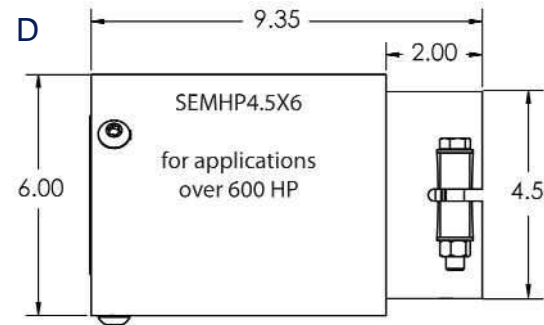
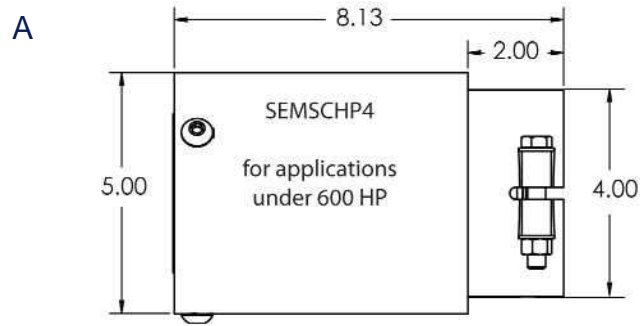



## Ultimate Bravo Drive Shower

- Mounts to the drive's tilt ram
- 15 dump ports target sides & back of the drive
- Multiport system distributes continuous cool water
- Flow to top of the stern drive
- Lowers oil & bearing temperatures by 60°
- Fits all Bravo drives including: Imco & Latham steering that mounts on back of the drive

Part Number	BDSU
-------------	------



## Bravo Drive Cooling Shower

- Modern sleek fitted shower
- Coupled with a high volume pickup
- #10 stainless steel braided hose

Fits the following Drives	
X1, X2, X3	
XR/XZ	
XZ1	XZ1 w/ Intergrated top
XR	XR w/ Intergrated top
XR3	XR3 w/ Intergrated top
XR Sportmaster	XR Sportmaster w/ intergrated top

Description	Part Number	
Cap / Hardware	Fits Drive Serial Number	
ribbed- bolts	OW250000 & up	BDSX
	OW240000 & up	
	OM906878 & up	
ribbed- studs	OW240000 & up	BDSXR
	OM05295-OM906877	
	OM906878 & up	



# Sea Strainers

## SS Sea Strainer

- Stainless steel construction
- Two bungs measure 1"
- One bung measures 1/2"
- Pressure tested at 150 PSI
- 1" NPT fittings
- 60 GPM flow at 22 PSI
- High impact 1" acrylic lid
- Removable stainless steel basket with easy lift handle
- Optional floor mount brackets & fittings available

Description	Part Number
same side bungs	SS5SS
straight through bungs	SS5ST

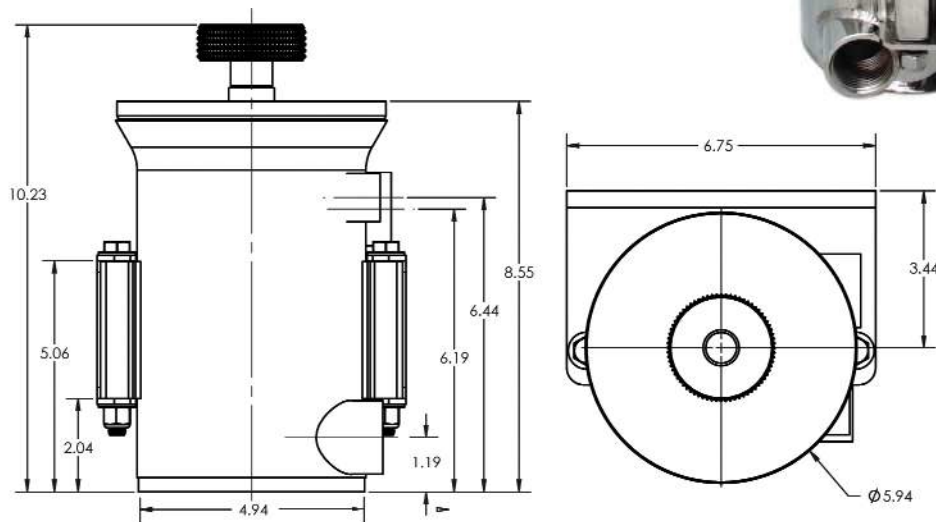

GSSFS



GSSF90



GSSF45



SSFMB

Description	Part Number
straight fitting	GSSFS
90° slip on fitting	GSSF90
45° fitting	GSSF45
floor mount brackets	SSFMB

# Optima Battery Boxes



## Anodized Battery Box

- Machined from billet aluminum
- Black anodized finish is non-corrosive
- Box cover has a slip resistant surface
- Can be stringer mounted
- Measures: 11 15/16 in. L x 8 in. W x 6 5/8 in. H

Description	Part Number
box and cover - black only	BBBO34A

### Colors:



## Powder Coat Finish

- Machined from billet aluminum
- Corrosive resistand polish or powder coated finish
- Optional cover available
- Can be stringer mounted
- 11-15/16" L x 8" W x 6 5/8" H
- Private Label available on cover

Description	Part Number
box	BBBO + color
cover	BBBCO + color



# Fire Extinguisher and Mounting Hardware

## Bar Mount

- Machined of billet aluminum
- Fits 1 1/2", 1 3/4" and 2" tubing
- Black powder coat finish only
- Quick release pin



## Flat Mount

- Machined of billet aluminum
- Available in powder coat colors or a clear coat
- Quick release pin



## Fire Extinguisher

- Encased in marine approved chrome
- Dry ABC extinguisher
- 2 1/2 lbs, refillable
- Extinguisher and mounts are sold separately



Description	Part Number
fire extinguisher	FE
bar mount	FEBMKBK
flat mount	FEMBK

# Grab Handles

## Colors:



Steel	
11 3/4" overall (10 1/2" center to center)	GHSS11 + color



Aluminum	
6 15/16" overall	GHAS7 + color
11 7/16" overall	GHAS12 + color

# Beverage Holders

## Stainless Steel Beverage Holders

- Fits cans, bottles and kuzis
- 304 stainless steel
- Optional fittings available
- Polish stainless steel or powder coat finish

Description	Cutout	Overall	Part Number
<b>Stainless Steel Finish</b>			
small stainless	3 5/8"	4 1/8"	SBHS
large stainless	3 3/4"	4 1/2"	SBHL
<b>Powder Coat Finish</b>			
small	3 5/8"	4 1/8"	SBHS + color
large	3 3/4"	4 1/2"	SBHL+ color
<b>Drain Fittings for</b>			
3/8" straight push on			SBHFS3/8
3 /8" 90° push on			SBHF903/8
drain cap			SBHC



## LED Lighted Beverage Holders

- 3 7/8" cutout, 4 3/4" overall
- Fits cans, bottles and kuzis
- 12 volt, included 12 inch harness
- Black cup, stainless steel rim
- 3/8" drain fitting
- Removable rubber

Description	Part Number
blue	LBHBL
green	LBHG
red	LBHR