

Installation guide

Thank you for purchasing a Lopolight product. Our products are built to ensure a long lifetime in the most extreme marine conditions.

Mounting:

For directional lights the alignment to the vessel centerline is very important.

Horizontally mounted lights are opened/closed as illustrated, please ensure lock screw engages correctly.

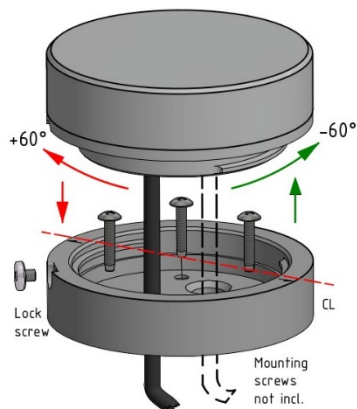

Connecting power:

Supply Voltage: Any DC voltage between 10 and 32 volts. (12 and 24 Volt systems)

Cabled lights:

Red wire: Positive (+) Black wire: Negative (-).
(Double light: 2 cables, same colour coding)



Light with green connector: Single light:

Pin 1: Positive (+) Pin 2: Negative (-) (pin 3-5: not used)

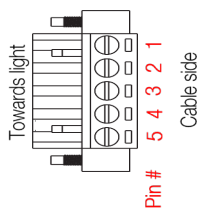

Double light:

Primary light: Pin 1: Positive (+) Pin 2: Negative (-)

Secondary light: Pin 4: Positive (+) Pin 5: Negative (-)
(pin 3 not used)

Recommended fuse or circuit breaker: Less than 2A (slow).

Grounding: The navigation light housing should not be connected to ground (Earth).
(We recommend that you connect the cable screen to ground (Earth)).

Cabling: Avoid chafe and route it away from sources of heat and large inductive fields such as electric motors.

Cleaning your product:

- Wipe off your product with a normal detergent, on a damp cloth
DO NOT use alcohol or thinner for cleaning your light – this could damage the lens.

Troubleshooting:

If the light does not function:

- Check that you have a supply Voltage between 10 and 32 Volt DC.
- Check that the polarity is right (you will not damage the Lopolight by accidentally wiring the polarity wrong).

End of life signaling:

Your Lopolight product has a microprocessor inside that ensures that the light has required intensity over a 50.000-hour projected lifetime. The light will signal to you when it is getting to the end of its useful life. The following signals can be observed:

- **All OK:** 5 seconds after turning on the light it will go dark for 0,1 second and turn on again. This is just a check for you to assure that the microprocessor is working.
- **Less than 2000 working hours left:** The dark period is extended to 2 seconds: you should change the light at your next service within the next 12 months.
- **Light Expired:** The dark period is extended to 5 seconds: You should change the light immediately. (The light will still be working, even in the expired state)

Approvals:

The light in this package is type approved to the following standards:

- EN-14744, UL-1104, COLREG72, IEC 60945

Recognized by the following authorities:

- IMO, MED (EU-wheelmark), USCG