

LOWRANCE®

ActiveTarget™

INSTALLATION MANUAL



1

Parts included

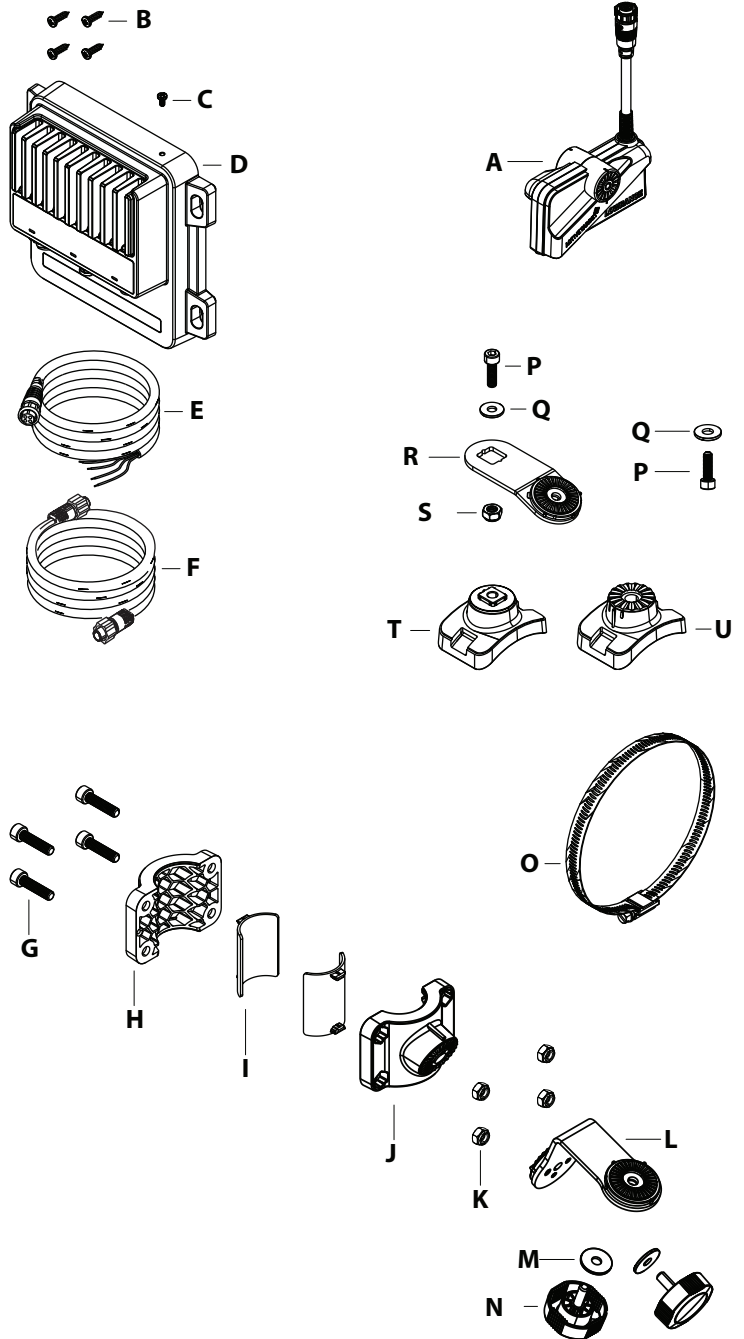

- A** ActiveTarget transducer
- B** Sonar module mounting screws
- C** M4 sonar module grounding screw
- D** Sonar module
- E** Ethernet cable
- F** Power cable
- G** M6x20 cap screw, 4x
- H** Trolling motor shaft collar back (shaft mount)
- I** Rubber collar inserts, 2x
- J** Trolling motor shaft collar front (shaft mount)
- K** M6 nut, 4x
- L** Trolling motor bracket arm (shaft mount)
- M** M6 metal washers, 2x
- N** Transducer arm knobs, 2x
- O** Hose clamp
- P** M6x20 cap screw, 2x
- Q** M6 metal washer, 2x
- R** Trolling motor scout arm (motor mount)
- S** M6 nut
- T** Trolling motor scout mounting bracket (motor mount)
- U** Trolling motor down/forward mounting bracket (motor mount)

2

Sonar module installation

This chapter describes how to install the sonar module.

Mounting guidelines

Choose the mounting location carefully, make sure that there are no hidden electrical wires or other parts behind the panel before you drill or cut. Ensure that any cutting or drilling is done in a safe position and will not weaken the boat's structure. If in doubt, consult a qualified boat builder, or marine electronics installer.

Do not:

- Mount any part where it can be used as a hand hold.
- Mount any part where it might be submerged or exposed to moisture.
- Mount any part where it will interfere with the operation, launching, or retrieving of the boat.
- Mount in a way so that moisture or condensation water can follow the cables into the device.

Do:

- Consider the overall width and height requirements.
- Leave sufficient clearance to connect all relevant cables.
- Check that it is possible to route cables to the intended mounting location.

→ **Note:** The enclosure should be dry and well ventilated. In small enclosures, it may be required to fit forced cooling.

! Warning: Inadequate ventilation and subsequent overheating of the equipment may cause unreliable operation and reduced service life. Exposing the equipment to conditions that exceeds the specifications could invalidate your warranty.

Installation

Mark the screw locations using the module as a template, and drill pilot holes. Secure the module using fasteners that are suitable for the material you are mounting the module to.

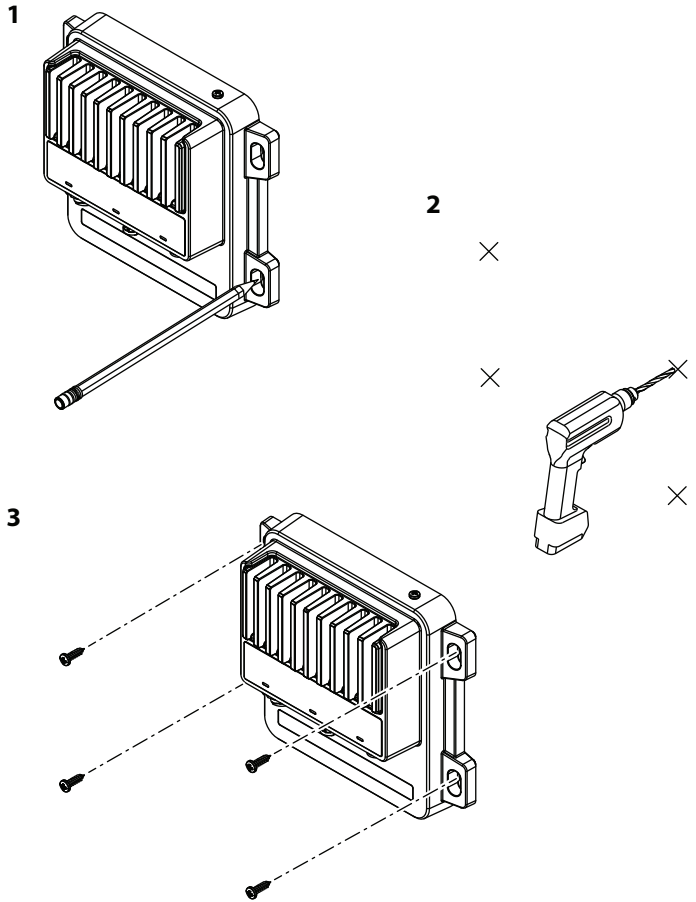

3

Transducer installation

This chapter describes how to install the transducer.

The transducer can be mounted either to the shaft or to the motor of the trolling motor.

Shaft mounting

The transducer can be oriented in three different ways; down looking, forward looking, or in scout position.

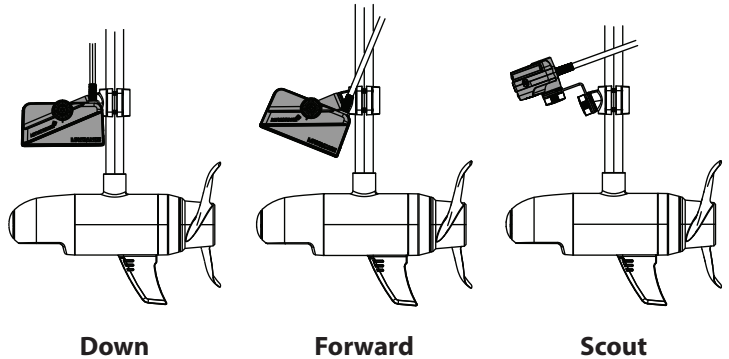

The transducer can be mounted on the port or starboard side of the shaft.

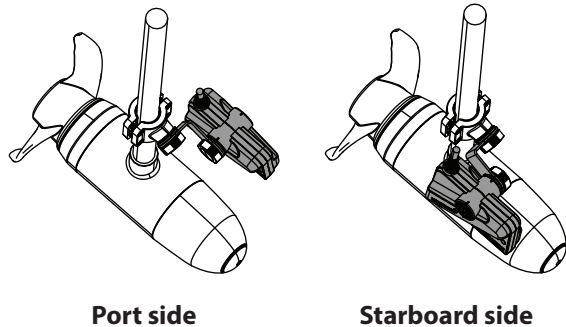

Down:

Use for vertical fishing to see what is below the transducer. Watch your lure and fish movements in real time.

Forward:

Use for seeing fish and structure directly in front of the transducer. Know the depth of the fish and structure to target your next cast.

Scout:

Use to scan large areas for fish and structure. Search for schooling fish and know the direction of your next cast.

Attach the bracket arm to the shaft front collar

Install the bracket arm in the desired position to the shaft collar. When installed, the arm can be used as a handle to align the shaft clamp with the centerline of the trolling motor.

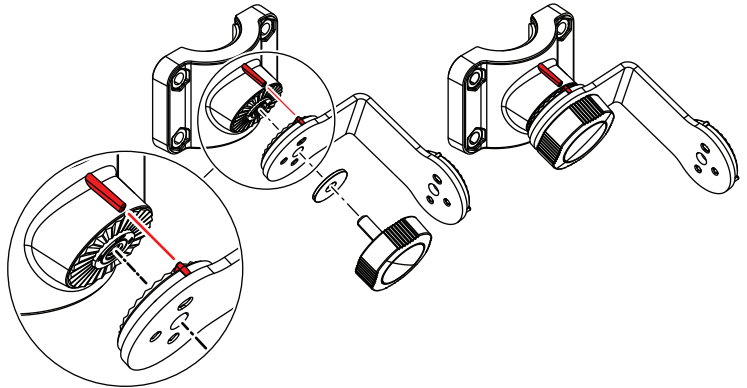
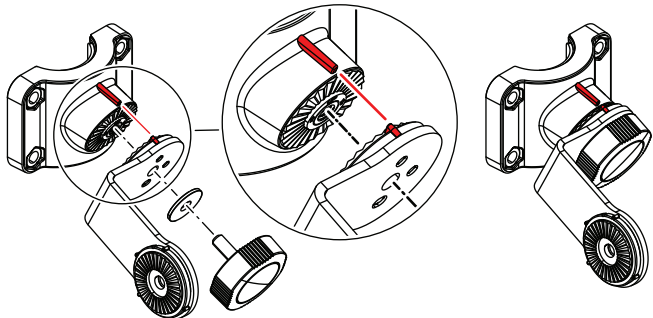
Port side - Down/Forward orientation**Starboard side - Down/Forward orientation**

Scout orientation

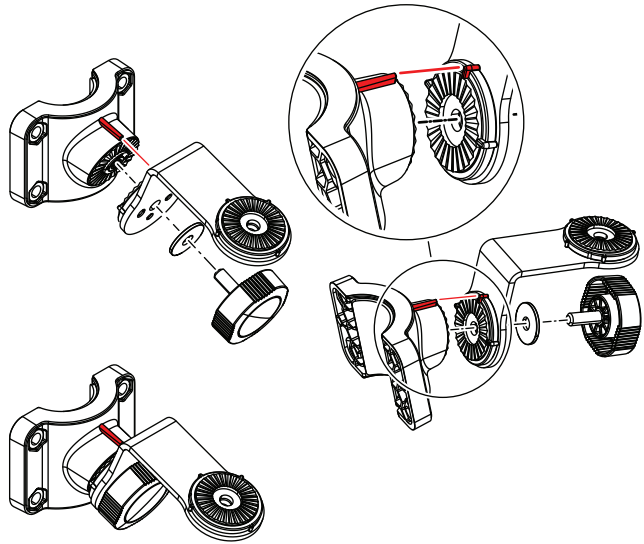

Align and attach the shaft clamp

Align the shaft bracket with the centerline of the trolling motor.

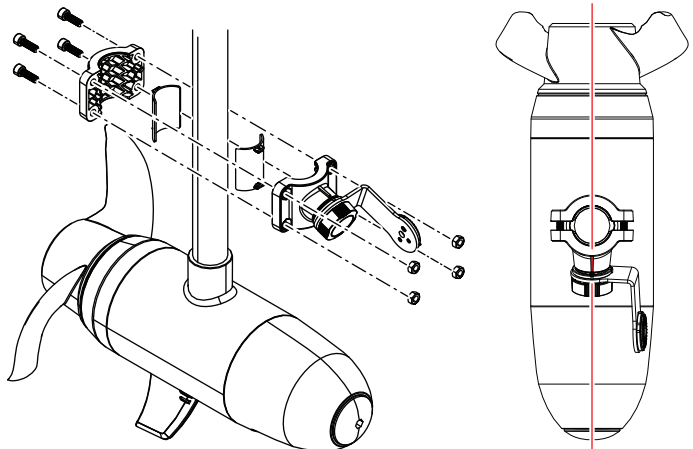

Down orientation

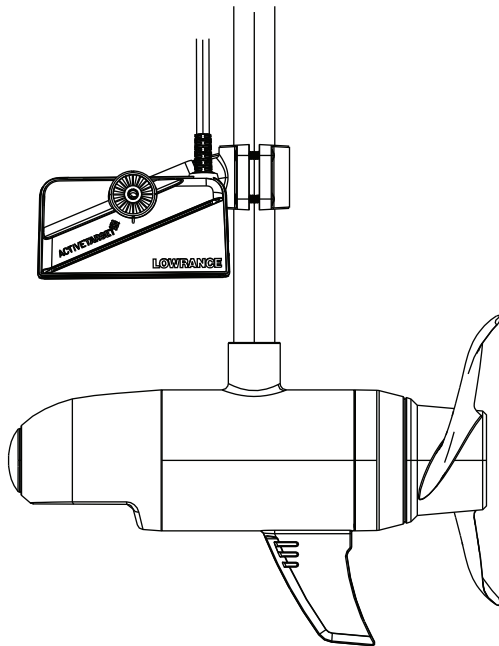
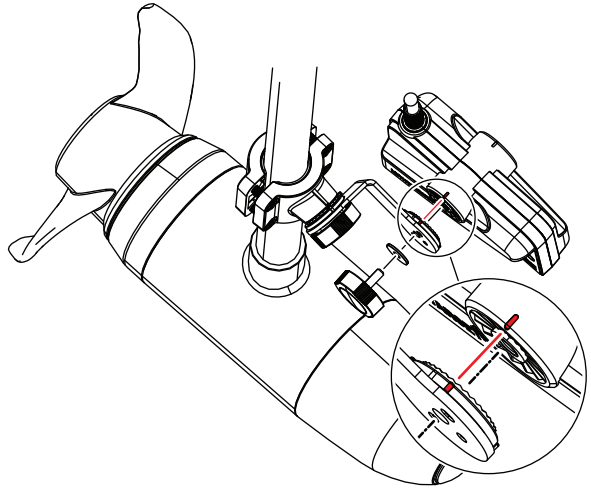

Forward orientation

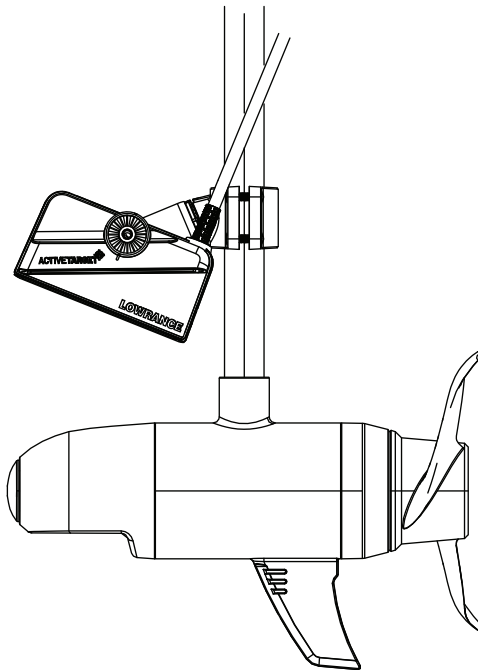
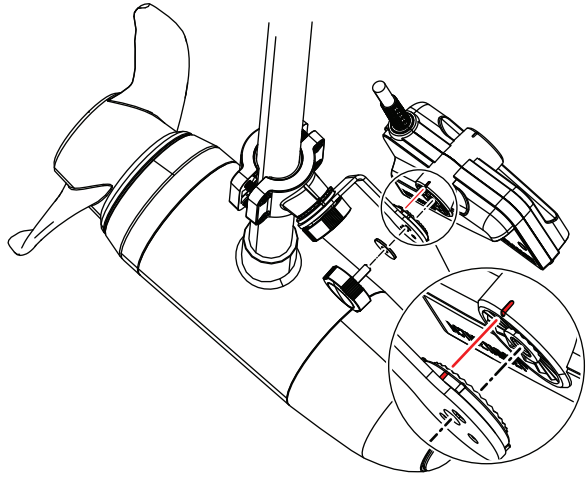

Scout orientation

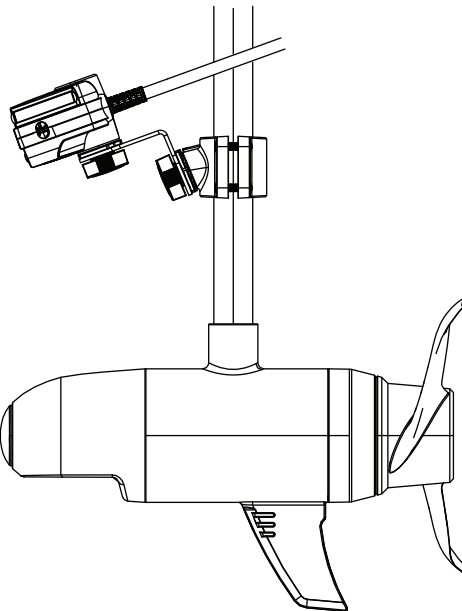
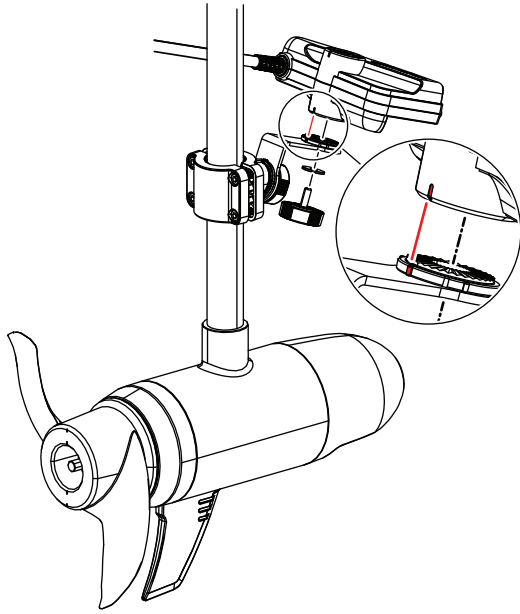

Motor mounting

The transducer can be oriented in three different ways on most motors; down looking, forward looking, or in scout position.

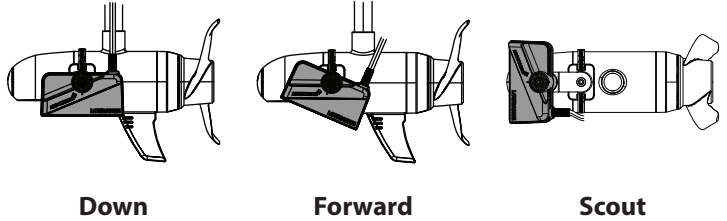

The transducer can be mounted on the port or starboard side of the shaft.

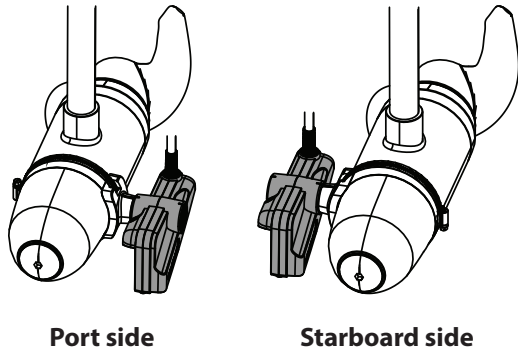

Down:

Use for vertical fishing to see what is below the transducer. Watch your lure and fish movements in real time.

Forward:

Use for seeing fish and structure directly in front of the transducer. Know the depth of the fish and structure to target your next cast.

Scout:

Use to scan large areas for fish and structure. Search for schooling fish and know the direction of your next cast.

Down orientation

Attach the bracket to the transducer. Secure the assembly to the motor using the hose clamp. The hose clamp should be tightened just enough to prevent the transducer from moving during normal use. Then orient the transducer to the down orientation by firmly gripping and rotating the transducer until the alignment marks are aligned.

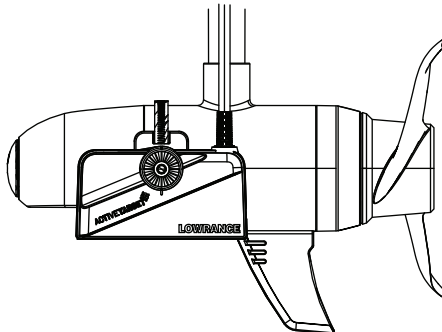
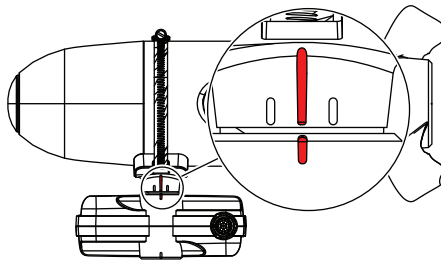
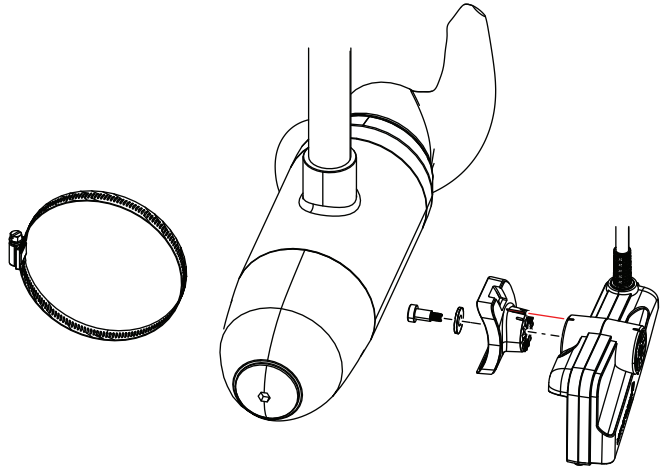

Forward orientation

Attach the bracket to the transducer. Secure the assembly to the motor using the hose clamp. The hose clamp should be tightened just enough to prevent the transducer from moving during normal use. Then orient the transducer to the forward orientation by firmly gripping and rotating the transducer until the alignment marks are aligned.

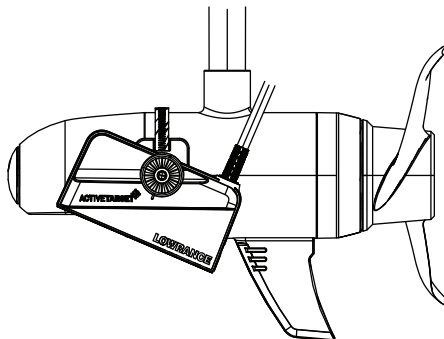
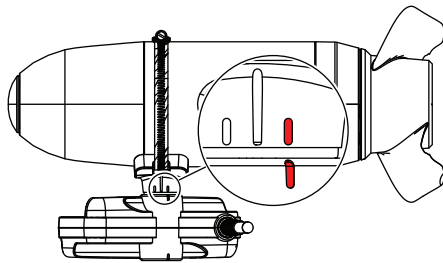
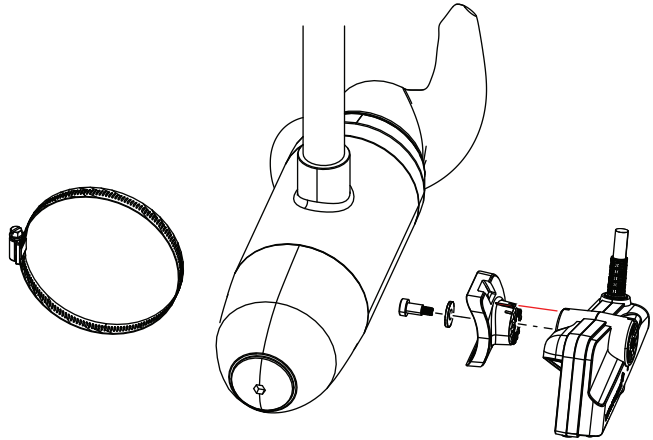

Scout orientation

Attach the transducer to the scout bracket arm. Then install the transducer and bracket arm to the bracket. Secure the assembly to the motor using the hose clamp. The orientation can be adjusted by firmly gripping and rotating the transducer until the alignment marks are aligned.

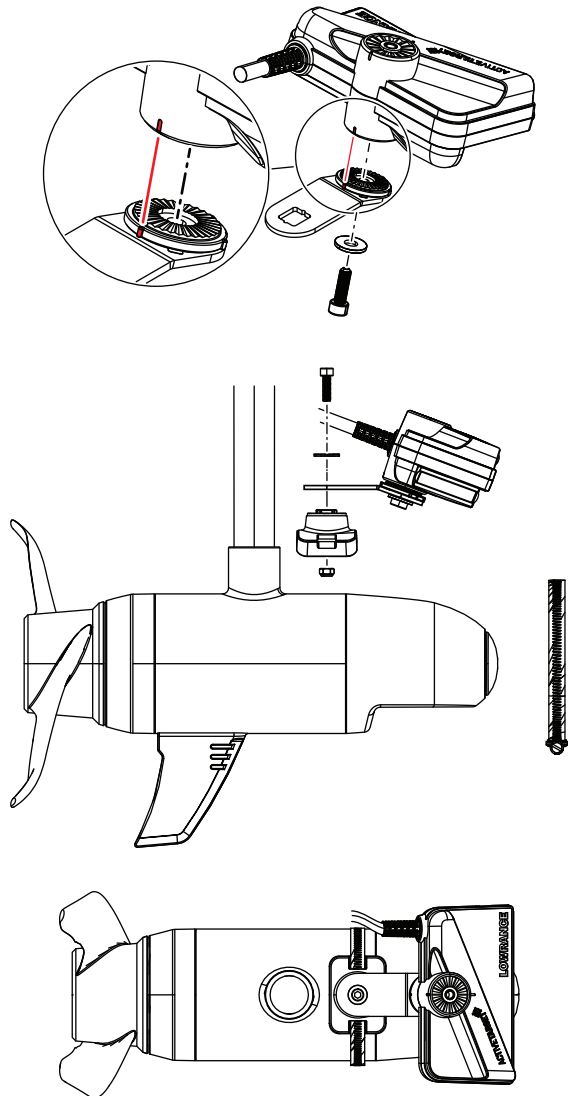

4

Wiring

This chapter describes how to wire the sonar system.

Guidelines

Do not:

- Make sharp bends in the cables.
- Run cables in a way that allows water to flow down into the connectors.
- Run the data cables adjacent to radar, transmitter, or large/high current carrying cables or high frequency signal cables.
- Run cables so they interfere with mechanical systems.
- Run cables over sharp edges or burrs.

Do:

- Make drip and service loops.
- Use cable-ties on all cables to keep them secure.
- Solder/crimp and insulate all wiring connections if extending or shortening the cables.
- Leave room adjacent to connectors to ease plugging and unplugging of cables.

! Warning: Before starting the installation, be sure to turn electrical power off. If power is left on or turned on during the installation, fire, electrical shock, or other serious injury may occur. Be sure that the voltage of the power supply is compatible with the unit.

Wiring overview

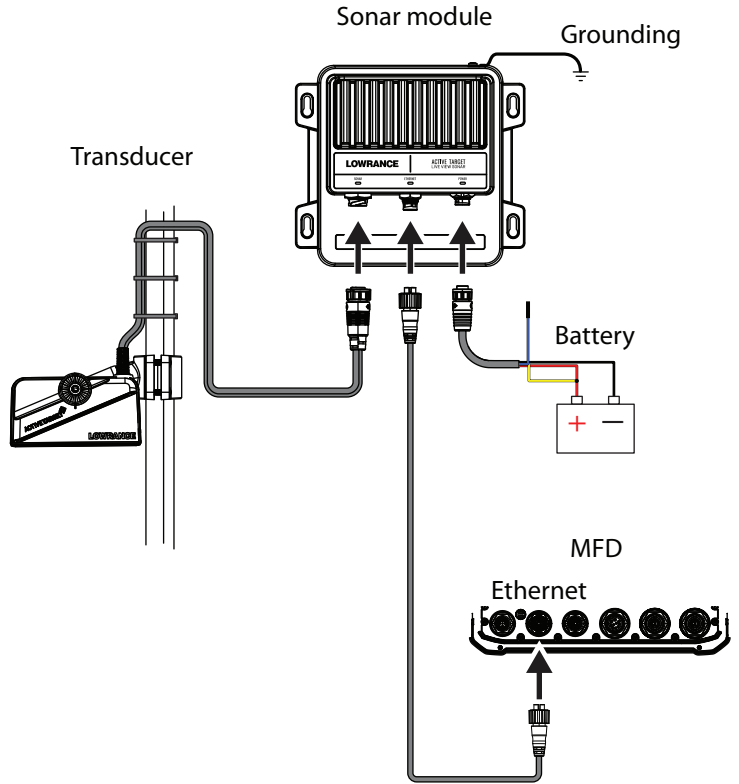

Transducer

Leave enough slack in the cable so the transducer can be adjusted to all possible orientations (Forward/Down/Scout). There also needs to be enough slack in the cable loop so that the motor shaft can spin all the way around without damaging the cable.

Connect the transducer to the sonar port of the module.

Make sure that the cable is properly supported.

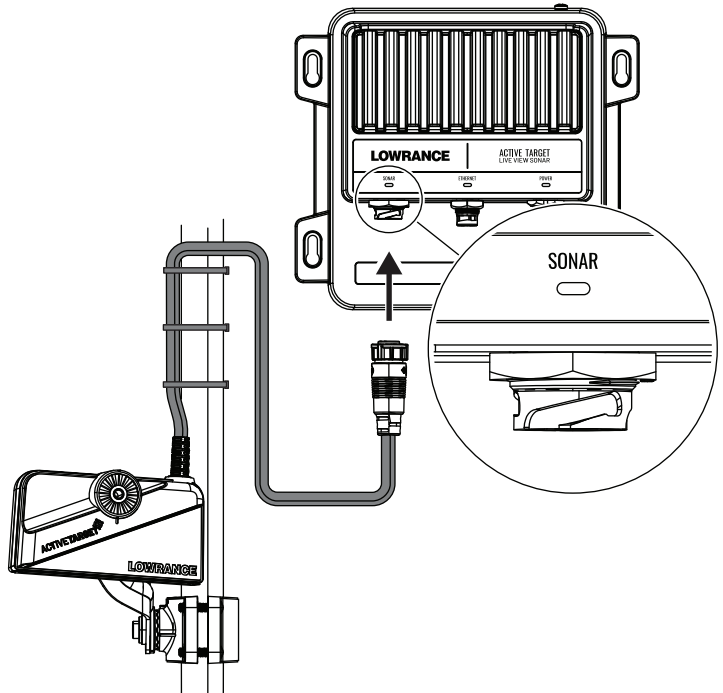

Ethernet

Connect the Ethernet cable to the Ethernet port of the module. The other end should be connected to your display unit or Ethernet expansion device.

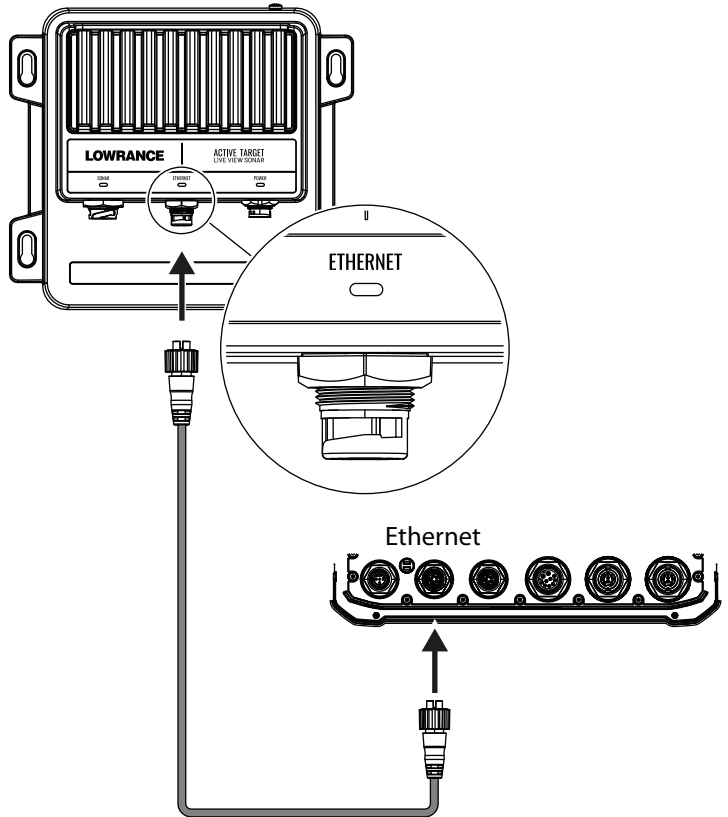

Power

The unit is designed to be powered by a 12 or 24 V DC system. It is protected against reverse polarity, under voltage, and over voltage (for a limited duration).

A fuse or circuit breaker should be fitted to the positive supply. For recommended fuse rating, refer to “Technical specification” on page 30.

The yellow wire in the power cable is used to control how the unit is turned on and off.

The blue wire should not be used.

! Warning: The positive supply wire (red) should always be connected to (+) DC with a fuse or a circuit breaker (closest available to fuse rating).

Power controlled by external switch

The unit will turn ON/OFF when power is applied/removed.

Connect the yellow wire to the red wire via a switch after the fuse.

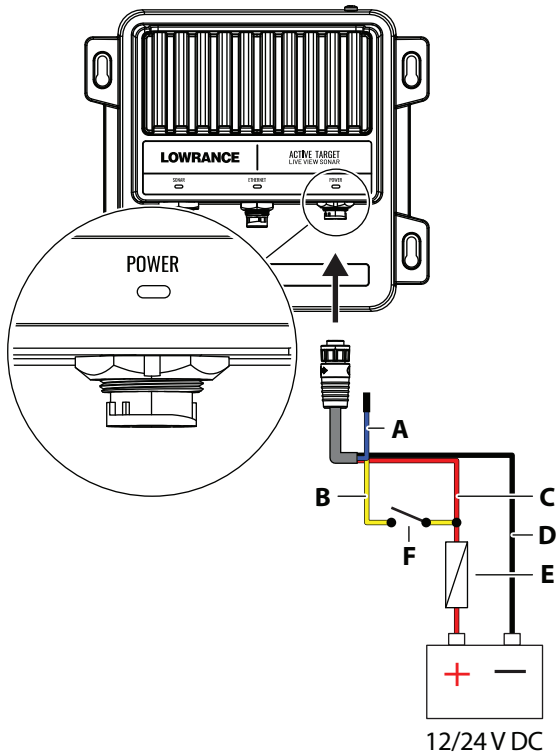

Key	Description	Color
A	Not used	Blue
B	Accessory wake up	Yellow
C	+ 12/24 V DC	Red
D	DC Negative	Black
E	Fuse	
F	Switch	

Power controlled by power bus/display unit

The unit will turn ON/OFF when power is applied/removed. By connecting the yellow wire to a display unit's yellow wire, the sonar module will turn on the moment the display unit is powered up.

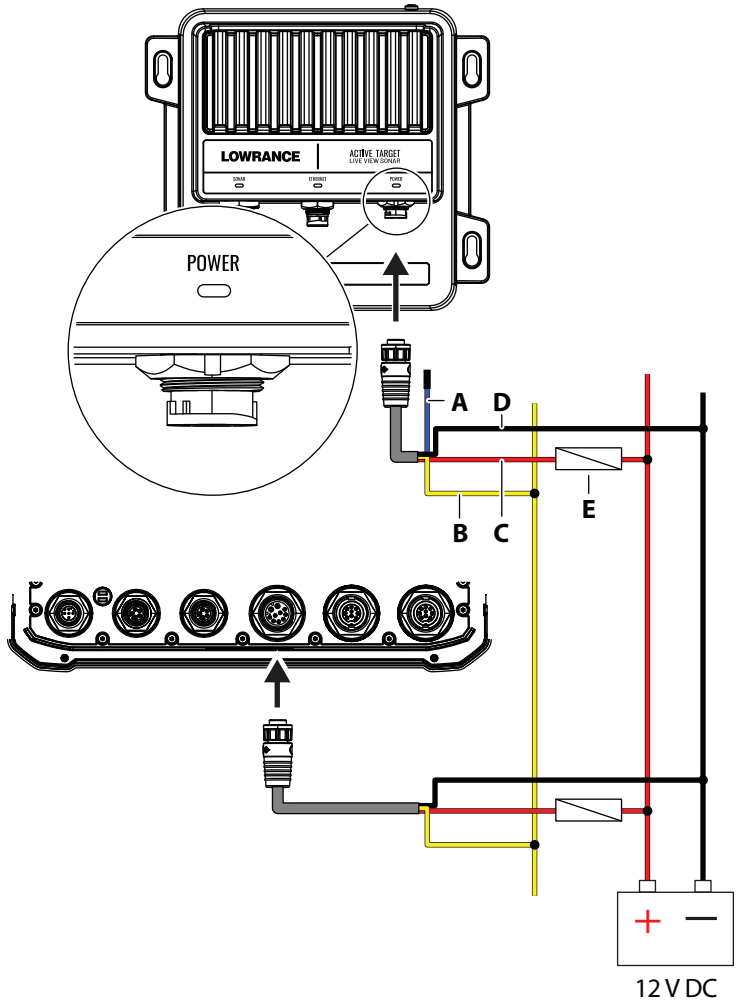

Key	Description	Color
A	Not used	Blue
B	Accessory wake up	Yellow
C	+ 12V DC	Red
D	DC Negative	Black
E	Fuse	

Grounding

The grounding terminal is DC isolated from power to eliminate the risk of galvanic corrosion.

For installations that suffer from noise issues, the grounding terminal allows for the option to connect to various possible ground points. The grounding point can be the vessel's bonded ground/earth, non bonded RF Ground, or battery minus (DC negative).

It is recommended to use a 4 mm² (12 AWG) or thicker wire.

→ **Note:** No DC power will flow through the connected conductor.

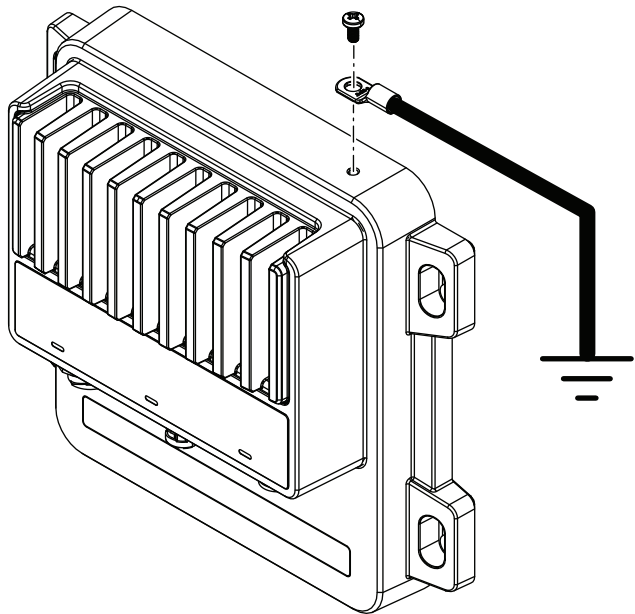

LED indicators

The LEDs on the sonar module indicate the status of the module.

LED	Description
Power	Solid green during power up. When started the led will alternate between green and red.
Ethernet	Flashes when there is network activity.
Transducer	Solid green when active. OFF when deactivate.

5

Dimensional drawings

Sonar module

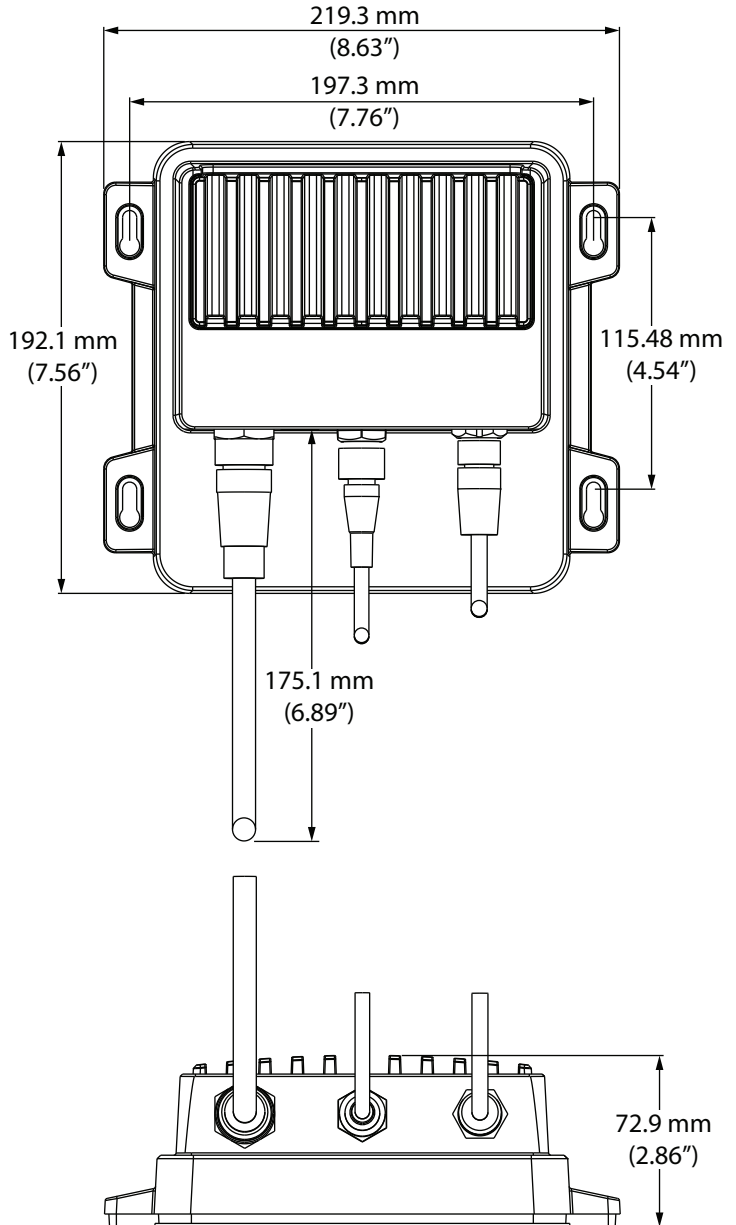

Transducer

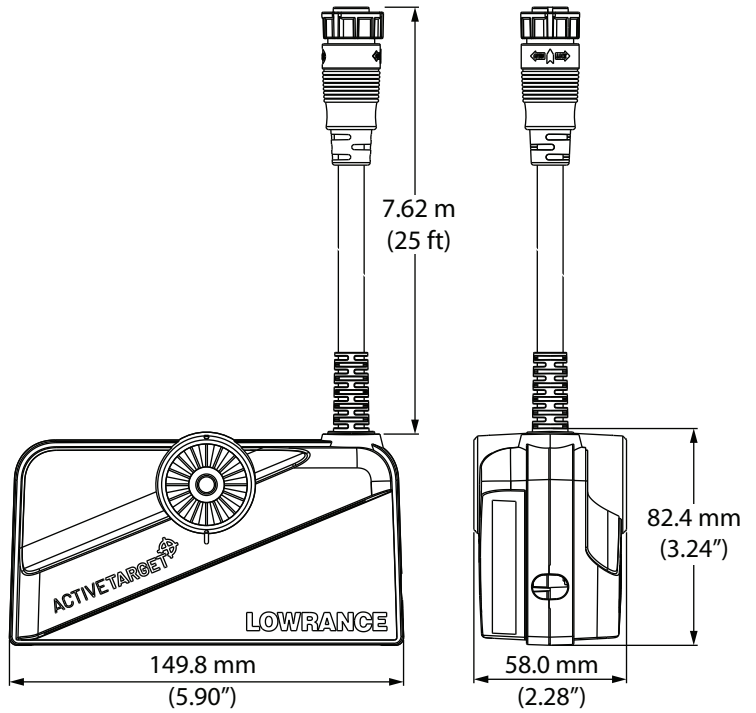

6

Technical specification

Sonar module

Environmental	
Storage temperature	-30°C to +70°C (-22°F to +158°F)
Operating temperature	-15°C to +55°C (5°F to 131°F)
IP class	IP67
Electrical	
Power supply	12/24 V DC
Operating voltage	10.8 V DC - 31.2 V DC
Current drain (maximum)	1.5A at 13.8V
Reverse polarity protection	Yes
Fuse rating	3 A
Physical	
Weight	1.86 kg (4.12 lbs)

Transducer

Environmental	
Storage temperature	-30°C to +70°C (-22°F to +158°F)
Water temperature for operation	0°C to +35°C (32°F to +95°F)
Physical	
Weight	1.21 kg (2.67 lbs)
Cable length	7.62 m (25 ft)
Mounting options	Trolling motor shaft Trolling motor lower unit Transom mount (sold separately)