

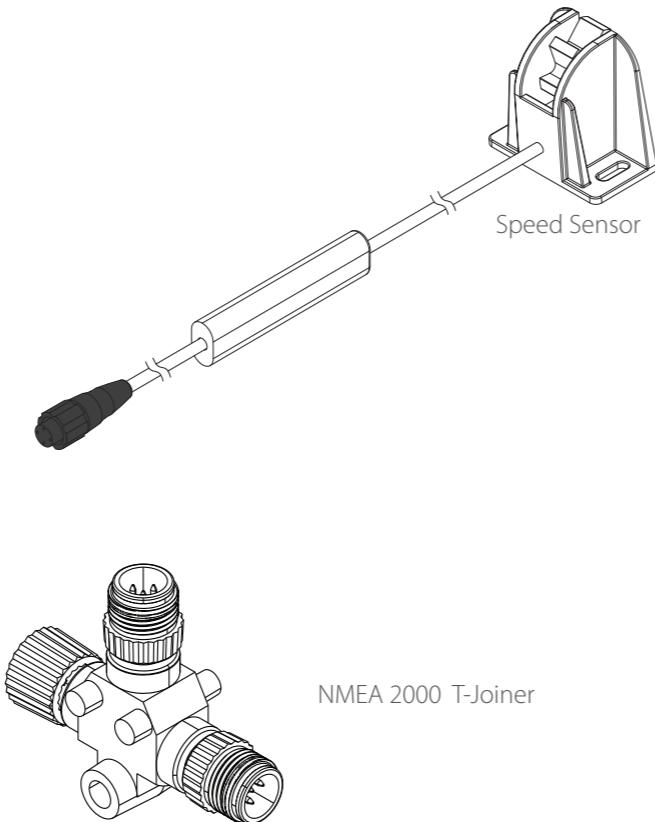

What's in the box

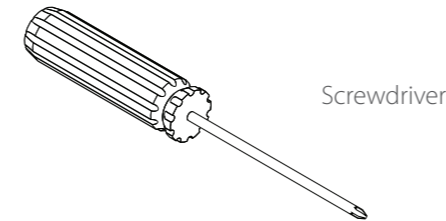

Tools required

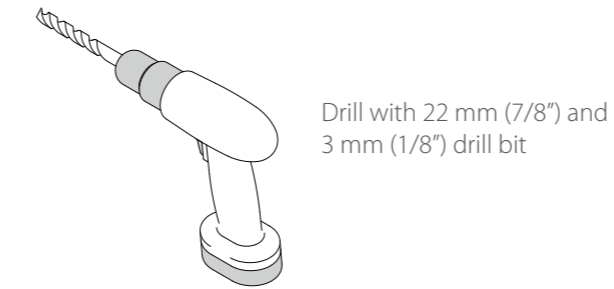

Other parts required

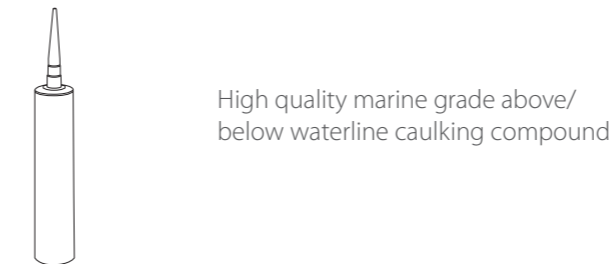
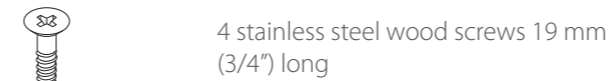

Overview

The Speed Sensor converts analog speed data to the NMEA 2000 data format.

⚠ You should read all of the installation instructions before proceeding. Decide where to install all components before drilling any holes in your vessel.

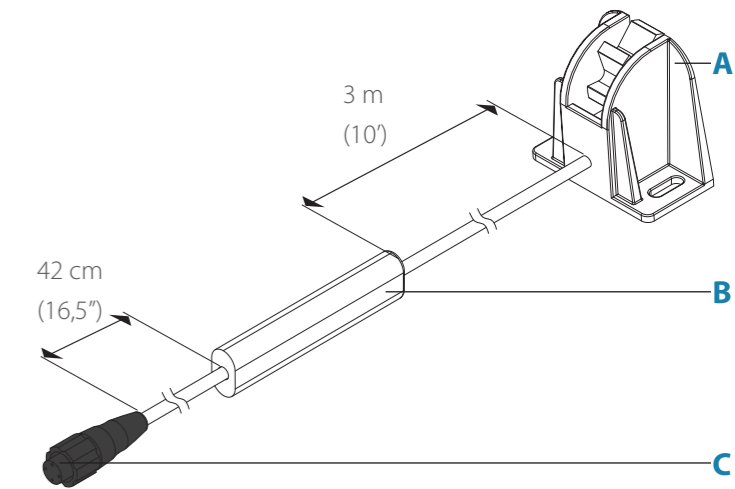

- A Paddle wheel with speed sensor
- B Processing unit
- C NMEA 2000 connector

Plan the installation

To install the speed sensor, first find a location on the boat's transom where the water flow is smoothest. Don't mount the sensor behind strakes or ribs. These will disturb the water flow to the speed sensor. Make sure the sensor will remain in the water when the boat is on plane. Also make sure the location doesn't interfere with the boat's trailer. Typically, the sensor is mounted about one foot to the side of the transom's centerline.

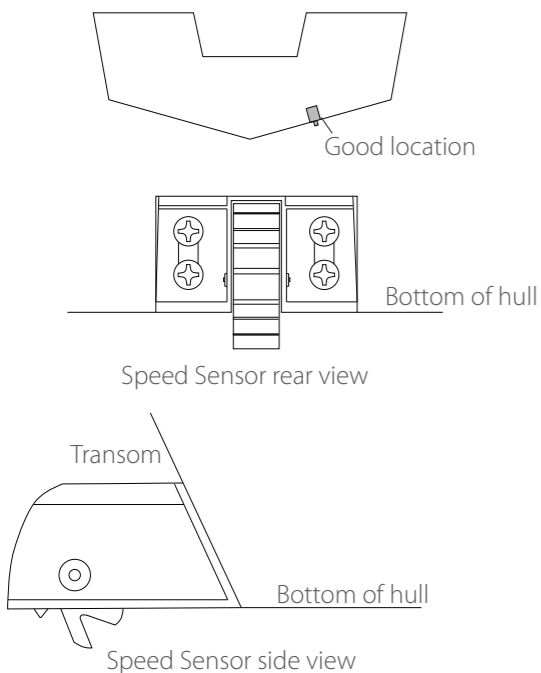

Install the Speed Sensor

Once you've determined the proper location for the unit, place the sensor on the transom with the bracket flush with the hull's bottom. Using the sensor as a template, mark the hull for the screws' pilot holes (1). Drill four 3 mm (1/8") holes, one in each end of the slots (2). Mount the sensor to the hull using #8 stainless steel wood screws (3). Use a high quality, marine grade above- or below-waterline sealant to seal the screws. Make sure the sensor is flush with the bottom of the hull and tighten the screws.

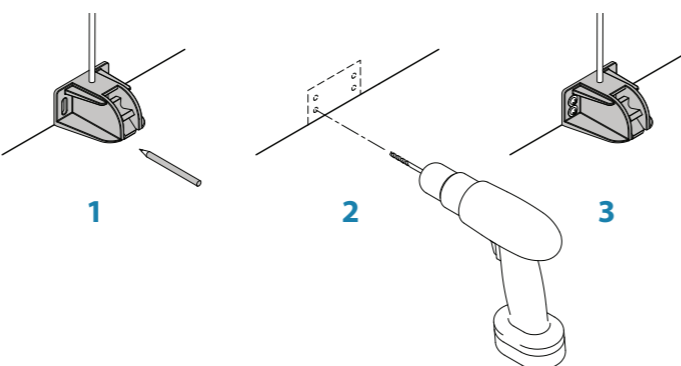

If the base of the transom has a radius, fill the gap between the transom and the sensor with sealant. This will help ensure a smooth water flow.

⚠ If you drill a hole in the transom for the cable, make sure it is located above the waterline. After installation, be sure to seal the cable hole with the same marine grade above-or below-waterline sealant used for the screws.

Connect the Speed Sensor to the network

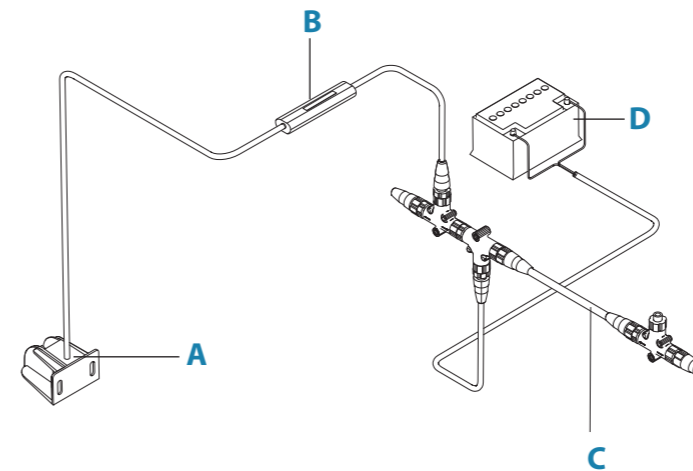

- A Paddle wheel with speed sensor
- B Processing unit
- C NMEA 2000 CAN bus backbone
- D 12 V DC Power supply. Connect via a switch and 5 amp fuse

Dimensions

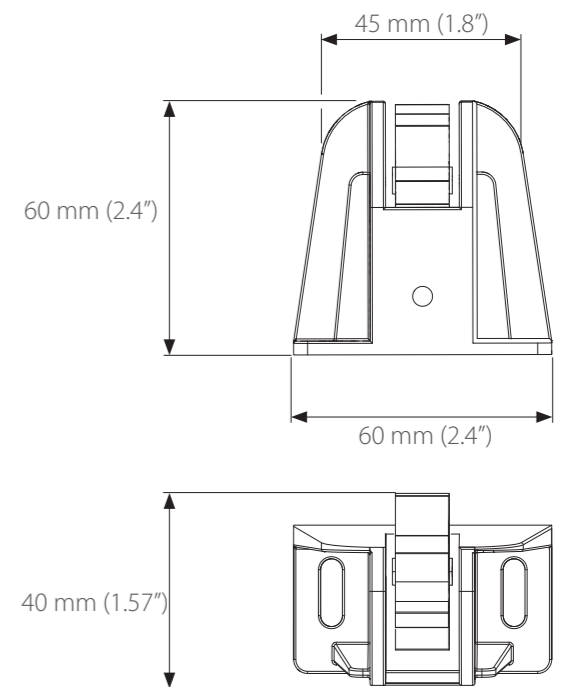

Specifications

Speed Range between 0 and 80 km/h.
PGNs transmitted
59392 – ISO Acknowledgment
60928 – ISO Address Claim
126996 – Product Information
128259 – Speed, Water Referenced