



WMW Wiper Motor Windshield Frame Mount Installation Instructions

PLEASE READ THROUGH ALL INSTRUCTIONS PRIOR TO INSTALLATION

This motor has a water-resistant housing, and may be installed in locations that are exposed to moisture.

Tools required for installation and/or adjustment:

- Phillips head screwdriver
- #8 self-tapping screw (1)
- Drill
- 7/16" drill bit
- 9/64" drill bit
- 14 mm or small adjustable wrench
- 3 Amp fuse and fuse carrier
- On/Off switch (if new installation)
- 16 gauge stranded wire
- 16-14 gauge crimp-on butt connectors (2-3)
- Crimping/Cutting pliers
- Electrical Tape

INSTALLATION:

Note: This wiper motor is intended for use with wiper arm /blade combinations no larger than 14" x 14".

1. This wiper motor can be mounted above or below the windshield. Make sure that the installation location you have selected will provide ample clearance for the sweep of the wiper blade and arm. For optimum performance, mount the wiper motor shaft at a 90° angle to the windshield. This will minimize strain on the wiper motor.

2. Drill the shaft mounting hole in the location you have selected. Use a 7/16" drill for the 3/8" diameter shaft.

3. Remove the knurled retainer ring, stainless steel nut and washer and smaller rubber grommet from the shaft. Mount the motor in the windshield frame with the large grommet on the inside of the frame. Place the small grommet over the shaft on

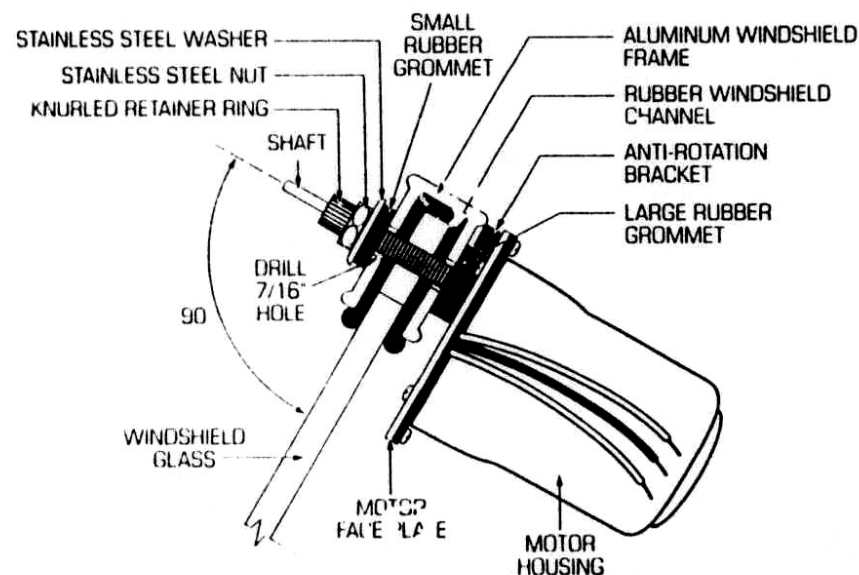

the outside of the frame followed by the washer and nut. Use a 14 mm or small adjustable wrench to tighten the nut snugly. Do not over-tighten. Install the knurled retainer ring. Be sure the rubber grommets are on both sides of the frame.

4. Mark the desired hole position of the anti-rotation bracket and drill a 9/64" hole. Use a #8 self-tapping screw (not provided) to attach to most aluminum frames.

WIRING:

This motor is designed with three connections: the black wire is the negative (-) connection, the blue wire is the positive (+) connection and the red wire is the switch (S) connection. Refer to the wiring diagram for proper installation. 16 gauge stranded wire is recommended. This motor can be wired for regular operation or self-parking operation. We strongly recommend that a 3 amp fuse be used to insure safe and reliable operation.

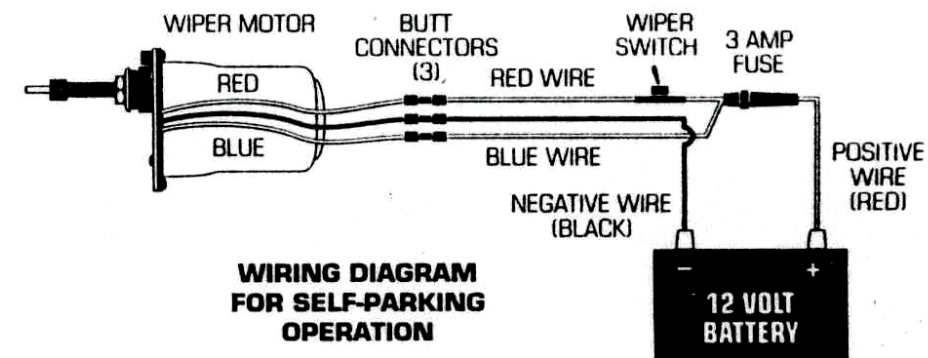
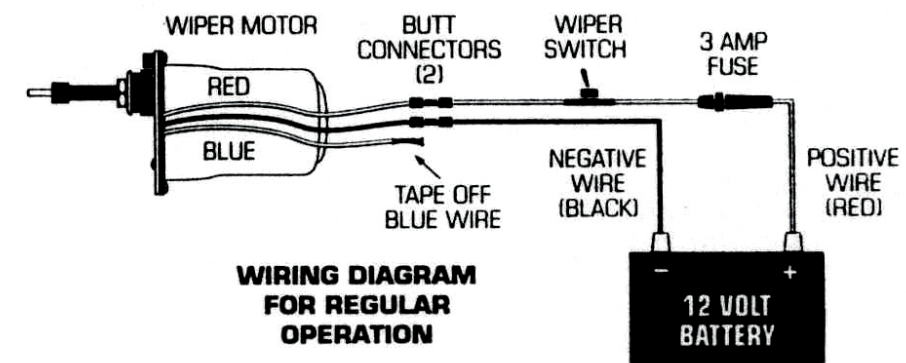

Strip 1/4" of insulation from each of the wires on the motor. Attach wiring together with crimp-on butt connectors and seal with electrical tape. If the blue wire is not used, seal off and insulate the end of the wire with electrical tape.

TROUBLESHOOTING:

If motor does not operate, double check wiring connections and 3A fuse.

