



STD Wiper Motor Deck Mount Installation Instructions

**PLEASE READ THROUGH ALL INSTRUCTIONS
PRIOR TO INSTALLATION**

This motor is not waterproof and should be installed in a protected area away from moisture and water spray.

Tools required for installation and/or adjustment:

- Phillips head screwdriver
- Small flat blade screwdriver
- Drill
- 5/8" drill bit
- 3/16" drill bit
- 5/8" hole saw or jig saw
- Tape measure
- 1/4" or 1/2" round file
- Silicone Sealant
- 3 Amp fuse and fuse carrier
- On/Off switch (if new installation)
- 16 gauge stranded wire
- Ring terminals, 16-14 gauge wire size, 4-6 stud size (2-3)
- Crimping/Cutting pliers
- Deck mount adapter kit, AFI part # 33000

INSTALLATION:

Note: This wiper motor is intended for use with wiper arm/blade combinations no larger than 14" x 14".

1. This wiper motor is designed to be mounted below the deck in front of the windshield. The mounting position should be as close to the base of the windshield as possible. Determine that there is adequate motor clearance under the deck prior to installation. Make sure that the installation location you have selected will provide ample clearance for the sweep of the wiper blade and arm. The motor should be installed so that the motor shaft is pointing away from the windshield. The deck mount adapter plate (AFI part # 33000) and 3-1/2" shaft can be installed in decks up to 1/2" thick. To install in thicker decks, material from the underside of the deck will need to be removed until a 1/2" thickness is achieved and there is ample clearance for the motor. For best operation, the motor shaft should be at an approximate 90° angle to the windshield. This will reduce strain on the wiper motor.

2. Mark the location of the deck mount adapter plate. See the mounting hole diagram. Mark the two 5/8" diameter holes spaced 11/16" apart (center line to center line) and drill. Remove the material between the holes with a hole

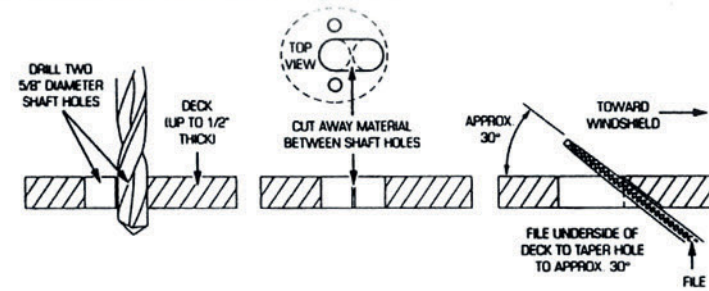
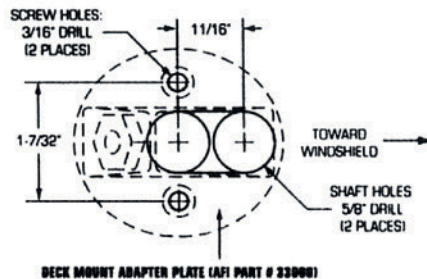

saw or jig saw. From under the deck surface, use a round file to add a 30° bevel on the edge of the hole closest to the windshield. Mark and drill two 3/16" diameter screw holes 1-7/32" apart.

3. Remove all the shaft hardware and grommets and discard. Leave the o-ring on the end of the shaft. Insert the motor shaft through the opening under the deck. Slip the locking plate over the shaft making sure that the tabs are up and point toward the windshield. Screw the deck mount adapter plate on to the motor shaft. Tighten the plate until it is snug and the flat sides of the motor shaft are aligned with the tabs on the locking plate. This procedure may require a second set of hands. Apply some silicone sealant around the edges of the deck holes and secure the deck mount adapter and locking plate to the deck with the adapter kit hardware.

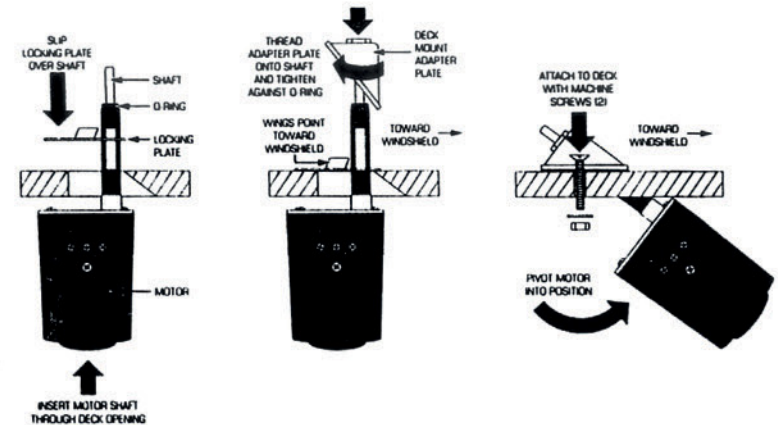

WIRING:

This motor has three connections, negative (-), positive (+), and switch (S) marked on the side of the motor housing. Use black or yellow wire for the negative connection, blue wire for the positive connection and red wire for the switch connection. 16 gauge stranded wire is recommended. This motor can be wired for regular operation or self-parking operation. Refer to the wiring diagram for proper installation. We strongly recommend that a 3 amp fuse be used to insure safe and reliable operation.

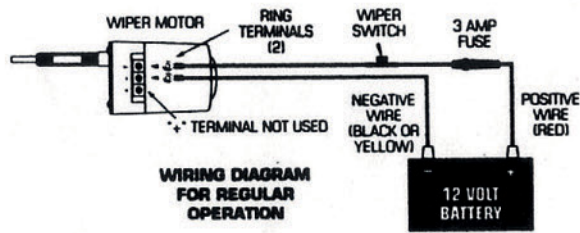
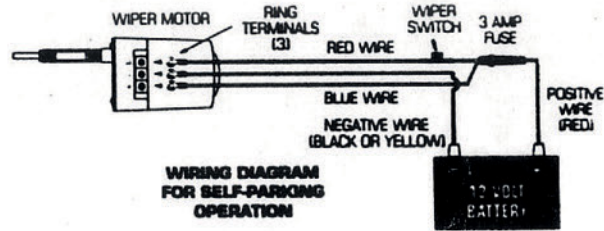

CHANGING THE PARKING POSITION:

1. Use a Phillips head screwdriver to remove the two motor housing screws located on the sides of the motor housing. Pull off the motor housing.
2. Use a small flat blade screwdriver to carefully remove the o-ring and white nylon cam from the gear shaft. Rotate the white cam 180° from the original position and reinstall it back onto the gear shaft. Be sure that the cam is pushed all the way back onto the gear shaft and the o-ring is properly seated in place.

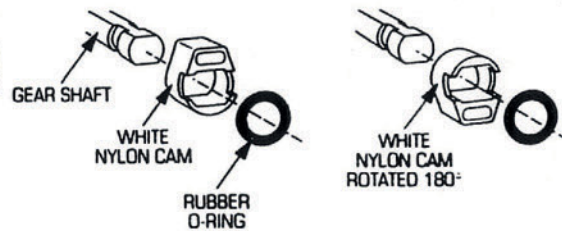
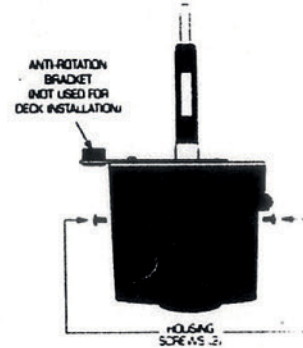

3. Re-install the motor housing back onto the motor and replace the two Phillips head motor housing screws.

CHANGING THE WIPING ANGLE.

1. Use a Phillips head screwdriver to remove the 4 wiper motor face plate screws.
2. Remove the wiper motor face plate by pulling the motor shaft straight up.
3. Use a Phillips head screwdriver to remove the position screw from the transmission arm plate. Be careful not to lose the position screw bushing and washers.

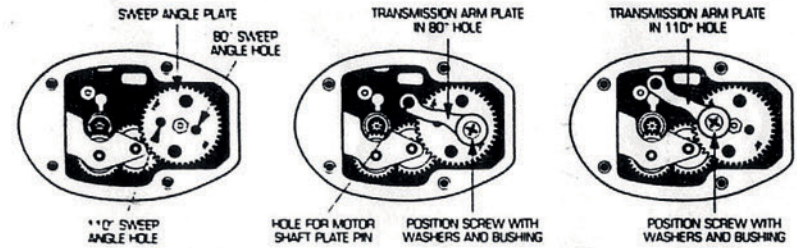
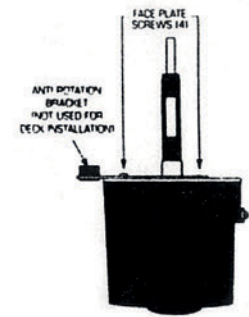

4. Relocate the transmission arm plate to the desired sweep angle hole on the round sweep angle plate. The sweep angles are stamped onto the sweep angle plate. Re-install the transmission arm plate on to the sweep angle plate with the position screw. Be sure the position screw bushing is installed inside the transmission arm plate and washers are on both sides of the transmission arm. Do not over-tighten the position screw.

5. Insert the wiper motor shaft plate pin back into the hole on the end of the transmission arm plate. It may be necessary to rotate the motor shaft to get the pin to properly align in the transmission arm plate. Re-attach the wiper motor face plate to the motor body with the 4 Phillips head screws.

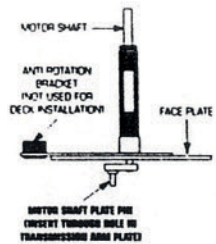

Note:

After changing the wiping angle, the wiper motor parking position will automatically change to the opposite side. If necessary, readjust the parking position as described in the "Changing Parking Position" instructions.

TROUBLESHOOTING:

If motor does not operate, double check wiring connections and 3A fuse.



STD Wiper Motor Windshield Frame Mount Installation Instructions

PLEASE READ THROUGH ALL INSTRUCTIONS PRIOR TO INSTALLATION

This motor is not waterproof and should be installed in a protected area away from moisture and water spray.

Tools required for installation and/or adjustment:

- Phillips head screwdriver
- Small flat blade screwdriver
- #8 self-tapping screw (1)
- Drill
- 7/16" drill bit
- 9/64" drill bit
- 14 mm or small adjustable wrench
- 3 Amp fuse and fuse carrier
- On/Off switch (if new installation)
- 16 gauge stranded wire
- Ring terminals, 16-14 gauge wire size, 4-6 stud size (2-3)
- Crimping/Cutting pliers

INSTALLATION:

Note: This wiper motor is intended for use with wiper arm/blade combinations no larger than 14" x 14".

1. This wiper motor can be mounted above or below the windshield. Make sure that the installation location you have selected will provide ample clearance for the sweep of the wiper blade and arm. For optimum performance, mount the wiper motor shaft at a 90° angle to the windshield. This will minimize strain on the wiper motor.

2. Drill the shaft mounting hole in the location you have selected. Use a 7/16" drill for the 3/8" diameter shaft.

3. Remove the knurled retainer ring, stainless steel nut and washer and smaller rubber grommet from the shaft. Mount the motor in the windshield frame with the large grommet on the inside of

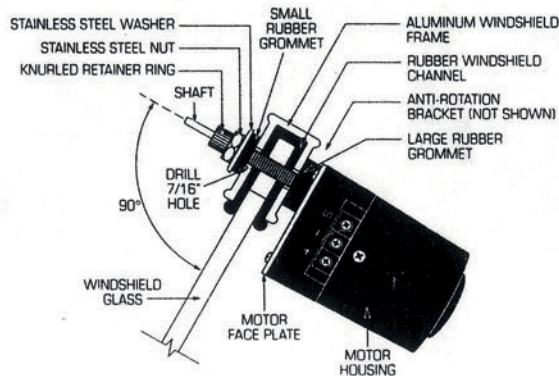

the frame. Place the small grommet over the shaft on the outside of the frame followed by the washer and nut. Use a 14 mm or small adjustable wrench to tighten the nut snugly. Do not over-tighten. Install the knurled retainer ring. Be sure the rubber grommets are on both sides of the frame.

4. Mark the desired hole position of the anti-rotation bracket and drill a 9/64" hole. Use a #8 self-tapping screw (not provided) to attach to most aluminum frames.

WIRING:

This motor has three connections, negative (-), positive (+), and switch (S) marked on the side of the motor housing. Use black or yellow wire for the negative connection, blue wire for the positive connection and red wire for the switch connection. 16 gauge stranded wire is recommended. This motor can be wired for regular operation or self-parking operation. Refer to the wiring diagram for proper installation. We strongly recommend that a 3 amp fuse be used to insure safe and reliable operation.

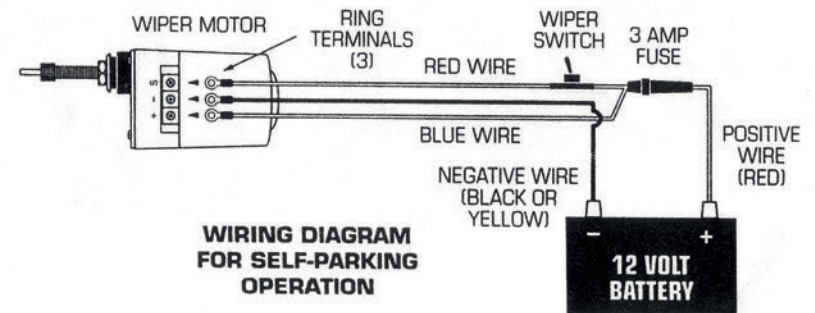
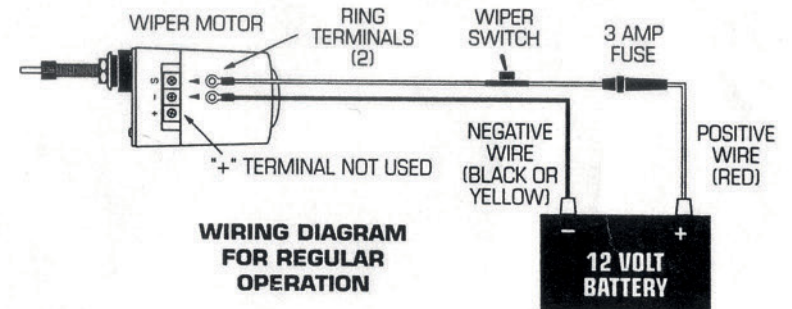

CHANGING THE PARKING POSITION:

1. Use a Phillips head screwdriver to remove the two motor housing screws located on the sides of the motor housing. Pull off the motor housing.

2. Use a small flat blade screwdriver to carefully remove the o-ring and white nylon cam from the gear shaft. Rotate the white cam 180° from the original position and reinstall it back onto the gear shaft. Be sure that the cam is pushed all the way back onto the gear shaft and the o-ring is properly seated in place.

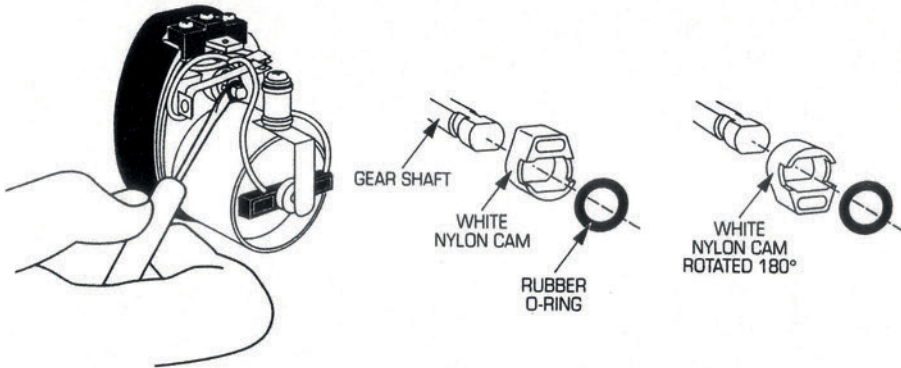
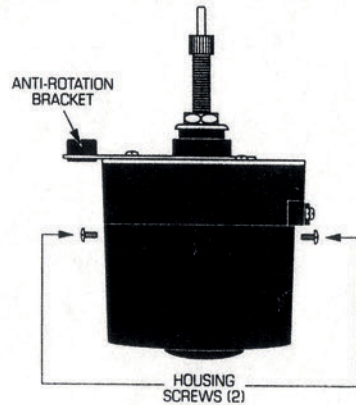

3. Re-install the motor housing back onto the motor and replace the two Phillips head motor housing screws.

CHANGING THE WIPING ANGLE:

1. Use a Phillips head screwdriver to remove the 4 wiper motor face plate screws.

2. Remove the wiper motor face plate by pulling the motor shaft straight up.

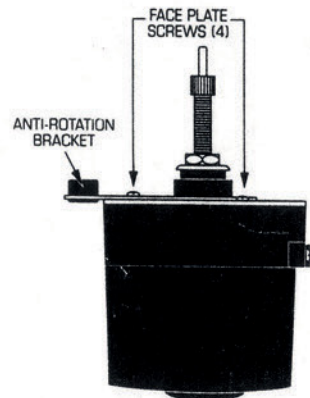

3. Use a Phillips head screwdriver to remove the position screw from the transmission arm plate. Be careful not to lose the position screw bushing and washers.

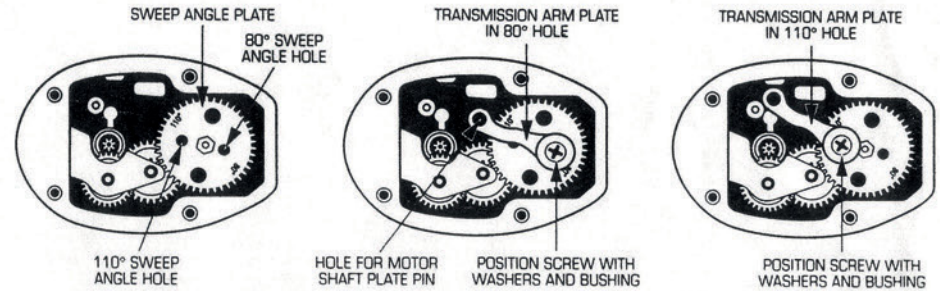

4. Relocate the transmission arm plate to the desired sweep angle hole on the round sweep angle plate. The sweep angles are stamped onto the sweep angle plate. Re-install the transmission arm plate on to the sweep angle plate with the position screw. Be sure the position screw bushing is installed inside the transmission arm plate and washers are on both sides of the transmission arm plate. Do not over-tighten the position screw.

5. Insert the wiper motor shaft plate pin back into the hole on the end of the transmission arm plate. It may be necessary to rotate the motor shaft to get the pin to properly align in the transmission arm plate. Re-attach the wiper motor face plate to the motor body with the 4 Phillips head screws.

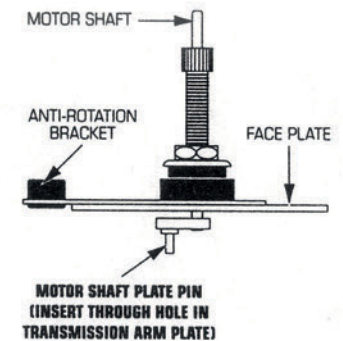

Note:

After changing the wiping angle, the wiper motor parking position will automatically change to the opposite side. If necessary, readjust the parking position as described in the "Changing Parking Position" instructions.

TROUBLESHOOTING:

If motor does not operate, double check wiring connections and 3A fuse.

