



QUALITY MARINE ACCESSORIES

INSTALLATION INSTRUCTIONS

The Model MRV heavy duty wipers offer both the features of self parking and possibility to change the sweep. The two speed models also provide slow and fast sweeps:

Slow: 32-40 sweeps a minute

Fast: 52-60 sweeps a minute

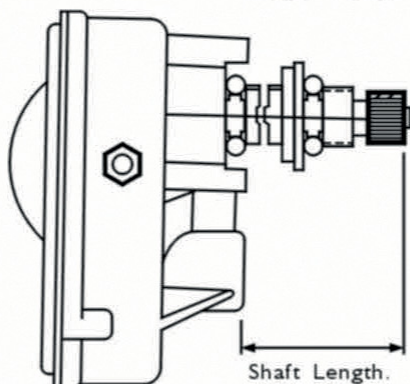

Model Nr.	Sweep*	Shaft Length
34000	80°	2½" (63.5mm)
34010	110°	" "
34001	80°	1½" (38.1mm)
34011	110°	" "
34005	80°	3½" (88.9mm)
34015	110°	" "

*Motors are adjusted to these standard sweep angles in production which can be changed to other angles, if necessary.

MODEL MRV TWO SPEED

Heavy-Duty Wiper Motor



MOUNTING & WIRING

- Locate proper mounting position of wiper assembly.
- Determine whether adequate space is available and see that blade will wipe the desired area of windshield.
- Distance between shaft hole and bracket hole should be 6- $\frac{1}{4}$ " (159 mm).
- Drill wiper shaft hole first using a 5/8" (16 mm) diameter. It may also be necessary to slightly enlarge hole after drilling to facilitate ease of installation.
- The mounting bracket hole may now be drilled. A number 10 size screw is required (not supplied).
- The wiper motor may now be placed in position and the wiper shaft attaching nut and washers installed. This nut should be tightened to 30-50 in lbs. (35-58 kg. cms). Caution: do not over tighten.
- Wiring - a simple wiring diagram is shown below.

For marine applications where mounting is of wood, fiberglass, etc., a separate ground wire must be attached to the motor and connected to a battery ground point.

NOTE: Blade and arm should be installed approximately 1" (25.4 mm) minimum away from windshield molding. Energize the motor for short intervals to make certain the wiper blade does not strike at either end of the wiping arc. If blade strikes at both ends, it will be necessary to shorten the arm and blade length.

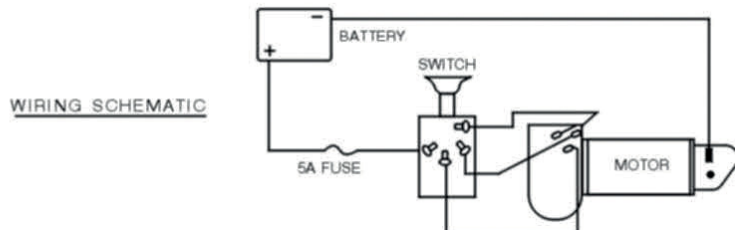
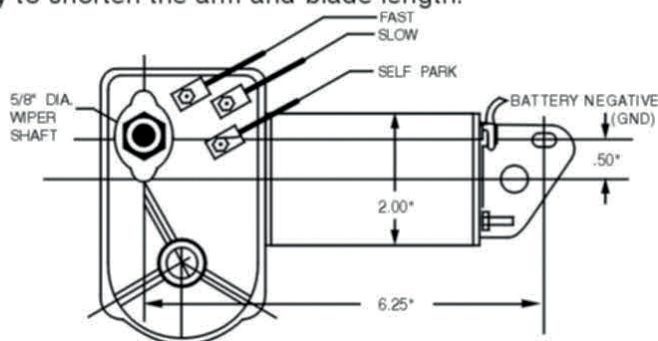

CHANGE WIPING ANGLE & PARKING

Should a change of wiping angle be necessary, it can be performed on follows (see illustration).

- Remove cover plate with a "+" screw driver.
- Using a "-" screw driver to remove "U" shape clip on the shaft connecting transmission plate to the main shaft.
- Lift the transmission plate.
- Unscrew the two screws fastening the angle plate to the white cog wheel. There are two oblong holes in the cog wheel.
- If you want to change the "parking", place the transmission pin in the opposite oblong hole.
- If you want to change the "wiping angle", replace the angle plate-align the hole marked with the desired sweep angle with the oblong hole on cog wheel, and screw the angle plate back.
- Replace transmission plate, replace "U" clip, if much of lubricating grease is removed during the process, replenish some.

