



QUALITY MARINE ACCESSORIES

AFI-1000 & AFI-2000 Heavy-Duty, Waterproof Wiper Motors

AFI-1000 and AFI-2000 Heavy-Duty Waterproof Wiper Motors

The AFI-1000 and AFI-2000 offer the following features:

- Full three-year warranty
- Extra heavy-duty motors and magnets
- Fully sealed waterproof housing
- U.V. stabilized, high impact thermoplastic
- Standard 5/8" diameter, anti-rotation knurled drive shaft and solid brass arm drive nut
- Adjustable self-parking
- AFI-1000 measures 6-5/8" L x 3-3/8" W x 2" H
- AFI-2000 measures 7-3/4" L x 3-7/8" W x 2-3/8" H
- AFI-1000 pulls up to a 16" arm and 16" blade combination
- AFI-2000 pulls up to a 24" arm and 24" blade combination
- AFI-1000 has adjustable sweep settings of 50°, 65°, 80°, and 110°
- AFI-2000 has adjustable sweep settings of 45°, 60°, 80°, and 110°

NOTE: Please Read All Instructions Before Starting

TOOLS NEEDED

- 7/32" Drill Bit For Through
- 5/32" Drill Bit For Self-Hole Mounting
- Drill
- 5/8" Drill Bit (16 mm)
- 1/2" Round File
- 3/4" Open End Box Wrench
- Quick-Connect Tabs
- Marine Grade Caulk Or Silicone
- On/Off Switch
- Phillips Head Screwdriver
- Safety Glasses
- 16 Gauge Wire
- Measuring Tape

MOUNTING PRECAUTIONS

1. Mount wiper motor on a flat surface. Failure to do so may crack the housing when securing.
2. For optimum performance, keep the wiper shaft 90° to the windshield.
3. Blade and arm should be installed approximately 1" (25.4 mm) minimum away from windshield molding. Energize the motor for short intervals to make certain the wiper blade does not strike at either end of the wiping arc. If blade strikes at both ends, it will be necessary to shorten the arm and blade length and/or reduce the sweep angle.

MOUNTING & WIRING

1. Locate proper mounting position of wiper assembly, and determine whether adequate space is available.
2. Drill wiper shaft hole first, using a 5/8" drill. It may be necessary to enlarge the 5/8" hole slightly with a file to facilitate ease of installation.
3. Use motor as a template to drill hole for mounting bracket. A no. 10 size screw is recommended.
4. Before mounting, connect wiring to wiper motor (see diagram).
 - **NOTE:** If the motor is installed in a location exposed to moisture, fill in the wiring cavity with marine grade caulk or silicone after making the electrical connections in order to prevent terminal electrolytic corrosion.
5. The wiper motor may now be placed in position and the wiper shaft attaching nut and washers installed. This nut should be tightened no more than 30 to 45 in-lbs.
6. The mounting bracket screw should be attached at no more than 15 in-lbs. Do not over tighten.

MOUNTING DIAGRAM

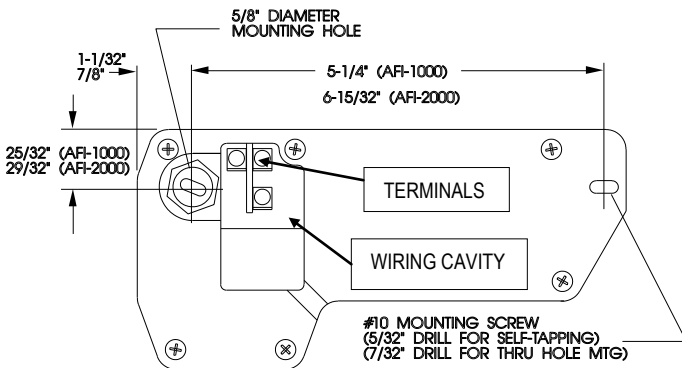

WIRING DIAGRAMS

ONE WIPER TO ONE SWITCH

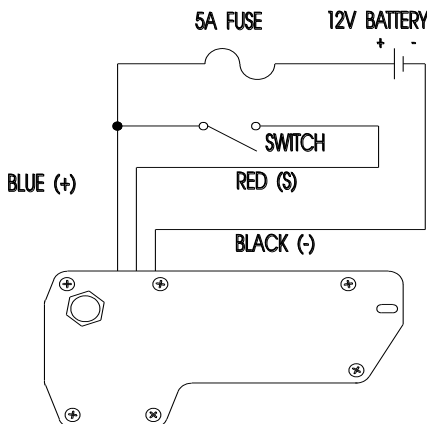

TWO WIPERS TO ONE SWITCH

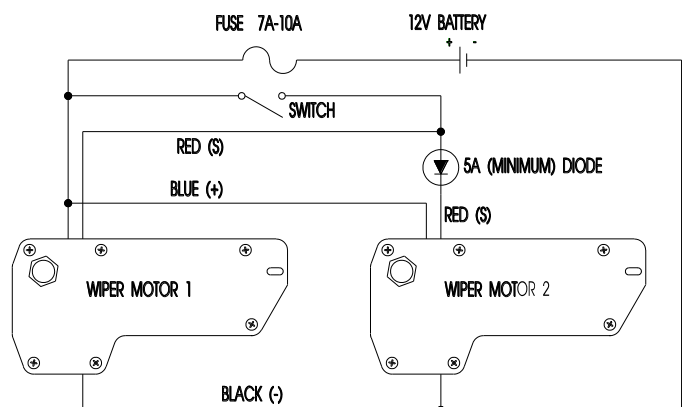

NOTE: MOTOR 2 WILL SELF PARK AFTER MOTOR 1 SELF PARKS.

CHANGING WIPING ANGLE

1. Turn on and then turn off wiper switch and allow wiper to move to parking position.
WARNING: Wiper should automatically park (move to one side or the other) after the wiper is turned off. Failure to do so indicates that the wiper is incorrectly wired. Review wiring diagram.

2. Remove the wiper blade; remove wiper from its mounting position.
3. Remove the wiper motor cover mounting screws (Qty: 6) using a Phillips head screwdriver.

AFI-1000 Angle Choices: 50, 65, 80, and 110 degrees
 AFI-2000 Angle Choices: 45, 60, 80, and 110 degrees

4. Remove the POSITION SCREW from the TRANSMISSION PLATE. Remove the two (2) SWEEP ANGLE SCREWS.

NOTE: Make sure that the SHAFT PLATE keeps in position as shown on drawings below. Do not allow wiper output shaft to rotate 180 degrees out of position (proper position shown on drawings). If wiper output shaft rotates out of position shown on drawing, wiper motor failure will occur.

Rotate SWEEP ANGLE PLATE so that the desired angle hole is in the "6 o'clock" position for right parking or the "12 o'clock" position for left parking (see drawings below).

Reinstall the two (2) SWEEP ANGLE SCREWS.

Reinstall the POSITION SCREW.

Be careful to securely re-tighten ALL SCREWS to prevent accidental loosening (15 in-lbs. maximum).

5. Reinstall wiper motor cover, taking care to snug the mounting screws **without over tightening**. Be sure to tighten screws evenly around cover. Gap between the cover and base should be even all around.

6. After remounting wiper motor, turn on motor and observe operation prior to reinstalling wiper arm. Verify that wiper rotates through the correct number of degrees and parks in the correct position prior to installation of wiper blade. Failure to do this could cause damage to wiper motor.

CHANGING PARKING POSITION

1. Remove the wiper motor cover as described under the section, "Changing The Wiping Angle."
2. Note the current sweep angle inscribed on the angle plate. Remove the POSITION SCREW. Remove the two (2) SWEEP ANGLE SCREWS.
3. Rotate SWEEP ANGLE PLATE 180 degrees.

NOTE: Depending on original parking location (right or left), the "position screw" will be either in the "6 o'clock" position or the "12 o'clock" position. In order to reattach the transmission plate to the original hole, you will need to move the transmission plate to the other end of its travel (see drawings below).

4. Reinstall the two (2) SWEEP ANGLE SCREWS. Reinstall the POSITION SCREW in the same sweep angle hole from which it was removed.

NOTE: Installing the position screw in any other angle hole will cause the parking position to be incorrect. If you wish to make the sweep angle adjustment, see "Changing The Wiping Angle" instructions.

5. Reinstall wiper motor cover as described under the section "Changing The Wiper Angle."

AFI-1000 with 110 deg. Sweep Angle in Right Park Position:

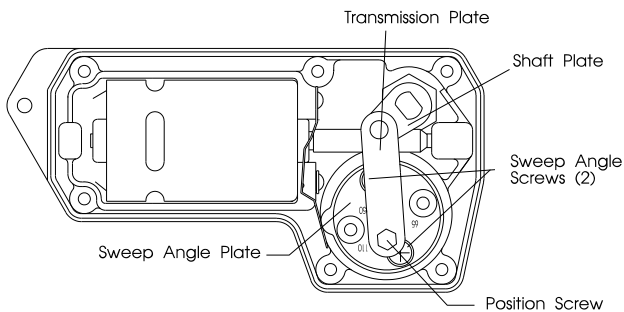

AFI-2000 with 80 deg. Sweep Angle in Right Park Position:

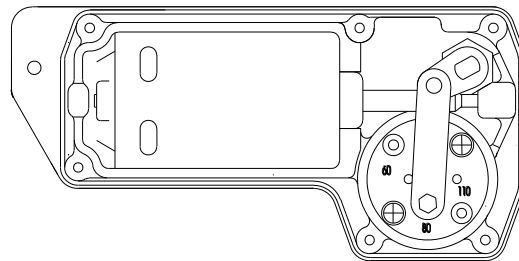

AFI-1000 with 110 deg. Sweep Angle in Left Park Position:

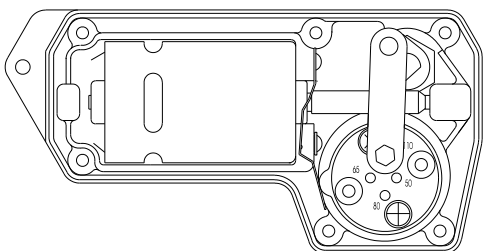

AFI-2000 with 80 deg. Sweep Angle in Left Park Position:

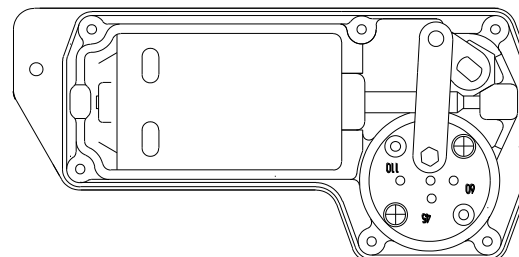

CARE AND MAINTENANCE

Although the AFI-1000 and AFI-2000 are made of U.V. stabilized, chemical resistant thermoplastics, it is recommended to periodically clean them with a mild soap to remove caustic residues.



MARINCO-AFI LIMITED THREE-YEAR WARRANTY

MARINCO-AFI, Inc., provides the following Limited Warranty on its products to the original purchaser of the product and to any person to whom such product is transferred during the duration of this warranty.

The warrantor's obligation shall be limited to the repairing or replacing, at warrantor's election, at the warrantor's address, any part or parts which shall within the THREE YEARS hereinafter specified be returned to it with transportation prepaid and which upon examination by MARINCO-AFI, Inc., shows to have been defective.

The warranty shall NOT apply if the product has been altered, repaired or modified outside the warrantor's place of business in any way that would adversely affect its operations.

The THREE YEAR limited warranty period shall commence with the date the product is sold to the purchaser by the dealer.

The implied warranties or merchantability and fitness for a particular purpose are limited to the duration of this warranty -- three years.

Purchase or other acceptance of this product by the claimant shall be on the condition and agreement that MARINCO-AFI, Inc., SHALL NOT BE LIABLE FOR INCIDENTAL OR CONSEQUENTIAL DAMAGES OF ANY KIND.

Some states do not allow the exclusion of limitation of implied warranties or consequential damages, so the above limitation or exclusions may not apply to you. This warranty gives you specific legal rights, and you may also have other rights that vary from state to state.