



55-2400 Freshwater Steering Kit
55-2600 Saltwater Steering Kit

INSTALLATION INSTRUCTIONS



Typical installation options are shown here. It may be necessary to bend the threaded rod to fit your application

Steering Kit Installation

For Models:

55-2400 [Zinc-Plated for Freshwater]

55-2600 [Stainless Construction for Saltwater]

Attach one ball stud to the front of the kicker motor using the provided brackets. You may have to drill your own holes, be sure there are no electronics to damage before drilling. If unsure, check with the manufacturer or a marine mechanic for recommended mounting locations for the ball stud.

Attach the other ball stud to the main outboard through existing holes in the front, or use the provided 2-piece clamp mount to clamp around the return rod from the steering tube.

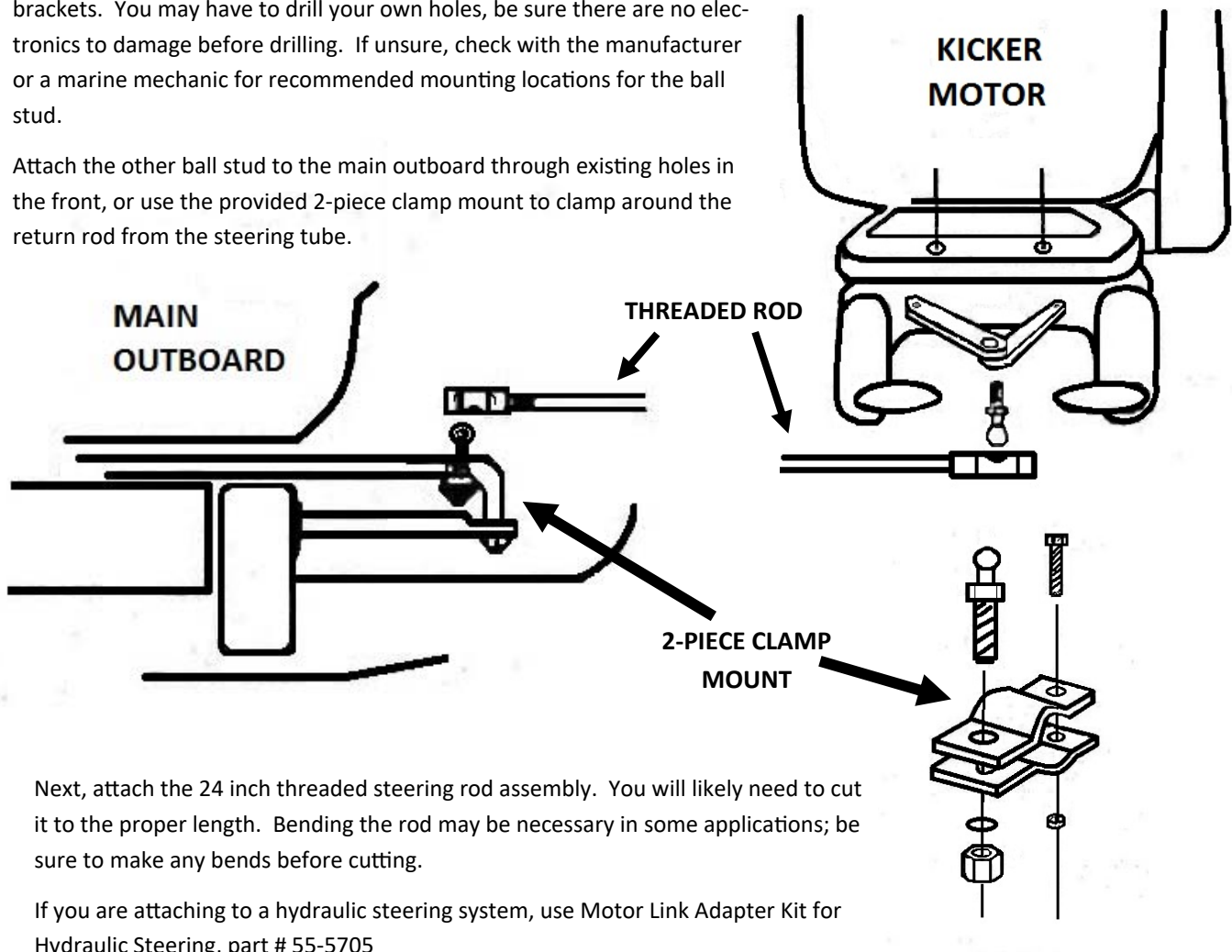

Next, attach the 24 inch threaded steering rod assembly. You will likely need to cut it to the proper length. Bending the rod may be necessary in some applications; be sure to make any bends before cutting.

If you are attaching to a hydraulic steering system, use Motor Link Adapter Kit for Hydraulic Steering, part # 55-5705

If you are trying to use the 55-2400 or 55-2600 to connect your kicker motor to an I/O, difficulties may be encountered. We suggest using an "EZ-Steer" kit instead.