



USERS MANUAL

MASS SINE 12/800 & 24/800

SINE WAVE INVERTER



TABLE OF CONTENTS:

v 5.0 October 2010

1	GENERAL INFORMATION.....	4
1.1	Use of this manual.....	4
1.2	Guarantee specifications.....	4
1.3	Validity of this manual.....	4
1.4	Quality.....	4
1.5	Liability.....	4
1.6	Identification label.....	4
1.7	Changes to the Mass Sine.....	4
2	SAFETY GUIDELINES AND MEASURES.....	5
2.1	Warnings and symbols.....	5
2.2	Use for intended purpose.....	5
2.3	Organizational measures.....	5
2.4	Maintenance & repair.....	5
2.5	General safety and installation precautions.....	5
2.6	Warning regarding life support applications.....	6
2.7	Warning regarding the use of batteries.....	6
3	OPERATION.....	7
3.1	Introduction.....	7
3.2	Switching On and Off.....	7
3.3	Indicators.....	7
3.4	Remote controlled operation.....	8
3.5	Maintenance.....	8
3.6	Problem solving.....	8
4	INSTALLATION.....	9
4.1	Unpacking.....	9
4.2	Environment.....	9
4.3	Wiring.....	9
4.3.1	AC-wiring.....	9
4.3.2	DC wiring.....	10
4.3.3	AC safety grounding.....	10
4.4	Remote monitoring and control.....	10
4.5	Things you need.....	11
4.6	Connection.....	11
4.7	Installation drawing.....	12
4.8	Installation step-by-step.....	13
4.9	Low energy mode.....	14
4.9.1	Low power mode.....	14
4.9.2	Economic mode.....	14
4.9.3	Stand-by mode.....	14
4.10	Commissioning.....	15
4.11	Decommissioning.....	15
4.12	Storage and transportation.....	15
4.13	Re-installation.....	15
5	TROUBLE SHOOTING.....	16
6	TECHNICAL DATA.....	17
6.1	Specifications.....	17
6.2	Dimensions.....	18
7	EC DECLARATION OF CONFORMITY.....	19

1 GENERAL INFORMATION

1.1 USE OF THIS MANUAL

This manual serves as a guideline for the safe and effective operation, maintenance and possible correction of minor malfunctions of the Mass Sine.

It is therefore obligatory that every person who works on or with the Mass Sine must be completely familiar with the contents of this manual, and that he/she carefully follows the instructions contained herein.

Installation of, and work on the Mass Sine, may be carried out only by qualified, authorised and trained personnel, consistent with the locally applicable standards and taking into consideration the safety guidelines and measures (chapter 2 of this manual).

Keep this manual at a secure place!

The English version has 20 pages.

1.2 GUARANTEE SPECIFICATIONS

Mastervolt guarantees that this unit has been built according to the legally applicable standards and specifications. Should work take place, which is not in accordance with the guidelines, instructions and specifications contained in this users manual, then damage may occur and/or the unit may not fulfil its specifications. All of these matters may mean that the guarantee becomes invalid.

The guarantee is limited to the costs of repair and/or replacement of the product. Costs for installation labor or shipping of the defective parts are not covered by this guarantee.

1.3 VALIDITY OF THIS MANUAL

Copyright © 2010 Mastervolt. All rights reserved.

Reproduction, transfer, distribution or storage of part or all of the contents in this document in any form without the prior written permission of Mastervolt is prohibited.

All of the specifications, provisions and instructions contained in this manual apply solely to standard versions of the Mass Sine delivered by Mastervolt.

This manual is only valid for the following models:

Description	Part number
Mass Sine 12/800-230V	24010800
Mass Sine 24/800-230V	24020800

1.4 QUALITY

During their production and prior to their delivery, all of our units are tested and inspected. The standard guarantee period is two years after date of purchase.

1.5 LIABILITY

Mastervolt can accept no liability for:

- consequential damage due to use of the Mass Sine;
- possible errors in the manuals and the results thereof.

1.6 IDENTIFICATION LABEL

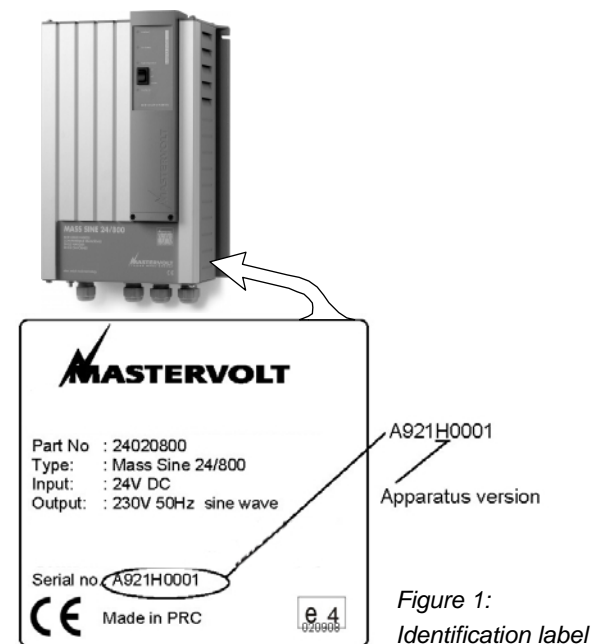

Figure 1:
Identification label

The identification label is located at the right-hand side of the Mass Sine. (see figure 1) Important technical information required for service, maintenance & secondary delivery of parts can be derived from the identification label.



CAUTION!

Never remove the identification label.

1.7 CHANGES TO THE MASS SINE

Changes to the Mass Sine may be carried out only after obtaining the written permission of Mastervolt.

2 SAFETY GUIDELINES AND MEASURES

2.1 WARNINGS AND SYMBOLS

Safety instructions and warnings are marked in this manual by the following pictograms:



A procedure, circumstance, etc which deserves extra attention.



CAUTION!

Special data, restrictions and rules with regard to preventing damage.



WARNING

A WARNING refers to possible injury to the user or significant material damage to the charger if the user does not (carefully) follow the procedures.

2.2 USE FOR INTENDED PURPOSE

- 1 The Mass Sine is constructed as per the applicable safety-technical guidelines.
- 2 Use the Mass Sine only:
 - for the conversion of a DC voltage from a battery to an AC voltage.
 - with a fuse, protecting the wiring between Mass Sine and battery;
 - in a technical correct condition;
 - in a closed, well-ventilated room, protected against rain, moist, dust and condensation;
 - observing the instructions in the users manual.



WARNING

Never use the Mass Sine in situations where there is danger of gas or dust explosion or potentially flammable products!

- 3 Use of the Mass Sine other than mentioned in point 2 is not considered to be consistent with the intended purpose. Mastervolt is not liable for any damage resulting from the above.

2.3 ORGANIZATIONAL MEASURES

The user must always:

- have access to the user's manual;
- be familiar with the contents of this manual. This applies in particular to chapter 2, Safety Guidelines and Measures.

2.4 MAINTENANCE & REPAIR

- 1 If the Mass Sine is switched off during maintenance and/or repair activities, it should be secured against unexpected and unintentional switching on:
 - remove the connection to the batteries
 - be sure that third parties cannot reverse the measures taken.
- 2 If maintenance and repairs are required, use only original spare parts.

2.5 GENERAL SAFETY AND INSTALLATION PRECAUTIONS

- Do not expose the Mass Sine to rain, snow, spray, moisture, excessive pollution and condensing circumstances. To reduce risk of fire hazard, do not cover or obstruct the ventilation openings. Do not install the Mass Sine in a non-ventilated area, overheating may result.
- The Mass Sine must be provided with an equipment-grounding conductor to the AC-output ground terminal. Grounding and all other wiring must comply with local codes and ordinances.
- In case of fire, you must use the fire extinguisher which is appropriate for electrical equipment.
- Short circuiting or reversing polarity will lead to serious damage to batteries, Mass Sine and the wiring. Fuses between the batteries and the Mass Sine can not prevent damage caused by reversed polarity and the warranty will be void.
- Protect the DC wiring with a fuse, according to the guidelines in this manual.
- Connection and protection must be done in accordance with local standards.
- Do not work on the Mass Sine or system if it is still connected to a power source. Only allow changes in your electrical system to be carried out by qualified electricians.
- Check the wiring and connections at least once a year. Defects such as loose connections, burned cables etc. must be corrected immediately.
- Do not touch the equipment when wet or if your hands are clammy.

- Not only the batteries, but the Mass Sine as well can become a projectile if your transport is involved in an accident! Ensure adequate and secure mounting and always use suitable handling equipment for transportation.
- Except for the connection compartment, the cabinet of the Mass Sine must not be opened. There are no serviceable parts inside the cabinet. Only qualified, authorized and trained electrician installers are authorized to open the connection compartment.
- Do not connect the AC output of the inverter to an incoming AC source or generator.

2.6 WARNING REGARDING LIFE SUPPORT APPLICATIONS

The Mass Sine products are not sold for applications in any medical equipment intended for use as a component of any life support system unless a specific written agreement pertaining to such intended use is executed between the manufacturer and Mastervolt. Such agreement will require the equipment manufacturer either to contract additional reliability testing of the Mass Sine parts and/or to commit to undertake such testing as a part of the manufacturing process. In addition the manufacturer must agree to indemnify and not hold Mastervolt responsible for any claims arising from the use of the Mass Sine parts in the life support equipment.

2.7 WARNING REGARDING THE USE OF BATTERIES.

Excessive battery discharge and/or high charging voltages can cause serious damage to batteries. Do not exceed the recommended limits of discharge level of your batteries. Avoid short circuiting batteries, as this may result in explosion and fire hazard. Installation of the batteries and adjustments of the Mass Sine should only be undertaken by authorised personnel!

3 OPERATION

3.1 INTRODUCTION

The Mass Sine is a fully automatic inverter. It converts a DC voltage to a pure AC sine wave voltage. Under normal circumstances there is no need for adjustment or operation besides switching on and off.



WARNING

Never disconnect any of the wiring during operation of the Mass Sine

3.2 SWITCHING ON AND OFF

Switching on: Move main switch on the front of the Mass Sine to the "on" position. The green "inverter on" indicator illuminates and the Mass Sine will start.

Switching off: Move the main switch on front of the inverter to the "off" position. The Mass Sine stops and all the indicators that are on, go off.



WARNING

Switching off the Mass Sine with the main switch on the front of the cabinet does not cut off the connection to the batteries

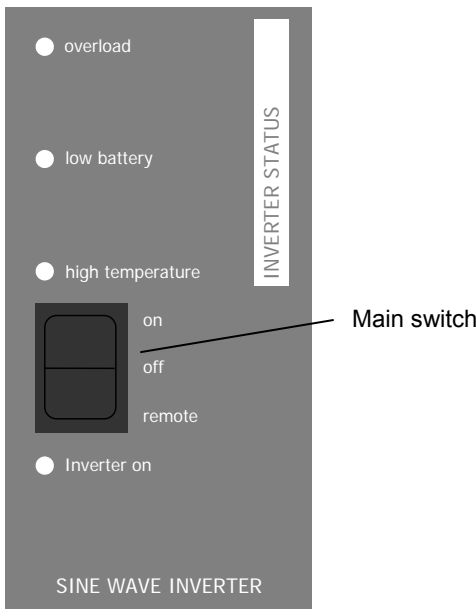

Figure 2: Indicators and main switch

3.3 INDICATORS

See figure 2. The operation of the Mass Sine is displayed by means of LED indicators at the front side of the housing. If the Mass Sine is activated and as long as none of the red indicators are illuminated, no failure is detected and the unit is operating normally.

The functions of the indicator lights on the front are:

inverter on:	Mass Sine is switched on
overload:	Mass Sine is overloaded
overload + inverter on blinking slow:	Overload in 'wait' state
overload + inverter on blinking fast:	The Mass Sine is switched off due to overload
low battery:	battery voltage is too low
high temperature:	Mass Sine is overheated

Short description:

“inverter on”

The green light shows when the Mass Sine is switched on.

“overload”

Glows if the inverter is overloaded. Depending on the load, the Mass Sine will shut down after a short period.

“overload” + “inverter on”

The indicator lights “overload” and “inverter on” will flash in turn if the Mass Sine has been switched off because of an overload condition. The Mass Sine stays off for 1.5 min. Then the Mass Sine will restart automatically. If the overload situation repeats itself 10 times within a period of 5 minutes, then the Mass Sine will not restart automatically. You can restart the Mass Sine only by switching the unit manually off and on with the main switch on the Mass Sine after the overload is removed or failure is solved.

“low battery”

The Mass Sine is switched off if the battery voltage is too low (see table hereunder). If the voltage rises above the values given below, the Mass Sine restarts automatically.

Input voltage	12 Volt	24 Volt
Shut off voltage	10V ±0.5V	19V ±0.5V
Restart voltage	11V ±0.5V	22V ±0.5V

“high temperature”

The Mass Sine switches off in case of high ambient temperatures and /or sustained overload. The Mass Sine is automatically powered up again when the temperature drops below the factory default threshold.

Overheating is most likely caused by:

- heavy or non-resistive loads operating for a longer time
- high ambient temperature
- disrupted air flow (dust or too less space)

3.4 REMOTE CONTROLLED OPERATION

If you use a remote control panel or interface (see section 4.4), the main switch on front of the Mass Sine must be set to the ‘remote’ position. Move the main switch on the remote control panel / interface to the ‘on’ position to switch on the Mass Sine.



NOTE! When the main switch is in the “Off”-position, it overrides the remote control panel / interface. In this off state it is not possible to start the Mass Sine remotely.

The meaning of the illuminated LED’s of the C4 RI panel is:

inverter on:	Mass Sine is switched on
failure:	Mass Sine is overloaded, overheated or battery voltage is too low

If the failure LED is lit you can check the nature of the failure on the inverter front.

Refer to the applicable user’s manual for operation of the other remote control panels or interfaces

3.5 MAINTENANCE

For a reliable and optimum function of the Mass Sine, the following is required:

- Check at least once a year if all cable and wire connections are still firmly connected.
- Keep the inverter dry, clean and dust-free, in order to ensure good heat discharge.
- Check the fan operation (has a life time of at least 10 years in normal use).

3.6 PROBLEM SOLVING

Refer to chapter 5 if a problem occurs.

4 INSTALLATION

During installation and commissioning of the Mass Sine, the Safety Guidelines & Measures are applicable at all times. See chapter 2 of this manual.

4.1 UNPACKING

The delivery consists of the following parts:

- The Mass Sine inverter
- This user's manual

After unpacking, check the contents for possible damage. Do not use the product if it is damaged. If in doubt, contact your supplier.

Check from the identification label (see section 1.6) whether the battery voltage is the same as the DC-input voltage of the Mass Sine (e.g. 24V battery set for a 24V input voltage). Also check that the AC output voltage and output power of the Mass Sine satisfies loading requirements.

4.2 ENVIRONMENT

Obey the following stipulations during installation:

- The Mass Sine is designed for indoor use only.
- Ambient temperature: 0 ... 60°C / 32°F ... 140°F; (power derating above 25°C / 104°F to decrease the internal heat sink temperature)
- Humidity: 0-95% non condensing
- Mount the Mass Sine on a solid surface, with the connecting cables downwards.
- Make sure that the hot air produced during operation can be discharged. The Mass Sine must be mounted in such a way that obstruction of the airflow through the ventilation openings will be prevented.
- No objects must be located within a distance of 10 cm / 4 inch around the Mass Sine.
- Do not locate the Mass Sine in the same compartment as the batteries.
- Do not install the Mass Sine straight above the batteries because of possible corrosive sulphur fumes

4.3 WIRING

The wiring is connected inside the connection compartment. If necessary, the wiring can be fed from the top to the bottom side of the cabinet along the back of the cabinet.

Always feed the wiring through the cable glands of the cabinet, and then connect the wiring to the terminals. Fix the phase line wire to terminal L, the neutral wire to terminal N and the ground wire to terminal PE.

4.3.1 AC-wiring

For a safe installation the correct wire cross section must be applied. Don't use a cross section that is smaller than indicated. See table below to select the appropriate cross section for the AC wiring (up to 6m / 20ft length):

Model Mass Sine	Minimum cross section:	
12/800, 24/800	1.5 mm ²	AWG 14

Recommended wire colours (refer to local rules):

- 230V AC installations:

Wire color	Meaning	Must be connected to:
Brown or black	Phase	L1
Blue	Neutral	N
Green/Yellow	Earth	PE / GND

Recommended torques AC wiring:

Model Mass Sine	Recommended torque AC wiring:	
	Nm	In-Lbs
12/800, 24/800	1.5 – 1.8 Nm	13 – 16 In-Lbs

4.3.2 DC wiring

Keep in mind that high current will pass through the DC wiring. Keep the cable length as short as possible, this will keep the system efficiency as high as possible. See chapter 6 Specifications for recommended DC wire sizes. Use cable lugs terminals on the ends of the wires. These lugs should be crimped with a proper crimping tool. Use the following wire colours for DC wiring (refer to local rules):

Wire color	Meaning	Must be connected to:
Red	Positive	+ (POS)
Black	Negative	- (NEG)

Lay the positive and negative cables next to each other to limit the electro magnetic field around the cables. The negative cable should be connected directly to the negative post of the battery bank or the ground side of a current shunt. Do not use the chassis frame or hull of the ship as the negative conductor. Tighten connections securely.

Recommended torques DC wiring:

Model Mass Sine	Recommended torque DC wiring:	
	Nm	In-Lbs
12/800, 24/800	7.4 - 8.4 Nm	65 - 74 In-Lbs

The positive battery cable must be fused according to local applicable regulations and connected to the positive post of the battery bank.

See chapter 6 Specifications for recommended fuses.

The fuse with the fuse-holder is available from your local Mastervolt distributor or Customer Service Representative.

4.3.3 AC safety grounding



WARNING

The ground wire offers protection only if the cabinet of the Mass Sine is connected to the safety ground. Connect the earth terminal (PE / GND) to the hull or the chassis.



CAUTION!

For safe installation it is necessary to:

- connect the neutral conductor (N) of the AC output to the earth (PE / GND);
- insert a Residual Current Device (earth leakage switch) of 30mA in AC output of the Mass Sine.

Refer to local regulations on these issues!

4.4 REMOTE MONITORING AND CONTROL

Mastervolt offers several possibilities for remote monitoring and control of the Mass Sine:

- The *R-4-RI panel*
- The *Mass Inverter Charger Control (MICC)*
- The *Masterbus – Inverter Interface*
- The *Masterbus – AC Power Analyser*

The *R-4-RI panel* provides the same functions as the user panel on the Mass Sine. However, with this remote panel you have the convenience to operate the Mass Sine remotely. This panel is suitable for *MasterVision*, Mastervolt’s modular switchboard system.

The *Masterlink MICC panel* (art. no) is a digital remote panel that has additional features compared to the *R-4-RI panel*. This sophisticated panel is not only a remote control panel to switch on and off your Mass Sine but also a battery consumption meter for read-out of the exact state-of-charge of your battery by means of a shunt. (included with the delivery of the *Masterlink MICC*) When the battery is reaching a low voltage set point or a low state-of-charge an alarm can be raised.

The information provided includes reading voltage, current, consumed Ah, time remaining and remaining capacity as a percentage of the maximum available battery capacity.

With the *MasterBus – Inverter interface* you can connect your Mass Sine to the *MasterBus* network: a fully decentralized data network for communication between the different Mastervolt system devices such as the inverter, battery charger, generator, batteries and many more.

The *AC Power Analyser* has additional features compared to the *MasterBus – Inverter* interface:

- Exact status overview of the Mass Sine: voltage, current, load and frequency.
- Users setting of amperage and overload control.
- Power consumed as percentage of the total available power.
- Alarm functions for low/high voltage, frequency, and overload.
- Automated preference load operation.

The remote panels and the MasterBus –interfaces can be connected to the “REMOTE”-connection; see figure 3 via a modular communication cable with two RJ 12 connectors. Refer to the applicable installation manual for instructions. The maximum length of communication cable should not exceed 15m/49ft. Note that it is not possible to connect several panels and MasterBus interfaces at the same time.

See chapter 5 for ordering information

4.5 THINGS YOU NEED

Make sure you have all the parts you need to install the Mass Sine:

- Mass Sine (included)
- DC-cable (see section 4.3.2 for specifications)
- AC cable (see section 4.3.1 for specifications)
- DC-fuse holder with a DC-fuse, to be integrated in the positive DC-cable. For specifications see chapter 6
- Screws / bolts (Ø 5mm) (with plugs) to mount the cabinet to a surface. Use mounting materials which are suitable to carry the weight of the Mass Sine
- Batteries. Refer to chapter 6 Specifications for recommended capacity
- Appropriate and reliable cable terminals, cable lugs, battery terminals and cord end terminals

We recommend as a minimum tool kit:

- Socket wrench 10mm to fix the DC-input (battery) cables
- Flat blade screw driver 1.0 x 4.0 mm to fix the screw terminals
- Tools to fix the screws / bolts with plugs to mount the cabinets to a surface
- Philips screw driver to open the connection area of the Mass Sine

4.6 CONNECTION



WARNING

Let installation work be done by a licensed electrician. Before beginning with the connection of the wiring, make the DC distribution voltage free. Move the main switch (see figure 2) to the “Off”-position.



CAUTION!

Short circuiting or reversing polarity may lead to serious damage to the batteries, the Mass Sine, the wiring and/or the terminal connections. Fuses between the batteries and the Mass Sine can not prevent damage caused by reversed polarity. The damage as a result of reverse polarity is not covered by the warranty.



CAUTION!

Too-thin cables and/or loose connections can cause dangerous overheating of the cables and/or terminals. Therefore tighten all connections well, in order to limit transition resistance as far as possible. Use cables of the correct size



NOTE!

Feed the cables through the cable glands of the cabinet before you fix the cable lugs to the wire ends.

4.7 INSTALLATION DRAWING

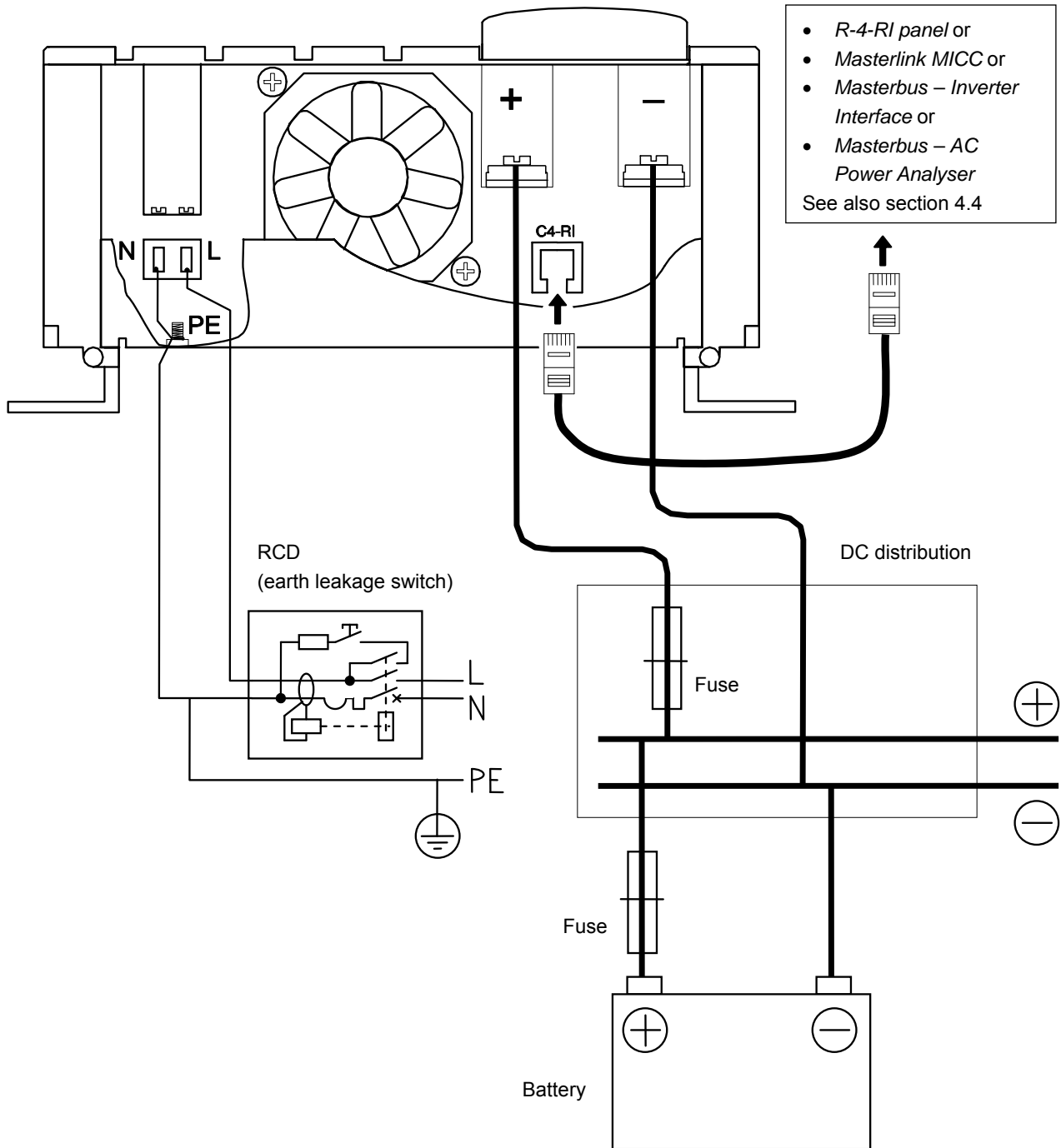

This schematic is to illustrate the general placement of the Mass Sine in a circuit. It is not meant to provide detailed wiring instructions for any particular electrical installation.

Figure 3: Installation drawing of the Mass Sine inverter

4.8 INSTALLATION STEP-BY-STEP

1 Move the main switch on front of the inverter to the "off" position.

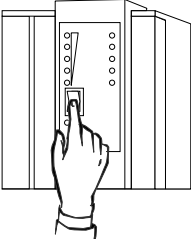

2 Disconnect the electrical power:

- Switch off all consumers,
- Switch off all charging systems.
- Remove the battery fuse.
- Check with a suitable voltmeter whether the DC installation is voltage free.

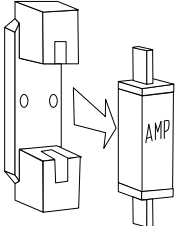

3 Use four bolts (not included) to mount the inverter vertically on a solid wall. Allow at least 10 cm / 4 inch space around the apparatus!

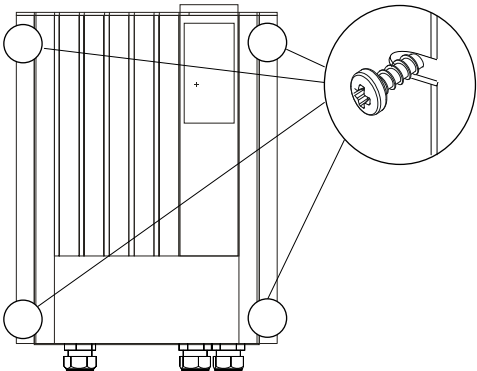

4 Open the connection compartment; Steps:

- 1 Loosen the two Philips screws that secure the front cover plate for two turns.
- 2 Slide the front cover plate from the cabinet

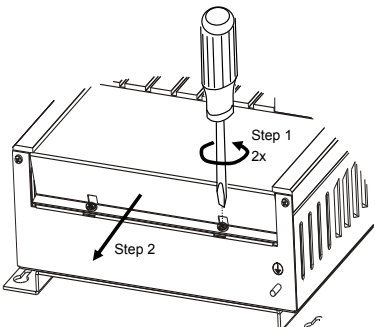

5 Connect the AC load to the AC output.

For safe installation it is necessary to:

- Connect both the earth (PE/GND) and the neutral (N) of the AC output of the inverter to the central grounding point
- Integrate a Residual Current Device (RCD) in wiring of the AC output

Refer to local applicable regulations on these issues.

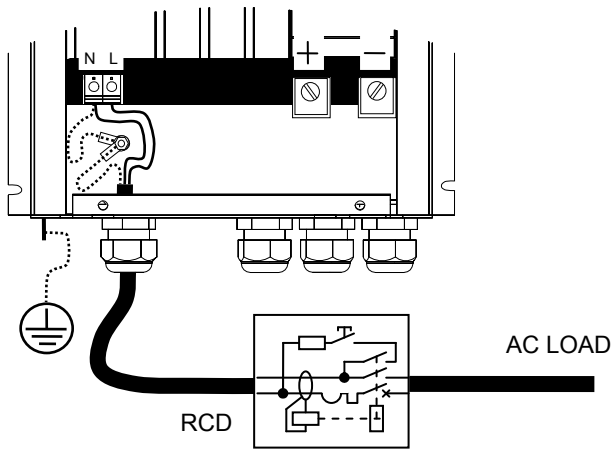

6 Connect the battery to the DC input.

Integrate a fuse holder in the positive battery wire, but do not place the fuse yet.

Connect positive wire to +, negative wire to -.

Incorrect polarity will damage the inverter!

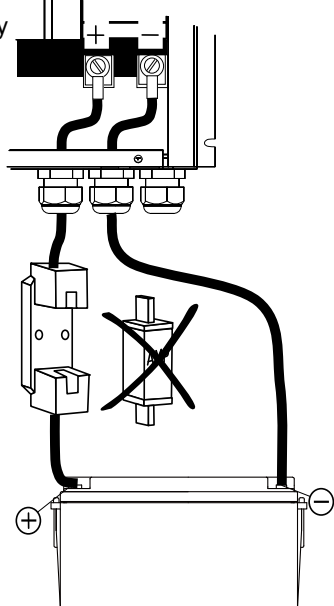

7 Continue with sections 4.9 and 4.10.

4.9 LOW ENERGY MODE

For applications that require a very low energy mode, it is possible to set the inverter into “low energy mode”. The “low energy mode” can be selected by placing a jumper (green) on the two metal pins on the top (left) corner of the PCB (see figure 4).

To change the jumper settings, act as follows:

- 1 Demount the inverter from the wall.
- 2 Loosen the four corner screws from the top cover.
- 3 Remove the top cover from beneath the green plastic.
- 4 The jumpers S1 and S2 are visible now.
- 5 Set the jumpers to the desired state (see table below).
- 6 Place the top cover again and tighten the four corner screws.

Low energy mode settings:

S1	S2	mode	output voltage
0	0	standard	230V
0	1	low power	208V < 30W
1	0	economic	208V < 250W
1	1	stand-by	0V, si attiva in caso di carico

4.9.1 Low power mode

In this mode the output voltage will drop to 208V if the connected load stays below 30W. The output voltage will be ± 230V again if the connected load rises above 30W. Small loads like a digital clock will function properly and still 10% energy can be saved. The inverter can be set in this mode by placing jumper S2. Do not place jumper S1.

4.9.2 Economic mode

In this mode the output voltage will drop to 208V if the connected load stays below 250W. The output voltage will be ± 230V again if the connected load rises above 250W. Most loads will function properly and still 10% energy can be saved. The inverter can be set in this mode by placing jumper S1. Do not place jumper S2

4.9.3 Stand-by mode

The inverter has now been set to stand by mode, there will be no output voltage. The inverter checks if there is a load connected and will switch on when a load is detected. This mode will reduce the no load consumption with 90%. This mode is especially use-full when mostly heave loads are connected to the inverter. Loads with digital clocks can function irregularly, if this is the case set the inverter to economic or low power mode. The inverter can be set in this mode by placing jumper S1 and S2.



NOTE:

Adjust the settings prior to commissioning!

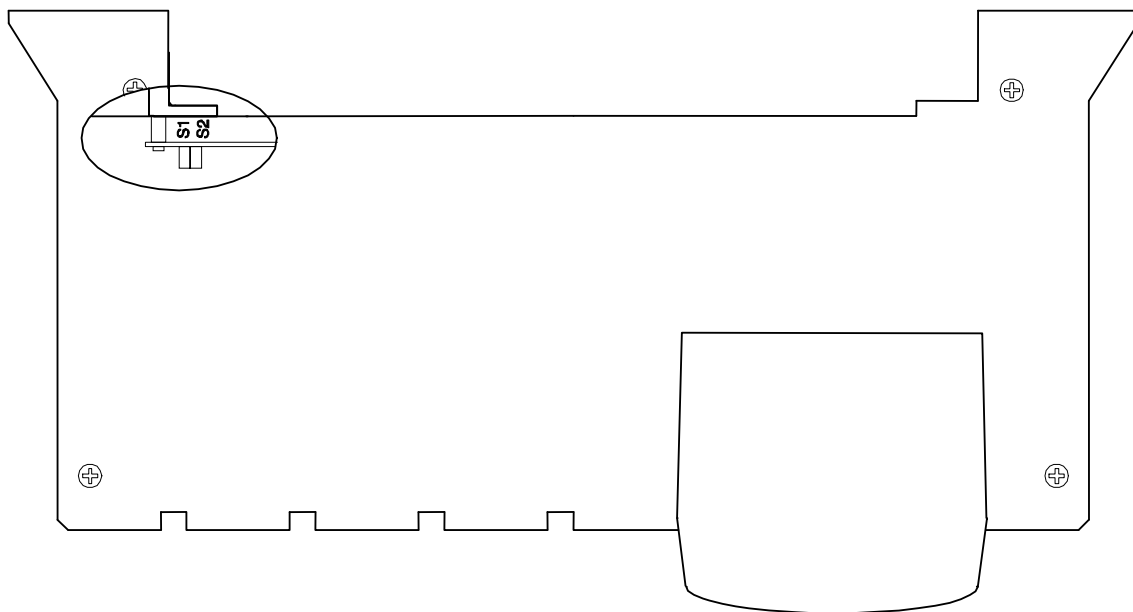

Figure 4: Top view of the inverter and position of the jumpers

4.10 COMMISSIONING

**CAUTION!**

Check the polarity of all wiring before commissioning: plus connected to plus (red cables), minus connected to minus (black cables)

Follow the steps described below to switch on the Mass Sine.

- 1 Tighten all cable glands to ensure the pull relief
- 2 Check all wiring and connections
- 3 Close the front cover plate of the connection compartment of the Mass Sine. Beware that the wiring does not obstruct the cooling fans and air flow.
- 4 Place the DC-fuse(s) of the DC-distribution to connect the batteries to the Mass Sine.

**WARNING**

When placing this fuse, a spark can occur, caused by the capacitors used in the Mass Sine. This is particularly dangerous in places with insufficient ventilation, due to the gassing of the batteries an explosion can occur and avoid having flammable materials close by.

Now the Mass Sine is ready for operation.

4.11 DECOMMISSIONING

If it is necessary to put the Mass Sine out of operation, follow the instructions in order of succession as described below:

- 1 Move the Main-switch of the Mass Sine to the "Off"-position (see figure 2).
- 2 Remove the DC-fuse(s) of the DC-distribution and/or disconnect the batteries.
- 3 Open the connection compartment of the Mass Sine
- 4 Check with a suitable voltage meter whether the inputs and the outputs of the Mass Sine are voltage free.
- 5 Disconnect all the wiring

Now the Mass Sine can be demounted in a safe way.

4.12 STORAGE AND TRANSPORTATION

When not installed, store the Mass Sine in the original packing, in a dry and dust free environment.

Always use the original packing for transportation. Contact your local Mastervolt Service Centre for further details if you want to return the apparatus for repair.

4.13 RE-INSTALLATION

To reinstall the Mass Sine, follow the instructions as described in this chapter (chapter 4).

5 TROUBLE SHOOTING

If you cannot solve a problem with the aid of this table, contact your local Mastervolt Service Centre. Make sure you have the following information present if you have to contact your local Mastervolt Service Center to solve a problem: Article and serial number (see section 1.6)

Malfunction	Possible cause	What to do
No output voltage and no indication lights (LED's are off)	High battery voltage	Check battery voltage and switch off the charger
	DC fuse blown	Replace the fuse.
	Main switch set to remote, but no remote present	Move main switch to the On position.
No output voltage, LED "low battery" is lit	Flat battery	Charge the batteries, the inverter will switch on if the battery voltage is above 11.0/22.0V (see section 3.3).
No output voltage and LED "high temperature" is lit.	The inverter has been overloaded	Reduce the load and let the inverter cool down.
No output voltage and LED "inverter on" is lit	The inverter is in stand by mode	Connect a load or change the jumper settings (see section 4.9.23).
Low output voltage	Jumper setting = Low power mode / Economic mode	Connect a load > 30W / >250W or change jumper settings (see section 4.9.1 / 4.9.2).
Inverter goes on and off, LED "inverter on" and LED "low battery" are blinking on turns	Flat battery	Disconnect load and charge batteries.
	DC cables too thin	Replace with cables of correct diameter.
	Connections are corroded or bad	Tighten the connections. If the cables are burned, replace them.
Inverter goes on and off, LED "inverter on" and "overload" blink in turns one time per second, ventilator is running at full speed	Inverter is overloaded	Reduce the load on the inverter
Inverter goes on and off, LED "inverter on" and "overload" blink in turns five times per second, ventilator is running at full speed.	Inverter has been switched off ten times as a result of an overload situation	Reduce the load. Reset the inverter manually by means of the main switch.

ORDERING INFORMATION

Part number	Description
70404110	Panel C-4-RI Remote, control panel for Mastervolt inverters (see section 4.4)
70403105	Masterlink MICC panel (see section 4.4)
6502001030	Modular communication cable, cross wired, 6 pole, 6 meter
6502100100	Modular communication cable, cross wired, 6 pole, 10 meter
77030700	MasterBus Inverter Interface (see section 4.4)
77031200	MasterBus AC power analyser (see section 4.4)
6385401610	RCD (residual current device) for DIN rail mounting 16Amp/B/30mA, 1P+N

Mastervolt can offer a wide range of products for your electrical installation, including automatic AC transfer switches, remote control panels and shore cable connection sets

6 TECHNICAL DATA

6.1 SPECIFICATIONS

Model Mass Sine	12/800 - 230V	24/800 - 230V
Part number	24010800	24020800
Function of the apparatus:	Conversion of a DC voltage to a pure AC sine wave voltage	
Manufacturer:	Mastervolt, Amsterdam, The Netherlands	
DC input		
	12/800 - 230V	24/800 - 230V
Nominal battery voltage	12V	24V
Absolute maximum voltage range (no defects)	0.0 – 16.0 V	0.0 – 35.0 V
Low battery switch off (1-30 sec delay)	10.0V ±0.5V	19.0V ±0.5V
Low battery switch on	11.0V ±0.5V	22.0V ±0.5V
High battery switch off (No delay)	16.0V ±0.5V	33.0V ±0.5V
High battery switch on	15.5V ±0.5V	31.0V ±0.5V
Max. ripple allowed on DC (No defects)	5 % RMS	5 % RMS
Input current at nominal load	68A	34A
Wire size (up to 2m/6ft)	2x 25mm ² / AWG 3	2x 16mm ² / AWG5
Recommended fuse	100A	63A
Recommended batteries	>100Ah	>50Ah
DC No load power consumption		
Stand-by mode	65mA/0.8W	35mA/0.8W
Low power mode / Economic mode	410mA/4.9W	200mA/4.9W
High power mode	470mA/5.6W	240mA/5.6W
AC output		
Nominal voltage (±5%)	230VAC	230VAC
Wave form	True sine wave, max 5% distortion, 3% typical	
Frequency	50Hz +/- 0.1%	50Hz +/- 0.1%
P30 power @ T-amb=25°C/77°F, cosφ=1	800VA	800VA
Nominal power @ T-amb=40°C/104°F, cosφ=1	650VA	650VA
Peak power	1600VA	1600VA
Cos φ	All power factors allowed	
Max. efficiency	92%	92%
Environmental Specifications		
Operating temperature range	SPECIFIED, will meet specified tolerances. 0°C to 25 °C / 32 to 77°F	
	ALLOWED, may not meet specified tolerances. -25°C to 60°C / -13 to 140°F	
	NON-OPERATING, storage. -25°C to 85°C / -13 to 185°F	
Humidity	Max 95% relative humidity, not condensing.	
Protection degree	IP 23	
Cooling	Mix of conventional and forced air cooling, by DC fans with variable speed.	
Enclosure		
Type	C1	C1
Dimensions hxwx d in mm	325 x 220 x 111 mm / 12.8 x 8.7 x 4.4 inch	325 x 220 x 111 mm / 12.8 x 8.7 x 4.4 inch
Weight	3.9 kg / 8.6 Lbs	3.9 kg / 8.6 Lbs

6.2 DIMENSIONS

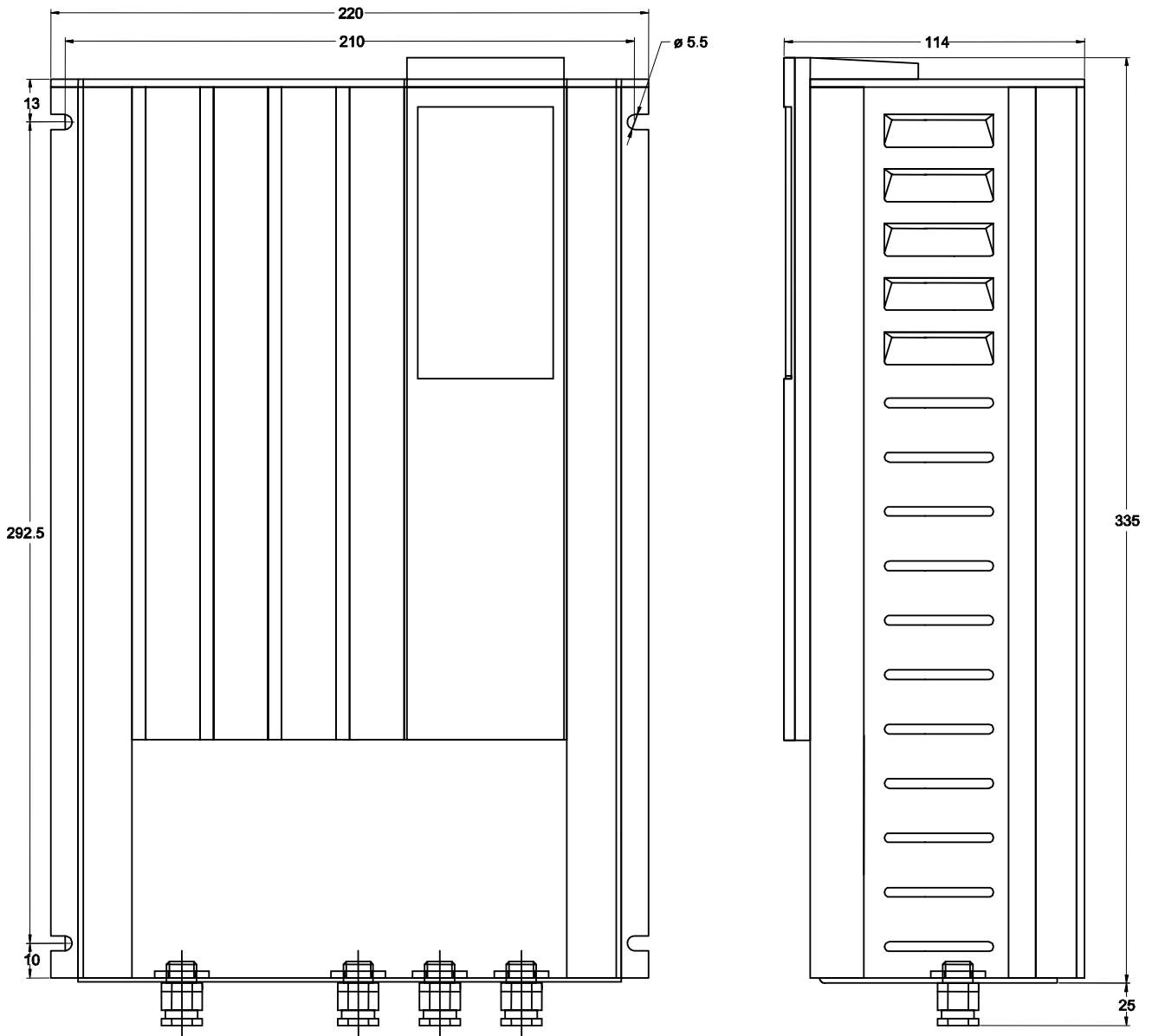

Figure 5: Dimensions Mass Sine 12/800 - 230V and 24/800 - 230V

7 EC DECLARATION OF CONFORMITY

We,

Manufacturer Mastervolt
Address Snijdersbergweg 93
 1105 AN Amsterdam
 The Netherlands



Declare under our sole responsibility that
Product:

24010800 Mass Sine 12/800-230V
24020800 Mass Sine 24/800-230V

Is in conformity with the provisions of the following EC directives:

- 2004/108/EC (EMC directive); the following harmonized standards have been applied:
 - EN 61000-6-3: 2007 Emission household equipment
 - EN 61000-6-2: 2007 Immunity industrial

- 2006/95/EC (Safety directive); the following harmonized standard has been applied:
 - EN 60950-1:2001+ A11:2004 (Low voltage standard)

Amsterdam,



H.A. Poppelier
Product Manager Marine & Mobile
Mastervolt