



# COMBIMASTER

**120V Series**

INVERTER CHARGER COMBINATION  
WITH AC-IN SUPPORT



USER AND INSTALLATION MANUAL

10000015714/06

## TABLE OF CONTENTS

<b>1 SAFETY INSTRUCTIONS</b> .....	<b>3</b>	4.8.1 Remote switch .....	17
1.1 General .....	3	4.8.2 Alarm output .....	17
1.2 Warnings regarding the use of batteries .	4	4.9 System integration (CZone/MasterBus)	18
1.3 Location.....	5	<b>5 SETTINGS</b> .....	<b>19</b>
1.4 Connections .....	5	5.1 DIP switch settings.....	19
1.5 Warning regarding life support applications .....	5	5.2 MasterBus configuration .....	20
<b>2 GENERAL INFORMATION</b> .....	<b>6</b>	5.2.1 Monitoring.....	20
2.1 Liability .....	6	5.2.2 Alarms .....	20
2.2 Warranty.....	6	5.2.3 History .....	21
2.3 Identification label.....	6	5.2.4 Configuration Settings .....	21
2.4 Correct disposal of this product .....	6	5.2.5 Events – System automation .....	22
<b>3 PRODUCT DESCRIPTION</b> .....	<b>7</b>	5.3 CZone configuration.....	23
3.1 Overview of the connections.....	7	<b>6 OPERATION</b> .....	<b>26</b>
3.2 Operating modes.....	7	6.1 Switching On / Charge only.....	26
3.3 Remote control .....	9	6.2 Status LEDs.....	26
3.4 Protection .....	9	6.3 3-step+ charge process .....	27
<b>4 INSTALLATION</b> .....	<b>10</b>	6.4 Temperature compensated charging ....	28
4.1 Unpacking .....	10	6.5 Reset the thermal fuse after an overload.....	28
4.2 Location.....	10	6.6 Maintenance .....	29
4.3 Batteries .....	11	6.6.1 Decommissioning .....	29
4.4 Connection example.....	11	6.6.2 Storage and transportation .....	29
4.5 Wiring .....	12	<b>7 TROUBLESHOOTING</b> .....	<b>30</b>
4.5.1 DC wiring .....	12	<b>8 TECHNICAL DATA</b> .....	<b>32</b>
4.5.2 AC wiring.....	12	8.1 Inverter specifications .....	32
4.5.3 AC Safety grounding .....	13	8.2 Charger specifications .....	33
4.5.4 Network wiring (CZone/MasterBus)....	13	8.3 Transfer system specifications .....	34
4.6 Things you need.....	13	8.4 Miscellaneous .....	34
4.7 Installation step-by-step.....	14	8.5 Dimensions .....	35
4.8 Accessories connector (dry contacts) ...	17		

## 1 SAFETY INSTRUCTIONS

# IMPORTANT SAFETY INSTRUCTIONS

## SAVE THESE INSTRUCTIONS

### 1.1 General

1. This manual contains important safety and operating instructions for the following models:

Model	Part number
CombiMaster 12V/2000W-100A 120V	35512000
CombiMaster 12V/3000W-160A 120V	35513000
CombiMaster 24V/2000W-60A 120V	35522000
CombiMaster 24V/3000W-70A 120V	35523000

These models are further mentioned as “CombiMaster Inverter/Charger“.

2. CAUTION – To reduce risk of injury, the CombiMaster Inverter/Charger may only be used for charging Lead-acid type (flooded, Gel, AGM) or Mastervolt Lithium Ion rechargeable batteries and the supply of users attached to these batteries, in permanent systems. Other types of batteries may burst causing personal injury and damage.
3. Do not expose the CombiMaster Inverter/Charger to rain, snow, spray, moisture, excessive pollution, aggressive environments, ammonia, salt or condensing circumstances.
4. Use of an attachment not recommended or sold by Mastervolt may result in a risk of fire, electric shock, or injury to persons.
5. Except for making the electrical connections, the CombiMaster Inverter/Charger may not be opened. There are no serviceable parts inside the casing. Do not disassemble the CombiMaster Inverter/Charger; take it to a qualified serviceman when service or repair is required. Incorrect reassembly may result in a risk of electric shock or fire.
6. To reduce risk of electric shock, disconnect the CombiMaster Inverter/Charger from both AC and DC electrical system before attempting any maintenance or cleaning. Turning off controls will not reduce this risk. Be sure that third parties cannot reverse the measures taken.
7. The CombiMaster Inverter/Charger is not ignition protected. Avoid serious injury or death from fire or explosion. Do not install in compartment containing gasoline-fueled engines or gasoline tanks, or in areas where ignition protected equipment is required.
8. The CombiMaster Inverter/Charger is not to be used by children or persons with reduced physical, sensory or mental capabilities, or lack of experience and knowledge, unless they have been given supervision or instruction.
9. In case of fire, you must use the fire extinguisher which is appropriate for electrical equipment.
10. CAUTION – Risk Of Electric Shock. Both AC and DC voltage sources are terminated inside this equipment. Each circuit must be individually disconnected before servicing.
11. CAUTION – Risk of electric shock from energy stored in capacitor. Do not remove cover until 5 minutes after disconnecting all sources of supply.

## 1.2 Warnings regarding the use of batteries

### 1. WARNING – RISK OF EXPLOSIVE GASES

- i. WORKING IN VICINITY OF A LEAD-ACID BATTERY IS DANGEROUS. BATTERIES GENERATE EXPLOSIVE GASES DURING NORMAL BATTERY OPERATION. FOR THIS REASON, IT IS OF UTMOST IMPORTANCE THAT EACH TIME BEFORE SERVICING THE COMBIMASTER INVERTER/CHARGER IN THE VICINITY OF THE BATTERY, YOU READ THIS MANUAL AND FOLLOW THE INSTRUCTIONS EXACTLY.
- ii. To reduce risk of battery explosion, follow these instructions and those published by battery manufacturer and manufacturer of any unit you intend to use in vicinity of battery. Review cautionary marking on these products and on engine.

### 2. PERSONAL PRECAUTIONS

- i. Someone should be within range of your voice or close enough to come to your aid when you work near a lead-acid battery.
- ii. Have plenty of fresh water and soap nearby in case battery acid contacts skin, clothing, or eyes.
- iii. Wear complete eye protection and clothing protection. Avoid touching eyes while working near battery.
- iv. If battery acid contacts skin or clothing, wash immediately with soap and water. If acid enters eye, immediately flood eye with running cold water for at least 10 min and get medical attention immediately.
- v. NEVER smoke or allow a spark or flame in vicinity of battery or engine.
- vi. Do not short circuit battery! Be extra cautious to reduce risk of dropping a metal tool onto battery. It might spark or short-circuit battery or other electrical part that may cause explosion.
- vii. Remove personal metal items such as rings, bracelets, necklaces, and watches when working with a lead-acid battery. A lead-acid battery can produce a short-circuit current high enough to weld a ring or the like to metal, causing a severe burn.
- viii. NEVER charge a frozen battery.
- ix. If necessary to remove battery from a vessel or vehicle, always remove grounded terminal from battery first. Make sure all accessories in the vessels or vehicle are off, so as not to cause an arc.
- x. Be sure that the area around battery is well ventilated.
- xi. Clean battery terminals. Be careful to keep corrosion from coming in contact with eyes.
- xii. Study all battery manufacturer's specific precautions such as removing or not removing cell caps while charging and recommended rates of charge.
- xiii. Add distilled water in each cell until battery acid reaches level specified by battery manufacturer. This helps purge excessive gas from cells. Do not overfill. For a battery without cell caps (e.g. AGM, Gel or Li-ion batteries), carefully follow manufacturer's recharging instructions.
- xiv. A battery is heavy! It may become a projectile if it is involved in an accident! Ensure adequate and secure mounting and always use suitable handling equipment for transportation.

### 1.3 Location

#### 1. COMBIMASTER INVERTER/ CHARGER LOCATION

- i. Locate the CombiMaster Inverter/Charger away from battery in a separate, well ventilated compartment.
- ii. Never place the CombiMaster Inverter/Charger directly above battery; gases from battery will corrode and damage the CombiMaster Inverter/Charger.
- iii. Never allow battery acid to drip on the CombiMaster Inverter/Charger when reading gravity or filling battery.
- iv. Do not operate the CombiMaster Inverter/Charger in a closed-in area or restrict ventilation in any way. To reduce risk of fire hazard, do not cover or obstruct the ventilation openings.

### 1.4 Connections

#### 1. DC CONNECTION PRECAUTIONS

- i. Connect and disconnect DC output connections only after setting any switches of the CombiMaster Inverter/Charger to off position and removing AC connections or opening AC disconnect switch.
- ii. Short circuiting or reversing polarity will lead to serious damage to batteries, the CombiMaster Inverter/Charger, wiring as well as accessories. Fuses cannot prevent damage caused by reversed polarity and the warranty will be void.

#### 2. EXTERNAL CONNECTIONS TO CHARGER SHALL COMPLY WITH THE UNITED STATES COAST GUARD ELECTRICAL REGULATIONS (33CFR183, SUB PART I).

3. GROUNDING INSTRUCTIONS – The CombiMaster Inverter/Charger should be connected to a grounded, metal, permanent wiring system; or an equipment-grounding conductor should be run with circuit conductors and connected to equipment-grounding terminal or lead on unit. Connections to the CombiMaster Inverter/Charger should comply with all local codes and ordinances.

### 1.5 Warning regarding life support applications

Mastervolt products are not designed to be used as component of medical equipment, unless negotiated in the form of a written agreement between customer and/or manufacturer and Mastervolt. Such agreement will require the equipment manufacturer either to contract additional reliability testing of the Mastervolt parts and/or to commit to undertake such testing as a part of the manufacturing process. In addition, the manufacturer must agree to indemnify and not hold Mastervolt responsible for any claims arising from the use of the Mastervolt parts in the life support equipment.

## 2 GENERAL INFORMATION

### 2.1 Liability

Mastervolt can accept no liability for:

- Consequential damage resulting from the use of the CombiMaster Inverter/Charger.
- Possible errors in the included manual and the consequences of these.
- Use that is inconsistent with the purpose of the product.

**Disclaimer:** Our products are subject to continual development and improvement. Therefore, additions or modifications to the products may cause changes to the technical data and functional specifications. No rights can be derived from this document. Please consult our most current Terms & Conditions of Sale.

### 2.2 Warranty

The Mastervolt product warranty covers the CombiMaster 120V Series for the first two years after the purchase date, on the condition that the product is installed and used according to the instructions in this manual. Installation or use that do not comply with these instructions may result in under performance, damage or failure of the product and may void this warranty. The warranty is limited to the cost of repair and/or replacement of the product. Costs of labor or shipping are not covered by this warranty.

### 2.3 Identification label

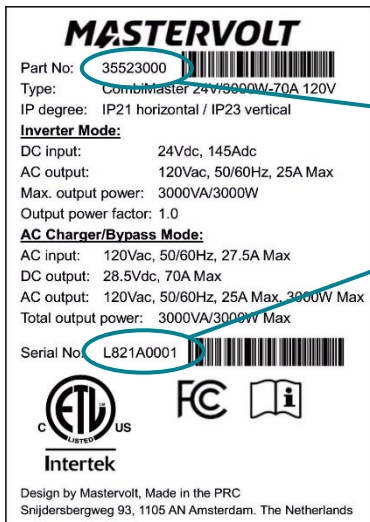

Part number

Serial number  
L821A0001,  
device version  
"A".

Important information required for service or maintenance can be derived from the identification label. The identification label is located at the right-hand side of the CombiMaster Inverter/Charger



#### CAUTION!

Never remove the identification label.  
This will void the warranty

Figure 1: Identification label

### 2.4 Correct disposal of this product



This product is designed and manufactured with high quality materials and components, which can be recycled and reused. Please be informed about the local separate collection system for electrical and electronic products. Please act according to your local rules and do not dispose of your old products with your normal household waste.

The correct disposal of your old product will help prevent potential negative consequences to the environment and human health.

### 3 PRODUCT DESCRIPTION

The CombiMaster Inverter/Charger is a battery charger, inverter and AC transfer system in one compact case.

#### 3.1 Overview of the connections

Front side with open connection compartment

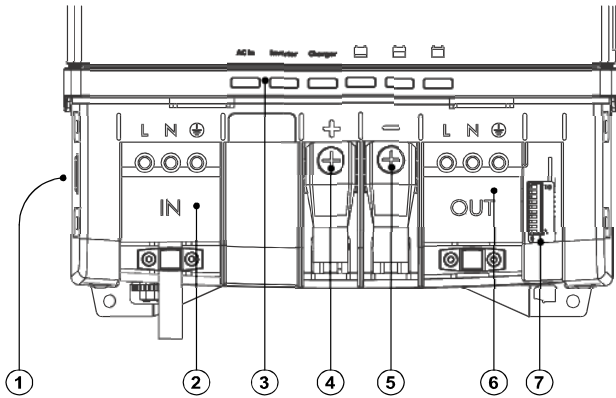

Bottom side

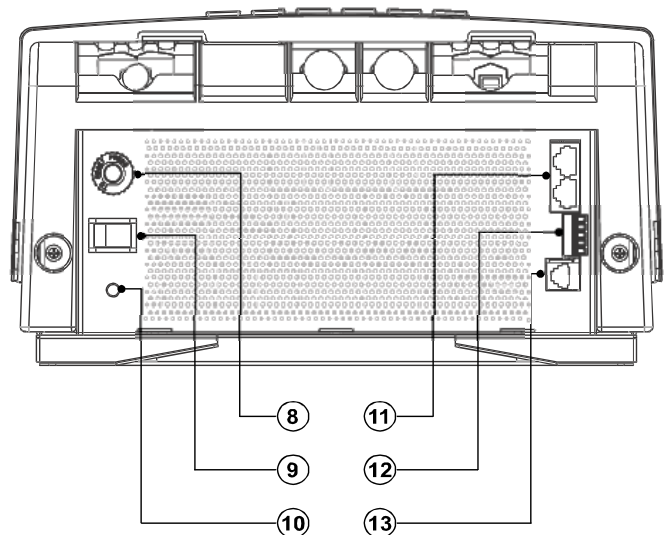
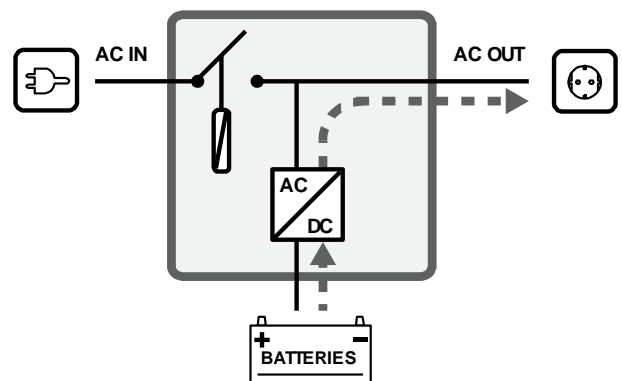

Figure 2. Connections

- |   |                                      |    |                               |
|---|--------------------------------------|----|-------------------------------|
| 1 | Grounding system jumper              | 8  | Resettable thermal fuse (30A) |
| 2 | AC input                             | 9  | Main switch                   |
| 3 | Status LEDs                          | 10 | 5/16" Ground stud             |
| 4 | Positive battery terminal [M8 screw] | 11 | CZone/MasterBus connection    |
| 5 | Negative battery terminal [M8 screw] | 12 | Accessories connector         |
| 6 | AC output power                      | 13 | Temperature sensor connection |
| 7 | DIP switches                         |    |                               |

#### 3.2 Operating modes

- Inverter mode;** When there is no external AC power available, the inverter provides AC power on the AC output. If energy saving mode is enabled, battery power consumption will be reduced when there is no (i.e. less than 20W for 10 seconds) load on AC OUT. Please note that small loads such as wifi routers, satellite receivers or digital clocks are most likely not to work in this mode.



- **Charger mode;** When external AC power is available on the AC input, the battery will be charged and the AC output is supplied by the external power.

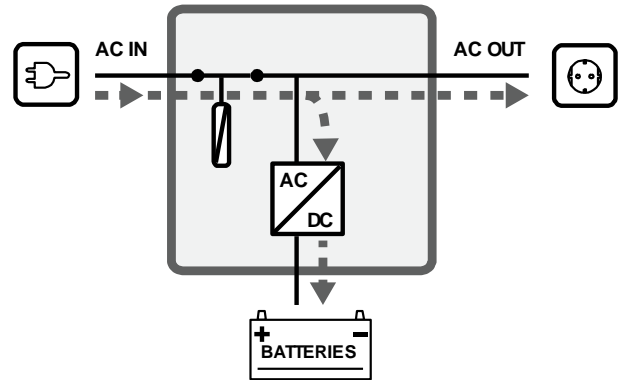

- **Power sharing mode;** The CombiMaster Inverter/Charger automatically reduces its battery charger output when the load connected to AC OUT increases while the available power at AC IN is limited. This avoids the external AC circuit breaker from tripping. The power sharing level, i.e. AC IN Limit setting (adjustable from a display), should be set to match the value of the external circuit breaker.

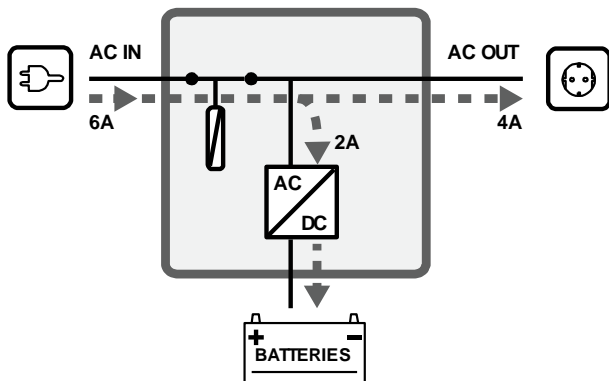

Load on AC OUT < AC IN Limit

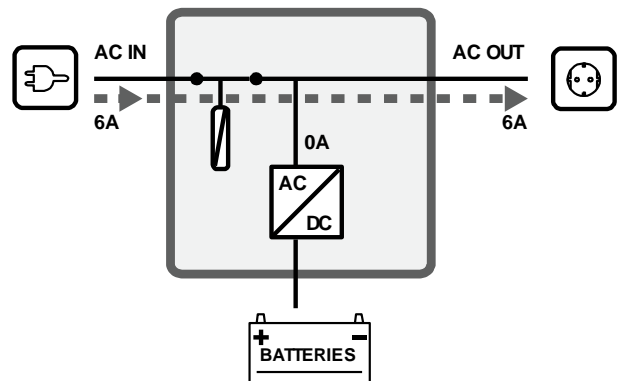

Load on AC OUT ≥ AC IN Limit

- **AC input support mode;** If the demand for AC power still increases, the external AC circuit breaker may still trip if nothing is done. This problem can be solved by the AC IN support mode. If the total demand for energy exceeds the maximum external power supply, energy can be added to AC OUT by means of the inverter. This means that the inverter adds energy from the batteries, in parallel with the external power source.



#### CAUTION!

The continuous load connected to AC OUT should never exceed 40A. Exceeding the max. allowable output current may damage the CombiMaster Inverter/Charger.

**Note:** Different countries have different regulations regarding AC sources operating in parallel with the AC grid. This may mean that in some situations AC IN support mode is not allowed! Familiarize yourself with local regulations on this issue. AC power from the inverter will never be fed back into the AC grid.

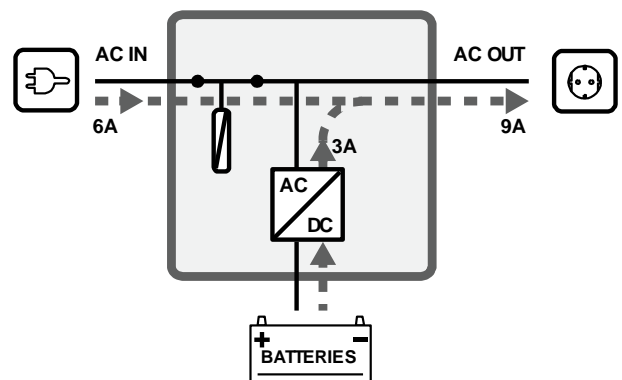

See chapter 5 on page 19 for the required settings.



### 3.3 Remote control

The CombiMaster Inverter/Charger can be monitored from a remote panel like the SmartRemote or a Touch 5 (in a CZone network). Some settings can only be adjusted from a laptop/notebook or PC connected to the CombiMaster Inverter/Charger via a USB Interface.

### 3.4 Protection

- **Overload or short circuit;** while in the inverter mode, the CombiMaster Inverter/Charger will shut down after 5 seconds of 200% overload or after 10 seconds 150%.
- **Transfer switch overload;** the transfer switch of the CombiMaster Inverter/Charger is protected against overload and short circuit. When the current through the transfer switch of the CombiMaster Inverter/Charger is too high, the thermal fuse (item 8 on page 7) will disconnect the AC input.
- **High temperature;** if the ambient temperature of the CombiMaster Inverter/Charger exceeds 104°F [40°C], it will reduce power. If it exceeds 140°F [60°C], it will shut down, trigger the status LEDs and optionally a remote alarm. As soon as the temperature drops below the factory default threshold, the inverter is powered up automatically or the charger resumes its charge current.
- **Battery low/high;** the CombiMaster Inverter/Charger can warn for low or high battery voltages by triggering status LEDs and CZone/MasterBus alarms.



#### CAUTION!

The CombiMaster Inverter/Charger is not protected against:

- serious over voltage on the AC input;
- serious continuous overload on the AC output.

Make sure AC input is within the range of 90-135V<sub>AC</sub> and the continuous load connected to AC OUT never exceeds 40A.

See section 6.2 on page 26 for an overview of the status LEDs. See chapter 5 on page 19 for the required settings.

## 4 INSTALLATION

### 4.1 Unpacking

The delivery includes:

- CombiMaster Inverter/Charger
- 1× Temperature sensor
- 1× MasterBus terminator
- 1× Drop cable CZone/MB (1m)
- Mounting bracket
- User and installation manual

After unpacking, check the contents for possible damage. Do not use the product if it is damaged. If in doubt, contact your supplier.

Check from the identification label (see section 2.3) whether the battery voltage is the same as the nominal output voltage of the CombiMaster Inverter/Charger (e.g. 24V battery set for a 24V battery charger). Also check that the AC output voltage and output power of the CombiMaster Inverter/Charger complies with your system and loads.

### 4.2 Location

- The CombiMaster Inverter/Charger is designed for indoor use only.
- Ambient temperature: 14°F to 140°F [-10°C to 60°C], power derating above 104°F [40°C].
- Humidity: 5-95% non-condensing
- This device requires a minimum of 4" [100mm] of clearance on every side to ensure safety and proper ventilation
- If the CombiMaster Inverter/Charger is installed in the immediate vicinity of living areas, take into account that the fan of the CombiMaster Inverter/Charger can produce noise when operating.
- If the CombiMaster Inverter/Charger is installed in a CZone or MasterBus network, take the network powering into consideration.
- The CombiMaster Inverter/Charger can be mounted horizontally (IP 21) as well as vertically (IP 23).
- FCC Class B notification: This equipment has been tested and found to comply with the limits for a Class B digital device, pursuant to part 15 of the FCC Rules. These limits are designed to provide reasonable protection against harmful interference in a residential installation. This equipment generates, uses and can radiate radio frequency energy and, if not installed and used in accordance with the instructions, may cause harmful interference to radio communications. However, there is no guarantee that interference will not occur in a particular installation. If this equipment does cause harmful interference to radio or television reception, which can be determined by turning the equipment off and on, the user is encouraged to try to correct the interference by one or more of the following measures:
  - Reorient or relocate the receiving antenna
  - Increase the separation between the equipment and receiver.
  - Connect the equipment into an outlet on a circuit different from that to which the receiver is connected.
  - Consult the dealer or an experienced radio/TV technician for help.

**Note:** The changes or modifications not expressly approved by the party responsible for compliance could void the user's authority to operate the equivalent.

4.3 Batteries

Model	Recommended battery capacity
12V/2000W-100A	200 – 1000 Ah
12V/3000W-160A	320 – 1600 Ah
24V/2000W-60A	120 – 600 Ah
24V/3000W-70A	140 – 700 Ah

Minimum based on Mastervolt Gel batteries. If connecting batteries of a different manufacturer, make sure the manufacturer's recommendations are met.

4.4 Connection example

**Note:** This schematic illustrates the general placement of the CombiMaster Inverter/Charger in a circuit. It is not meant to provide detailed wiring instructions for any particular electrical installation.

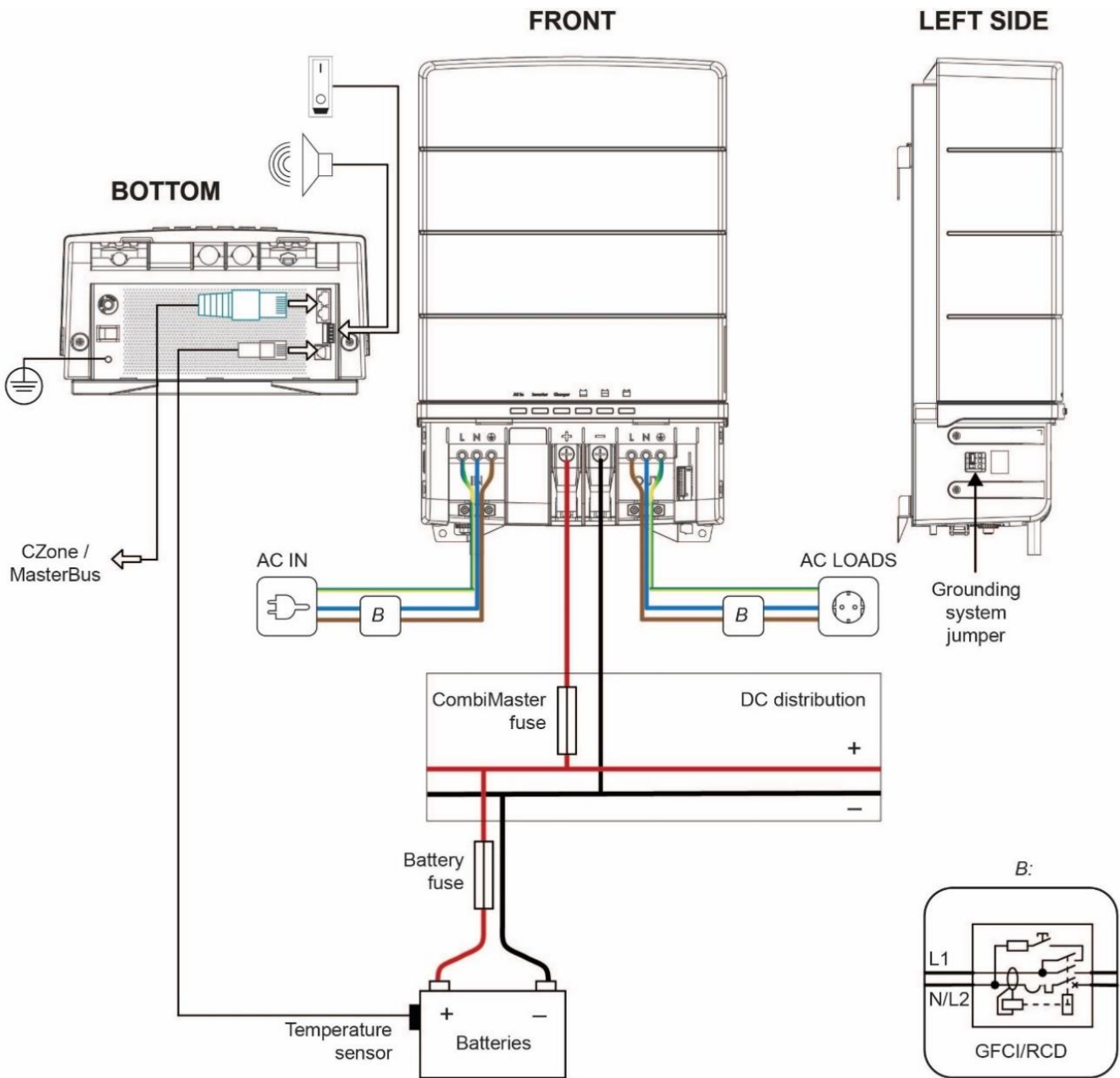

Figure 3: Installation drawing CombiMaster Inverter/Charger

## 4.5 Wiring



### WARNING!

The wire and fuse sizes stated in this manual are only guidelines. Always comply with all local rules and regulations.



### WARNING!

On first connecting to power, make sure the CombiMaster Inverter/Charger is in a well-ventilated area as it might spark.

### 4.5.1 DC wiring

Always keep your wire runs as short as practical to prevent low voltage shutdowns and to keep the DC breaker from nuisance tripping (or open fuses) because of increased current draw.

Model	DC cable cross section	
	<10ft [3m]	10-16ft [3-5m]
12V/2000W-100A	AWG 2/0 [70 mm <sup>2</sup> ]	AWG 3/0 [95 mm <sup>2</sup> ]
12V/3000W-160A	AWG 3/0 [95 mm <sup>2</sup> ]	AWG 4/0 [120mm <sup>2</sup> ]
24V/2000W-60A	AWG 2 [35 mm <sup>2</sup> ]	AWG 1/0 [50 mm <sup>2</sup> ]
24V/3000W-70A	AWG 1/0 [50 mm <sup>2</sup> ]	AWG 2/0 [70 mm <sup>2</sup> ]

Use 5/16" [M8] cable lugs on the ends of the wires. These lugs should be crimped with a proper crimping tool. Recommended wire colors (refer to local rules):

Wire color	Meaning	Connect to:
Red	Positive	+ (POS)
Black or yellow	Negative	– (NEG)

Do not put anything between the battery cable ring lug and the battery post or the inverter's DC terminal. When connecting the battery cable to the battery post or inverter DC terminal, the cable should be placed directly against the inverter terminal or battery post. Incorrectly installed hardware causes a high resistance connection which could lead to poor inverter/charger performance and may affect the cable and terminal connections.

Run the cables next to each other to limit the electromagnetic field around the cables. The negative cable should be connected directly to the negative post of the battery bank or the ground side of a current shunt. Do not use the chassis frame as the negative conductor. Tighten securely. The positive cable must be fused and connected to the positive post of the battery bank. Use a fuse that matches the applied wire size. The fuse with fuse-holder is available from your local Mastervolt distributor.

### 4.5.2 AC wiring



### WARNING!

The ground wire offers protection only if the case of the CombiMaster Inverter/Charger is connected to the safety ground. Connect the ground terminal (PE / GND) to the hull or the chassis the boat or vehicle that this CombiMaster Inverter/Charger is equipped on.



### WARNING!

For safety reasons Ground Fault Circuit Interrupters (GFCIs), also known as Residual Current Devices (RCDs), must be integrated in the AC input *and* AC output of the CombiMaster Inverter/Charger. Always comply with all local rules and regulations.

For a safe installation the correct wire cross section must be applied. Don't use a cross section that is smaller than indicated. Recommended cross section for the AC wiring:

AC Current	Minimum cross section
0-20 A	AWG 14 [2.5 mm <sup>2</sup> ]
20-32 A	AWG 12 [4 mm <sup>2</sup> ]

Recommended wire colors (refer to local rules):

Wire color		Meaning	Must be connected to
Europe	USA		
Brown	Black	Phase	L1
Blue	White	Neutral	N
Green/Yellow	Green	Earth	PE / GND

#### 4.5.3 AC Safety grounding



##### WARNING!

For safety reasons Ground Fault Circuit Interrupters (GFCIs), also known as Residual Current Devices (RCDs), of 30mA must be integrated in the AC input and AC output of the CombiMaster Inverter/Charger. Refer to locally applicable regulations regarding grounding of autonomous power systems.

##### Neutral to Ground Bonding

To ensure a correct operation of Ground Fault Circuit Interrupters (GFCIs), the grounding system jumper (located on the left side of the CombiMaster Inverter/Charger) must be placed between N and PE. Then the Neutral (N) output is automatically connected to the Safety Ground (PE / GND) if the AC input of the CombiMaster Inverter/Charger is disconnected from an external AC source.

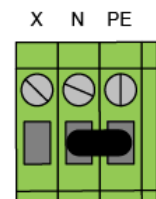

*Default setting*

#### 4.5.4 Network wiring (CZone/MasterBus)

The CombiMaster Inverter/Charger can be connected to a CZone or MasterBus network. For CZone, use an RJ45 Drop cable CZone/MB. For MasterBus, use a MasterBus cable and daisy chain the CombiMaster Inverter/Charger to the other devices. Both networks need a terminating device on both ends of the network. Do not make ring networks. For more details on networks, please contact your Mastervolt supplier.

#### 4.6 Things you need

Make sure you have all the parts you need to install a CombiMaster Inverter/Charger:

- CombiMaster Inverter/Charger (included).
- Battery temperature sensor with cable and plug (included).
- For CZone setup, an RJ45-M12 Drop cable CZone/MB (included) and a tee connector (not included).
- For MasterBus setup, an RJ45 MasterBus cable (not included).
- DC cables to connect the CombiMaster Inverter/Charger to the batteries and common negative. See section 4.5.1 for specifications.
- DC fuse holder with a DC fuse, to be integrated in the positive DC cable (as per ABYC recommendations).
- Screws/bolts (Ø ¼" / 6mm) with plugs to mount the CombiMaster Inverter/Charger to a surface. Use mounting materials which are suited to carry the weight of the CombiMaster Inverter/Charger.

- AC cable to connect the AC input to an AC power source. See section 4.5.2 for specifications.
- Batteries. See section 4.3 for specifications.
- Appropriate and reliable cable terminals, cable lugs, battery terminals and cord end terminals.

We recommend as a minimum tool kit:

- Socket wrench to fix the main DC cables ( $\frac{1}{2}$ " / 13mm)
- Socket wrench to fix the Safety ground connection ( $\frac{3}{8}$ " / 10mm).
- Flat blade screw driver to fix the screw terminals of the AC wiring.
- Tools to fix the screws / bolts ( $\varnothing \frac{1}{4}$ " / 6mm) with plugs to mount the CombiMaster Inverter/Charger to a surface.
- Philips screw driver to open the connection compartment.

#### 4.7 Installation step-by-step

**Step 1.** Turn off the electrical power.

**Step 2.** On a solid surface, mark the holes for the mounting bracket and secure the mounting bracket to the surface.

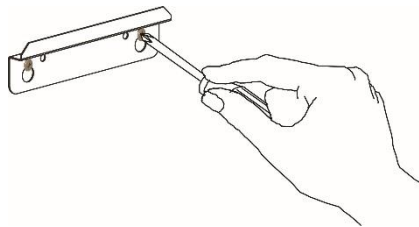

Wall mounted



Tabletop mounted

**Step 3.** Place the CombiMaster Inverter/Charger over the mounting bracket and then downwards until it snaps into place.



**Step 4.** Fix the CombiMaster Inverter/Charger to the surface by fastening two screws at the lower side of the case as well.



**Step 5.** Connect the 5/16" grounding lug to the central grounding point.

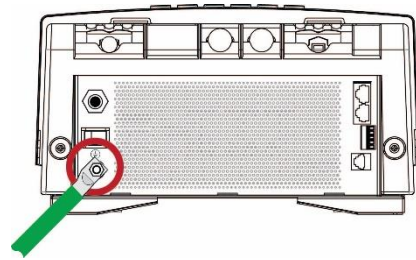

**Step 6.** Open the connection compartment by loosening the two screws at the bottom and then lifting the front cover plate.

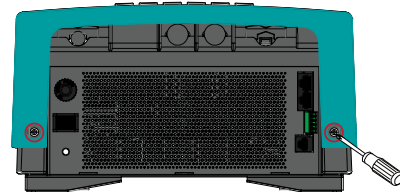

**Step 7.** Connect the AC wiring to the screw terminals. Fasten the cables with a strain relief.

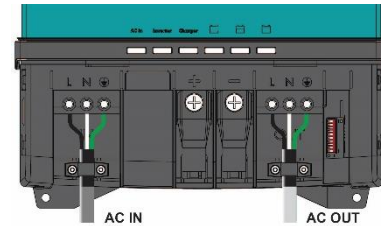

**Step 8.** Integrate a fuse holder in the positive battery wire but do not place the fuse yet!  
Fit crimp-on ring terminals, 5/16" [M8], to the DC cables.  
Connect the DC cabling of the battery bank; positive to +, negative to – .

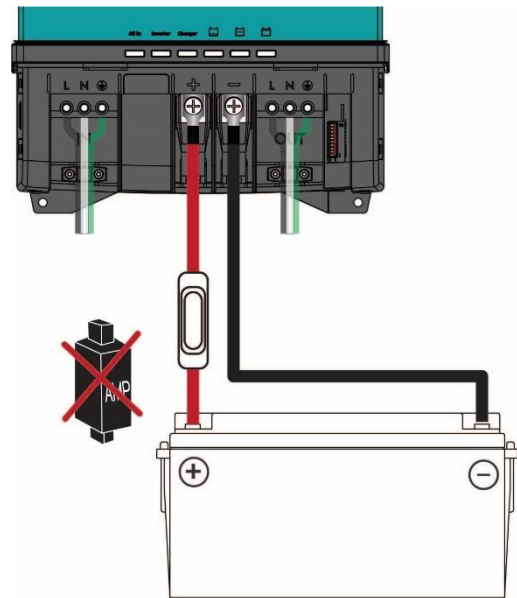

**Step 9.** Attach the battery temperature sensor to the casing of the battery bank. Then plug the temperature sensor cable into the "temp.sensor" jack.

**Note:** Lithium-ion batteries require no temperature sensor.

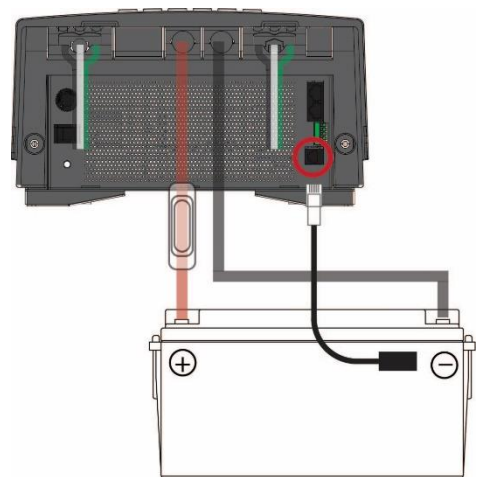

**Step 10.** On the left side of the CombiMaster Inverter/Charger check the jumper selecting the grounding system. See section 4.5.3 on page 13.

**Step 11.** Option: Connect the CombiMaster Inverter/Charger to the CZone or MasterBus network. See section 4.9 for more information on system integration.



#### Adding the CombiMaster Inverter/Charger to a CZone network

- 1 Disconnect the backbone at the closest backbone connection and add in a tee connector.
- 2 Reconnect the backbone connection(s) with the new tee connector in place.
- 3 Connect the RJ45 CZone/MB drop cable to the black coupler on the tee and then connect to the CombiMaster Inverter/Charger.



#### Adding the CombiMaster Inverter/Charger to a MasterBus network

- 1 Disconnect a MasterBus cable or Terminator from the closest MasterBus device and connect it to the CombiMaster Inverter/Charger.
- 2 Connect the new MasterBus cable to the other MasterBus device and then connect to the CombiMaster Inverter/Charger.



Ensure that the network is properly terminated.

**Step 12.** Option: use a small screw driver to change DIP switch settings. See section 5.1 on page 19.

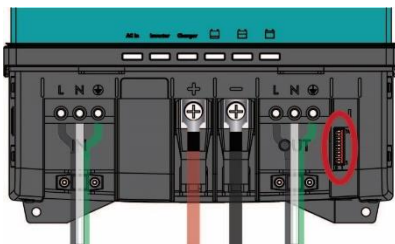

**Note:** if added to a CZone network, the DIP switches are used to set the CZone address during configuration.

**Step 13.** Option: connect external alarm or remote switch input. See section 4.8.

**Step 14.** Set the desired output voltage and other configuration settings using a remote control panel or the DIP switches, see chapter 5 on page 19.

**Step 15.** Check all wiring. If all wiring is OK: Place the inverter fuse.



#### WARNING!

When the fuse is placed, internal capacitors may cause a spark. This is normal

**Step 16.** Close the connection compartment and fix the screws at the bottom.

**Step 17.** Switch on the CombiMaster Inverter/Charger.



### 4.8 Accessories connector (dry contacts)

The screw terminal at the bottom side of the CombiMaster Inverter/Charger, offers the following contacts:

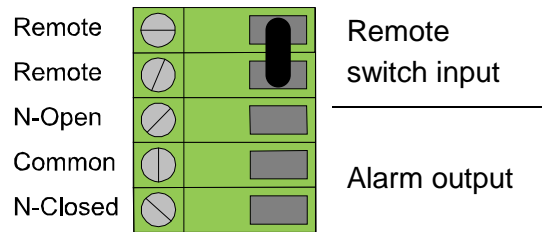

#### 4.8.1 Remote switch

By default, the upper two contacts (Remote) of the accessories connector are connected by a jumper to close the circuit. If desired, use these contacts to connect a remote switch that mimics the main On/Charge only switch:

- Use the Remote contacts to use the ignition lock. In this case, the CombiMaster Inverter/Charger's main switch must be in the off position (O). Closed = On, Open = Charge only.

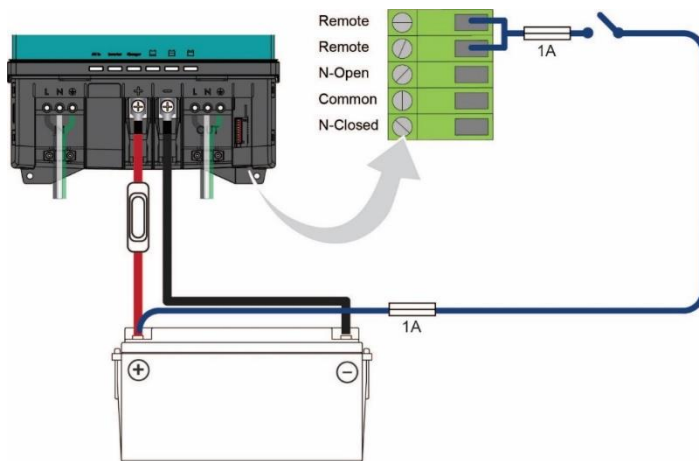

- Use both contacts to connect an external switch. In this case, the CombiMaster Inverter/Charger's main switch must be in the on position (I). Closed = On, Open = Charge only.

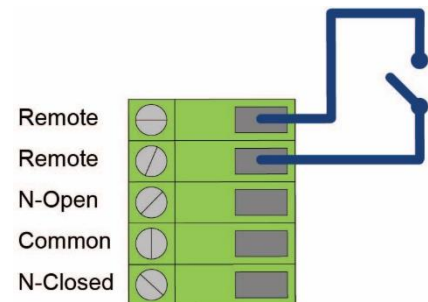

#### 4.8.2 Alarm output

The lower three contacts of the accessories connector can be used to control external equipment, like an alarm or light, to indicate the occurrence of a CombiMaster Inverter/Charger alarm. The alarm outputs support *Normally Closed* and *Normally Open* systems and is either alarm triggered, or power level triggered.

Trigger	Condition	Contact state
Alarm	A fault is detected	N-Open and Common connected (CombiMaster Inverter/Charger off)
	No fault is detected	N-Closed and Common connected
Power level	Inverter power < power level setting	N-Open and Common connected (CombiMaster Inverter/Charger off)
	Inverter power > power level setting	N-Closed and Common connected

See also section 5.2.4 for the dry contact alarm function in the configuration settings.

Max load: 250VAC, 30VDC, 3A.

## 4.9 System integration (CZone/MasterBus)

The CombiMaster Inverter/Charger can be connected to a CZone or MasterBus network.

- **CZone network**

Points to consider:

- Up to 40 devices can be connected together on a single backbone.
- Make sure the CZone network has two terminating resistors, one at each open end of the backbone.
- The electric power for the network comes from a battery or power supply. Make sure that it delivers enough power and is positioned as close to the middle of the backbone run as possible to reduce voltage drop.
- Each device on the CZone network has a unique CZone address; the Dipswitch. This number is usually assigned automatically during configuration and must match the DIP switch settings. This is done in the CZone Configuration Tool.

- **MasterBus network**

Use an RJ45 MasterBus cable (not included) and daisy chain the CombiMaster Inverter/Charger to the other MasterBus devices, forming a local data network.

Points to consider:

- Connections between the devices are made by standard MasterBus cables. Mastervolt can supply these cables.
- Up to 63 MasterBus devices can be connected together.
- MasterBus needs a terminating device on both ends of the network.
- The electric power for the network comes from the connected devices according to the rule: 1 powering / 3 non-powering. Spread the powering devices over the network
- Do not make ring networks.
- Do not make T-connections in the network.



**CAUTION!**

Never connect a non-MasterBus device to the MasterBus network directly! This will void warranty of all MasterBus devices connected.

For more details on networks, please contact your Mastervolt supplier.

## 5 SETTINGS

Adjustment of the settings of the CombiMaster Inverter/Charger can be made in two different ways:

- By means of DIP switches.
- From a laptop connected to the CombiMaster Inverter/Charger via a USB Interface. Some settings, like the AC IN Limit setting for example, can only be changed in this way.



### CAUTION!

Invalid settings of the CombiMaster Inverter/Charger can cause serious damage to your batteries and/or the connected load! Adjustment of settings must be carried out by authorized personnel only.

### 5.1 DIP switch settings

Use a small screwdriver to carefully set the required settings.

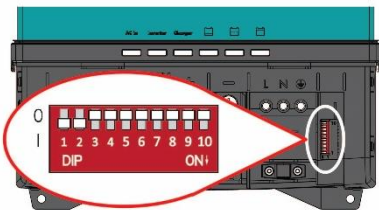

DIP switch 1 = CZone network (0↑) or MasterBus network (1↓).

DIP switch 2 = MasterBus powering off (0↑) or on (1↓)

DIP switches 3 to 10 are either used as CZone address or for MasterBus battery and 3<sup>rd</sup> output settings.

Figure 4. DIP switches (factory settings)

#### In a CZone network:

DIP switch 1 must always be set to the OFF position (0 ↑).

DIP switch 2 must always be set to the OFF position (0 ↑).

DIP switches 3 to 10 must match the unique address used in the CZone network; the dipswitch (see the CZone Configuration Tool Instructions manual).

#### In a MasterBus network:

DIP switch 1 must always be set to the ON position (1 ↓).

DIP switch 2 is MasterBus Powering ON (1 ↓) or OFF (0 ↑). By default, this is OFF.

DIP switches 3 to 5 are used for battery type selection:

DIP switch	3	4	5
MasterBus settings (Flooded) <sup>1</sup>	0	0	0
Flooded (fixed)	0	0	1
AGM (fixed)	0	1	0
Gel (fixed)	0	1	1
MLI (fixed)	1	0	0
Constant voltage (13,25V) <sup>2</sup>	1	1	1

<sup>1</sup> If all DIP switches are in the OFF position (0 ↑), the settings suit a Flooded battery but can be changed in MasterAdjust.

<sup>2</sup> Constant voltage has no temperature compensation.

The following table lists the settings for DIP switches 6 to 9.

DIP switch	6	7	8	9
Inverter frequency 60Hz	0			
Inverter frequency 50Hz	1			
AC input support mode off		0		
AC input support mode on		1		
AC voltage input window wide			0	
AC voltage input window narrow			1	
Energy saving mode off				0
Energy saving mode on				1

## 5.2 MasterBus configuration

MasterBus is a CAN based data network for communication between Mastervolt devices. When the CombiMaster Inverter/Charger is connected, open MasterAdjust on a Windows laptop or notebook connected to the MasterBus network via a MasterBus USB interface. This tool runs on a Windows laptop or notebook. When the CombiMaster Inverter/Charger is connected to MasterBus, open MasterAdjust. The CombiMaster Inverter/Charger will be recognized by the MasterBus network automatically.

### 5.2.1 Monitoring

A display, like the SmartRemote, Touch 5 (CZone) or EasyView 5 (MasterBus), can be used to monitor the CombiMaster Inverter/Charger. See applicable user manuals for details. The following table lists the parameters as shown in MasterAdjust.

Menu	Description	Default	Adjustable range
<b>General</b>			
Device state	The operation mode: Standby; Charging; Inverting; Supporting; Alarm		(read only)
AC IN Limit	Fuse setting of the AC input	30A	0-30A
Inverter button	Button to switch off/on the inverter	On	On, Off
Charger button	Button to switch off/on the charger	On	On, Off
<b>DC IN/OUT</b>			
Charger state	Charger state: Off, Bulk, Absorption, Float		(read only)
Voltage	Battery voltage		(read only)
Current	Battery current (minus is discharging)		(read only)
Temperature	Battery temperature (if not connected: ---)		(read only)
<b>AC IN</b>			
Input Voltage	AC input voltage		(read only)
Input Current	AC input current		(read only)
Input Frequency	AC input frequency		(read only)
<b>AC OUT</b>			
Output Voltage	AC output voltage		(read only)
Output Power	AC output power		(read only)
Output Frequency	AC output frequency		(read only)
<b>Installer</b>			
Dry contact*	Status alarm contact		(read only)

\* Parameters marked with a \* are not available in CZone.

### 5.2.2 Alarms

The following table lists the parameters as shown in MasterAdjust.

Menu	Description
Temperature high	Internal temperature of the CombiMaster Inverter/Charger is too high.
Fan error	An error has been detected in the fan.
DC high voltage	Battery voltage is too high.
DC low voltage	Battery voltage is too low.
Overload	The loads exceed the nominal inverter power
Device error	Internal CombiMaster Inverter/Charger error.
AC IN error	AC input voltage or frequency out of range

### 5.2.3 History

The following parameters are only shown in MasterAdjust.

Menu	Description
Inverter runtime	Inverter mode operation hours
Charger runtime	Charger mode operation hours

### 5.2.4 Configuration Settings

The configuration can be done in MasterAdjust, from a laptop or notebook connected to the CombiMaster Inverter/Charger via a Mastervolt USB Interface. See applicable user manuals for details. The following table lists the parameters as shown in MasterAdjust.

**Notes:** - DIP switch settings overrule MasterBus settings. If DIP switches are not in their default setting, the corresponding MasterBus setting is greyed out.  
 - To be able to make changes to the configuration via MasterBus, DIP switch 1 must be in the ON position.

Value	Meaning	Default	Adjustable Range
<b>Device</b>			
Language*	Menu language of this device	English	English
Name	Name of this device. This name will be recognized by all devices connected to the MasterBus network	CombiMaster	0-12 chars
Device type	The CombiMaster Inverter/Charger model		(read only)
Lock config.*	Option to lock the configuration (installer level)	Off	On, Off
Factory reset button*	Button to restore the configuration's default values	Off	On, Off
<b>Inverter</b>			
Energy save mode	Option to enable Energy save mode	Off	On, Off
Frequency	Inverter frequency	60Hz	50, 60Hz
DC Low on*	Voltage level at which the inverter switches on (DC Low off alarm)	11.5 / 23.0V	10.7-12.5 / 21.4-25.0V
DC Low off	Voltage level at which the inverter switches off	10.2 / 20.4V	10.2-12.0 / 20.4-24.0V
<b>Charger</b>			
Max charge cur.	Maximum charging current	60 / 100A	0-60 / 0-100A
Battery type	Select the battery type	Flooded	User defined, AGM, Gel, Flooded, Li-Ion, Constant voltage
Constant voltage	Select the Constant output voltage	13.25V/26.5V	12-15 / 24-30V
<b>Bulk</b>			
Voltage	Maximum Bulk voltage	14.25 / 28.50V	12-15 / 24-30V
Minimum time	Minimum time that the charger stays in bulk phase	2 min	0-600 min
Maximum time	Maximum time the bulk phase lasts before the charger transitions to absorption	480 min	0-600 min
Start bulk time	Voltage level at which to start the bulk timer	13.25 / 26.50 V	12-15 / 24-30V

Value	Meaning	Default	Adjustable Range
<b>Absorption</b>			
Voltage	Absorption voltage	14.25 / 28.50V	12-15 / 24-30V
Minimum time	Minimum time that the charger stays in absorption phase	15 min	0-600 min
Maximum time	Maximum time that the charger stays in absorption phase	240 min	0-600 min
Return Amps	Return amps (% of maximum charge current)	6%	0-100%
<b>Float</b>			
Voltage	Float voltage	13.25 / 26.50V	12-15 / 24-30V
Return to Bulk s	Delay time before the charger returns to Bulk after reaching the Return to Bulk voltage	30 s	0-600sec
Return to Bulk V	Bulk return voltage. If the battery voltage has dropped below this voltage, the charger will return to bulk phase	12.80 / 25.60V	12-15 / 24-30V
<b>AC IN</b>			
AC IN support	Option to enable AC input support mode	Off	On, Off
Voltage range	AC voltage input window	Wide	Wide, narrow
<b>AC IN limits*</b>			
AC IN Limit A*	Fuse pre-setting A	6A	0-30A
AC IN Limit B*	Fuse pre-setting B	10A	0-30A
AC IN Limit C*	Fuse pre-setting C	16A	0-30A
<b>Dry contact (installer level)</b>			
Function	Select dry contact alarm function		Alarm, Power level
Power Level	Inverter output power level	60%	0-100%
Delay on	Delay on	5s	0-300 seconds
Delay off	Delay off	5s	0-300 seconds
<b>DIP Switches</b>			
1234567890*	Position of the DIP switches	0	0,1

\* Parameters marked with a \* are not available in CZone.

### 5.2.5 Events – System automation

A CZone/MasterBus device can be programmed to initiate an action at another connected device. This is very helpful in automation of your system but is not required. In MasterBus this is done by means of event based commands. In the Events tab you can program the CombiMaster Inverter/Charger to act as an event source. Events which occur during the operation of the CombiMaster Inverter/Charger will then trigger actions from other products. The following parameters are shown in MasterAdjust.

Field	Meaning	Value
Event x source	Select an event that triggers an action, e.g. Battery pre low.	See <i>Event source</i> list
Event x target	Select the device that should take action, e.g. the generator.	System dependent
Event x command	Select the parameter that must be changed on the target device, e.g. Activate.	See command list of the selected device
Event x data	Data, e.g. On, is linked to the command.	Off, On, Copy, Copy Invert, Toggle

Table 1: MasterBus event parameters

The CombiMaster Inverter/Charger can be configured as an *event source*. An event source can be used to initiate an *event command* and an *event action* by another device that is connected to the MasterBus.

Event source	Description
Inverting	The CombiMaster Inverter/Charger is in Inverter mode
Charging	The CombiMaster Inverter/Charger is in Charger mode
Supporting	The CombiMaster Inverter/Charger is in Supporting mode
Overload	The loads exceed the nominal inverter power
DC low voltage	The main battery voltage has dropped below the Low bat value
Alarm	A CombiMaster Inverter/Charger alarm has been triggered
AC IN present	AC input is present
Bulk	Charge phase Bulk
Absorption	Charge phase Absorption
Float	Charge phase Float
AC IN Limit A	AC input is set to 6A
AC IN Limit B	AC input is set to 10A
AC IN Limit C	AC input is set to 16A

Table 2: CombiMaster 120V Series MasterBus Event sources

When the CombiMaster Inverter/Charger is configured as an *event target* by another device, this device can initiate an *event command* and an *event action* to be performed by the CombiMaster Inverter/Charger.

Event command	Description
Inverter	Change the CombiMaster Inverter/Charger inverter state
Charger	Change the CombiMaster Inverter/Charger charger state
AC limit A	Fuse setting of the AC input is set to 6A (adjustable)
AC limit B	Fuse setting of the AC input is set to 10A (adjustable)
AC limit C	Fuse setting of the AC input is set to 16A (adjustable)
Bulk	Changes to charge phase Bulk
Absorption	Changes to charge phase Absorption
Float	Changes to charge phase Float

Table 3: CombiMaster 120V Series MasterBus Event commands

### 5.3 CZone configuration

The CZone® network is an NMEA 2000-compliant CAN-based system. When the CombiMaster Inverter/Charger is connected, open the CZone Configuration Tool on a Windows laptop or notebook connected to the CZone network. Either do the configuration while connected to the network or use a prepared configuration file (.zcf).

#### Adding the CombiMaster 120V Series to a CZone system configuration

**Precondition:** This section assumes that a CZone system is already configured and the CZone Configuration Tool is open.

In the CZone Configuration Tool, from the Modules tab, press the **Add** button.

From the **Module Type** drop-down list select **Inverter/Charge**.

From the **Inverter/Charge Type** drop-down list select the required model and continue with the following steps.

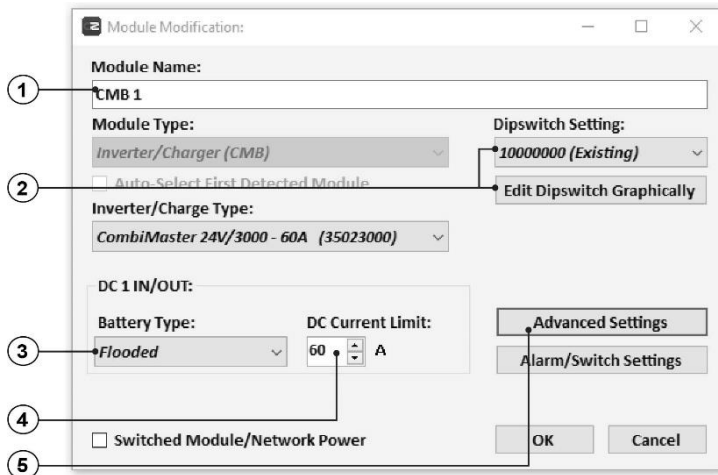

1. Enter an understandable **Module Name**.
2. Each device on a CZone network has a unique CZone address; the **Dipswitch**. This number must match the physical DIP switch settings. When connected to the system: either select one from the drop-down list or edit graphically.
3. Select the **Battery Type**.
4. Enter the **DC Current Limit**.
5. Options:
  - Press OK to save the settings and exit.
  - Press **Alarm/Switch Settings** and continue with step 14.
  - Press the **Advanced Settings** button and continue with the next step to configure advanced options.

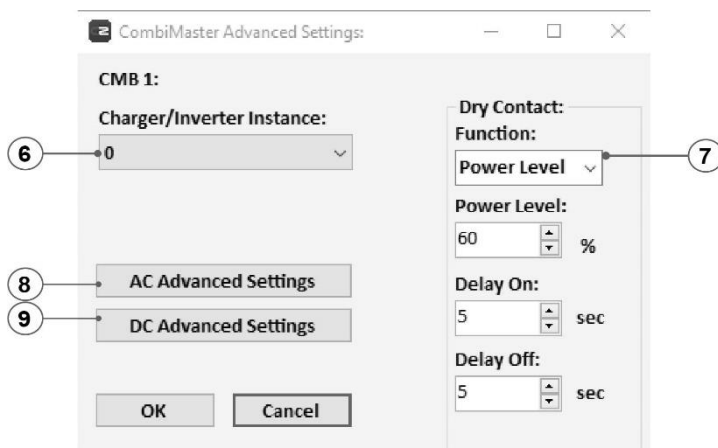

6. NMEA2000 **Instances** are used to differentiate between multiple monitoring sources.
7. From the **Function** drop-down list, select the required Dry Contact alarm function:
  - Power level (inverter output power level);
  - Alarm (has no additional settings).
8. Option: press **AC Advanced Settings** and go to step 10.
9. Option: press **DC Advanced Settings** and go to step 12.

Or press OK to save the settings and return to the Module Modification window.



**CombiMaster Advanced AC Settings:**

**CMB 1:**

**Inverter:**  
 Frequency: 50 Hz  
 Enable Energy Save Mode

**Transfer:**  
 AC IN Window: Wide  
 AC IN Support

**AC 1 IN:**  
 Name: CMB 1 - AC In  
 NMEA2000 AC Instance: 0  
 Transmit Alternate PGNs

**AC 1 OUT:**  
 Name: CMB 1 - AC Out  
 NMEA2000 AC Instance: 1  
 Transmit Alternate PGNs

OK Cancel

**CombiMaster AdvancedDC Settings:**

**CMB 1:**  
 DC 1 IN/OUT:  
 Name: CMB 1 - DC In/Out  
 NMEA2000 DC Instance: 0

**Inverter:**  
 DC Inverter Switch Off Criteria: Use Battery Type  
 Voltage: 20,40 V

**Bulk Settings:**  
 Voltage: 28,50 V  
 Minimum Timer: 2 Minutes  
 Maximum Timer: 480 Minutes  
 Start Timer At: 26,50 V

**Absorption Settings:**  
 Voltage: 28,50 V  
 Minimum Timer: 15 Minutes  
 Maximum Timer: 240 Minutes  
 Battery Full Current: 6 A

**Float Settings:**  
 Voltage: 26,50 V  
 Return to Bulk Timer: 30 Seconds  
 Return To Bulk Voltage: 25,60 V

OK Cancel

**CombiMaster Alarm Switch Settings:**

**CMB 1:**  
 DC 1 IN/OUT:  
 High Voltage: Standard  
 Low Voltage: Critical (Most Severe)

**General:**  
 Overload: Standard  
 Over Temperature: Standard  
 Inverter/Charger Error: Standard

OK Cancel

10. Check and adjust the AC settings. In Energy Save Mode the power consumption will be reduced when there is no load on AC OUT. Please note that small loads, such as the clock on a microwave oven, are most likely not to work in this mode. See section 3.2 for a description of AC IN Support. For a description of instances and PGNs, please refer to the CZone Configuration Tool Instruction manual.
11. Press **OK** to return to the Advanced Settings window.
12. Check and adjust the DC settings.
13. Press **OK** to return to the Advanced Settings window

14. Select the required Alarm Severities.
15. Press **OK**.

Optionally configure digital switching by adding Circuit Controls in the Circuits tab (e.g. a battery low switch can be used to start a generator). Write the configuration to the network to use the new configuration.



For more information, please refer to the CZone® Configuration Tool Instruction manual. Also see section 5.2. for a description of the same settings in MasterAdjust.

## 6 OPERATION

### 6.1 Switching On / Charge only

The main switch on the bottom of the CombiMaster Inverter/Charger has two positions:

- Inverter and charger on (I)
- Charge only, inverter off (O).

**Note:** When the main switch is in this position (O), it consumes 1mA DC power when not connected to AC. Switching off the inverter remotely, increases the DC power consumption. If it is necessary to put the CombiMaster Inverter/Charger out of operation, for winter storage for example, it is strongly recommended to switch the inverter off by the main switch

### 6.2 Status LEDs

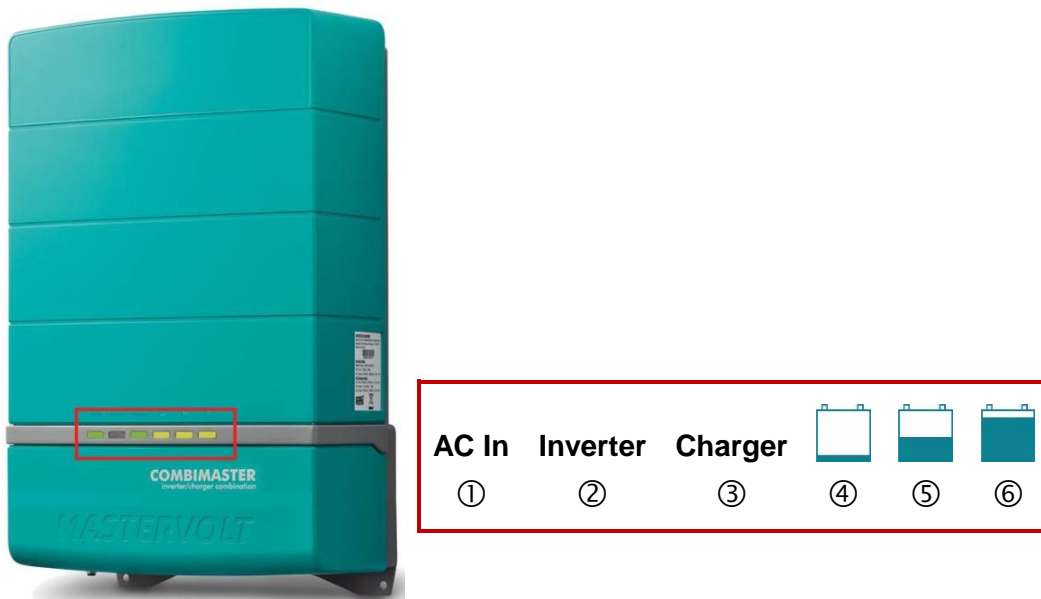

Figure 5: status LEDs

Off:

- ①: No AC input
- ②: Inverter off
- ③: Charger off

Green on:

- ①: AC input OK
- ②: Inverter on
- ③: Charger on
- ④: Charger in bulk phase
- ⑤: Charger in absorption phase
- ⑥: Charger in float phase
- ①+②: AC IN support mode

Green blinking:

- ②: Inverter power save mode active

Red on:

- ①: AC input out of range
- ④: battery voltage low warning/shutdown
- ⑥: battery voltage high causing shutdown

Red blinking:

- ②: AC output overload
- ②+③: Shutdown by any other error, including overtemperature of the CombiMaster Inverter/Charger
- ⑤: Battery temperature (sensor) error

Refer to the fault-finding table on page 30 for possible causes of problems.

### 6.3 3-step+ charge process

Battery charging is accomplished in three automatic stages: BULK, ABSORPTION and FLOAT. The first step is the BULK phase, in which the output current of the charger is 100%, and the greater part of the capacity of the battery is rapidly charged. The current charges the batteries and gradually the voltage rises to the BULK voltage. The duration of this phase depends on the ratio of battery to charger capacity, and the battery state of charge.

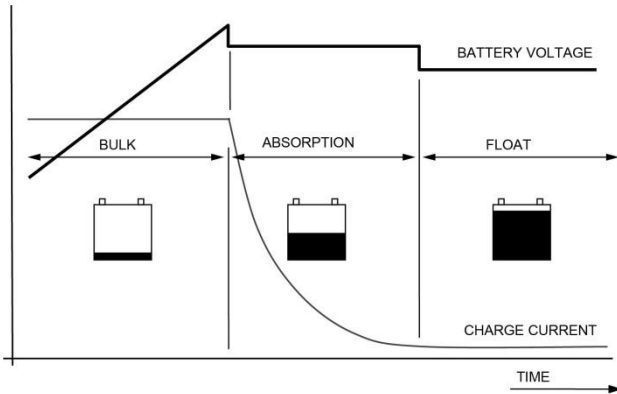

Figure 6: 3-step charge algorithm. See section 8.2 for detailed information.

The BULK phase is followed by the ABSORPTION phase. Absorption charging starts when the voltage on the batteries has reached the BULK voltage and ends when the battery is completely full. Battery voltage remains constant throughout this stage, and the charge current depends on the degree to which the battery was initially discharged, the battery type, the ambient temperature, etc. This stage lasts for 4 hours maximum. Once the battery is 100% full, the CombiMaster Inverter/Charger automatically switches over to the FLOAT phase.

Connected DC loads are powered directly by the charger. If the load exceeds the charger capacity, the required additional power comes from the battery, which will be progressively discharged until the charger automatically switches back to the bulk phase. Once consumption decreases, the charger goes back to normal operation of the 3-step+ charge system.

Connected to the CombiMaster Inverter/Charger, the batteries can be left unattended for weeks or months. One hour every 14 days the charger automatically switches to ABSORPTION to keep the battery running properly and prolong its life span. The 3-step+ charge system is also safe for all the connected equipment.



#### **WARNING!**

The MLI charging voltages on this charger fit the Mastervolt Li-ion (MLI) batteries but do not necessarily fit other Li-ion batteries! Always follow the instructions provided by the battery manufacturer!

## 6.4 Temperature compensated charging

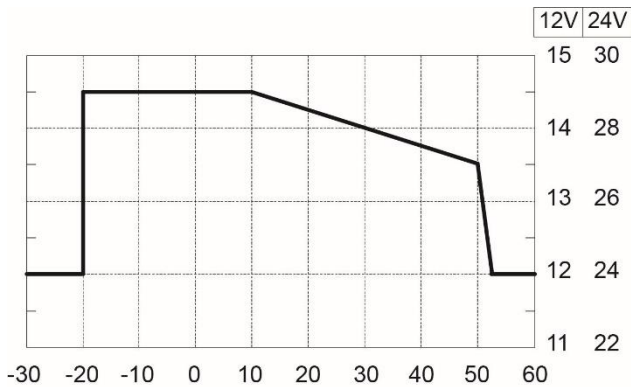

By installing the battery temperature sensor (for Lead Acid batteries only), the charge voltages are automatically adapted for deviating temperatures.

When the battery temperature is low, the charge voltage increases. On the other hand, when the battery temperature is high, the charge voltage is decreased. Overcharge and gassing are prevented this way. This will extend the life of your batteries.

Figure 7: Temperature compensated charging

## 6.5 Reset the thermal fuse after an overload

A thermal fuse protects the transfer switch of the CombiMaster Inverter/Charger against overload. If the status LEDs indicate an overload, proceed as follows:

- Step 1. Turn off AC power.
- Step 2. Move the main switch of the CombiMaster Inverter/Charger to the "Charge only" position (○).
- Step 3. Disconnect the CombiMaster Inverter/Charger from any power source.
- Step 4. Disconnect all loads from the CombiMaster Inverter/Charger.
- Step 5. Investigate the cause of failure of the thermal fuse like overload or short-circuits.
- Step 6. Wait for at least two minutes and then reset the fuse by pushing the button at the bottom side of the CombiMaster Inverter/Charger.

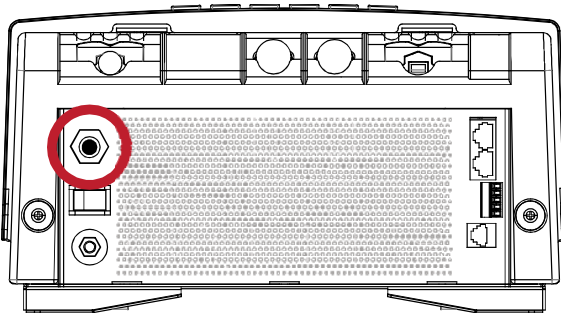

- Step 7. Connect the CombiMaster Inverter/Charger to the power sources again.
- Step 8. Move the main switch of the CombiMaster Inverter/Charger to the On position (■).

## 6.6 Maintenance

No specific maintenance to the CombiMaster Inverter/Charger is required. Examine your electrical installation on a regular basis, at least once a year. Defects such as loose connections, damaged wiring etc. must be corrected immediately.

If necessary, use a soft clean cloth to clean the CombiMaster Inverter/Charger. Do not use any liquids or corrosive substances, such as solvents, alcohol, petrol or abrasive components.

### 6.6.1 Decommissioning

If it is necessary to put the CombiMaster Inverter/Charger out of operation, follow the instructions in order of succession as described below:

- Step 1. Turn AC power off.
- Step 2. Remove the DC fuse(s) and disconnect the batteries.
- Step 3. Remove the AC fuse(s) of the AC input and/or disconnect the AC IN.
- Step 4. Open the connection compartment of the CombiMaster Inverter/Charger by loosening the two screws at the bottom and then lifting the front cover plate. The connectors for the battery, the AC and the remote panel are now visible.



**WARNING!**

Never remove the front panel while the CombiMaster Inverter/Charger is still connected to a power source!

- Step 5. Check with a suitable voltage meter whether the inputs and the outputs of the CombiMaster Inverter/Charger are voltage free.
  - Step 6. Disconnect all the wiring.
- Now the CombiMaster Inverter/Charger can be demounted in a safe way.

### 6.6.2 Storage and transportation

When not installed, store the CombiMaster Inverter/Charger in the original packing, in a dry and dust free environment.

## 7 TROUBLESHOOTING

If you cannot solve a problem using the fault-finding table, contact your supplier or Mastervolt. Make sure you have the part and serial number at hand.

Malfunction	Possible cause	What to do
No output voltage and/or current	No AC input	Check AC wiring, check remote control panel.
	AC input out of range (< 75VAC)	Check input voltage.
	AC input frequency out of range	Check input frequency.
	Thermal fuse has tripped	Check the load and reset the fuse (see section 6.5).
	Overheating error	Check whether the air flow of the CombiMaster Inverter/Charger is blocked or the ambient temperature is too high. Reduce the connected load and let the CombiMaster Inverter/Charger cool down.
	External breaker or GFCI (RCD) has tripped	Check the external breaker at the AC output (if applied).
Output voltage too low, charger supplies maximum current	Inverter is off	Check the main switch or the remote setting of the Inverter button.
	Load connected to the batteries is larger than charger can supply.	Reduce load taken from the batteries.
	Batteries not 100% charged	Measure battery voltage. After some time this will be higher.
Charge current too low	Wrong setting of the charge voltage	Check settings (see chapter 5).
	Batteries almost fully charged	Nothing, this is normal when the battery is almost fully charged.
	High ambient temperature	Nothing; if ambient temperature is more than the setting limit, the charge current is automatically reduced.
Batteries not fully charged	Low AC input voltage. At lower AC input voltages, the charge current is reduced.	Check AC input voltage.
	Charge current too low	See "Charge current too low" in this table.
	Current to load is too high	Reduce load taken from the batteries.
	Battery temperature too low	Use the battery temperature sensor.
	Defective or old battery	Check battery and replace if necessary.
	Wrong setting of the charge voltage	Check settings (see chapter 5).

Malfunction	Possible cause	What to do
Battery low causing CombiMaster Inverter/Charger shutdown	Discharged battery	Connect AC input to recharge battery <b>Note:</b> when charging an empty battery from a different power source, like an alternator, the CombiMaster Inverter/Charger must be reset manually by switching the main switch off and on again.
Batteries are discharged too fast	Battery capacity reduced due to wastage or sulphation, stagnation	Charge and recharge a few times, this might help. Check battery and replace if necessary.
Batteries are too warm, gassing	Defective battery (short circuit in cell)	Check battery and replace if necessary.
	Battery temperature too high	Use the battery temperature sensor.
	Charge voltage too high	Check settings (see chapter 5).
No remote control display function.	Display is switched off.	Switch on display, refer to display manual.
	Error in the CZone/MasterBus wiring.	Check the CZone/MasterBus cables.
Slow or no remote control communication.	Error in the CZone/MasterBus wiring.	Check the CZone/MasterBus cables.
	No terminator placed at the ends of the CZone/MasterBus network.	Check if a terminator is placed on both ends of the network.
	CZone/MasterBus network is configured as a ring network.	Ring networks are not allowed. Check the connections of the network.

## 8 TECHNICAL DATA

Specifications are subject to change without prior notice.

### 8.1 Inverter specifications

Model	12V/2000W-100A	12V/3000W-160A	24V/2000W-60A	24V/3000W-70A
<i>Part number/product code</i>	35512000	35513000	35522000	35523000
Nominal battery voltage	12V	12V	24V	24V
Inverter output voltage	120V (inverter only) or 90-140V (AC input support mode)			
Frequency	50Hz / 60Hz (configurable)			
Continuous power @ Tamb=77°F [25°C]	2000W	3000W	2000W	3000W
Continuous power @ Tamb=104°F [40°C]	2000W	2600W	2000W	2600W
Max. peak load (10sec)				150%
Max. peak load (5sec)				200%
Output waveform	True sine			
Max. efficiency	91%			
DC input voltage range	6-18V	6-18V	12-32V	12-32V
Switch off voltage low battery	10.2V	10.2V	20.4V	20.4V
Switch on voltage low battery	11.5V	11.5V	23.0V	23.0V
Switch off voltage high battery	16.0V	16.0V	32.0V	32.0V
Switch on voltage high battery	15.0V	15.0V	30.0V	30.0V
Max. ripple on DC @ full load				15%
Nominal DC current at full load	200A	300A	100A	150A
Recommended battery capacity (based on gel batteries)	200-1000Ah	320-1600Ah	120-600Ah	140-700Ah
<b>No load DC power consumption</b>				
Inverter off mode				<2mA
Energy saving mode				<10W
Normal operation mode				<30W



## 8.2 Charger specifications

Model	12V/2000W-100A	12V/3000W-160A	24V/2000W-60A	24V/3000W-70A
Input voltage range	70 – 140V (derating below 90V)			
Max AC input current	16A	25A	19A	22A
Max. charge current @Tamb=104°F [40°C]	100A at 14.25V	160A at 14.25V	60A at 28.5V	70A at 28.5V
Battery temperature sense	Input present, sensor included			
Battery temperature compensation	Yes			
Voltage sense	No			
Battery types	Flooded (default) / AGM / Gel / MLI / Constant voltage / User defined			
Charge characteristic	Mastervolt 3-step+, see the following table			
Flat battery charge	Yes, reduced (25%) charge current at low (<9V/<18V) battery voltage			

**Note:** the following charge specifications are based on Mastervolt batteries. Specifications for a given chemistry of a different manufacturer may vary. If connecting batteries of a different manufacturer, make sure the manufacturer's recommendations are met. Individual adjustments are possible if in the configuration the battery type "User defined" is selected. User defined batteries can only be configured through MasterAdjust or the CZone Configuration Tool.

Charging specifications				
Battery type	Flooded (default)	GEL	AGM	MLI
Bulk voltage*	14.40V [28.80V]	14.40V [28.80V]	14.40V [28.80V]	14.25/28.50 V
Max bulk time	480 min	480 min	480 min	480 min
Min bulk time	120 s	120 s	120 s	120 s
Start bulk time at*	13.25/26.50 V	13.25/26.50 V	13.25/26.50 V	13.25/26.50 V
Return to bulk voltage*	12.80/25.60 V	12.80/25.60 V	12.80/25.60 V	13.25/26.50 V
Bulk return time	30 s	30 s	30 s	240 s
Absorption voltage*	14.25/28.50 V	14.25/28.50 V	14.25/28.50 V	14.25/28.50 V
Max abs. time	240 min	240 min	240 min	240 min
Min abs. time	15 min	15 min	15 min	15 min
Return amps	6% I max	6% I max	6% I max	6% I max
Float voltage*	13.25/26.50 V	13.80/27.60 V	13.80/27.60 V	13.50/27.00 V

\* ± 1%

### 8.3 Transfer system specifications

Model	All models
AC input (switched)	30A
AC input fuse	Yes, resettable thermal fuse
AC output	Max connected continuous load: 40A*
Transfer speed	10ms for narrow input range, 20ms for wide range
Transfer voltage range	90-140V
Transfer frequency range	40-65Hz
Power sharing	Yes
AC IN support	Yes
Auto-synchronize with AC input	Yes

\* Exceeding the max. allowable output current may damage the CombiMaster Inverter/Charger.

### 8.4 Miscellaneous

Model	All models
Dimensions, h×w×d	17.6 × 11.2 × 6.1 inch [448 × 284 × 155 mm]
Weight	20.5 lb [9.3 kg]
Protection degree	IP 23 vertical wall mounted, IP 21 horizontal tabletop mounted
Safety class	IEC protection class I
Operating temperature	14°F to 140°F, derating above 104°F [-10°C to 60°C, derating above 40°C]
Storage temperature	-22°F to 158°F [-30 to 70°C]
Pollution degree	3
Relative humidity	Max 95% relative humidity, not condensing.
Standards, approvals & listings	UL1741, UL1236, FCC Class B
Front panel display	Yes, shows AC input state, Inverter state, charger state
Battery temperature sensor	Yes
Cooling	Vario fans
Parallel stacking	No
3-phase configuration	No
MasterBus powering	Yes
LEN (Load Equivalence Number)	0
<b>Protections</b>	
<i>AC input:</i>	
AC IN limit	Adjustable
Frequency monitoring	Relay disconnects when frequency is out of range
Voltage monitoring	Relay disconnects when voltage is out of range
<i>Output:</i>	
Short circuit protection	Yes (inverter only)
Overload protection	Yes (integrated resettable thermal fuse)
Over temperature protection	Yes
AC backfeed protection	Yes

## 8.5 Dimensions

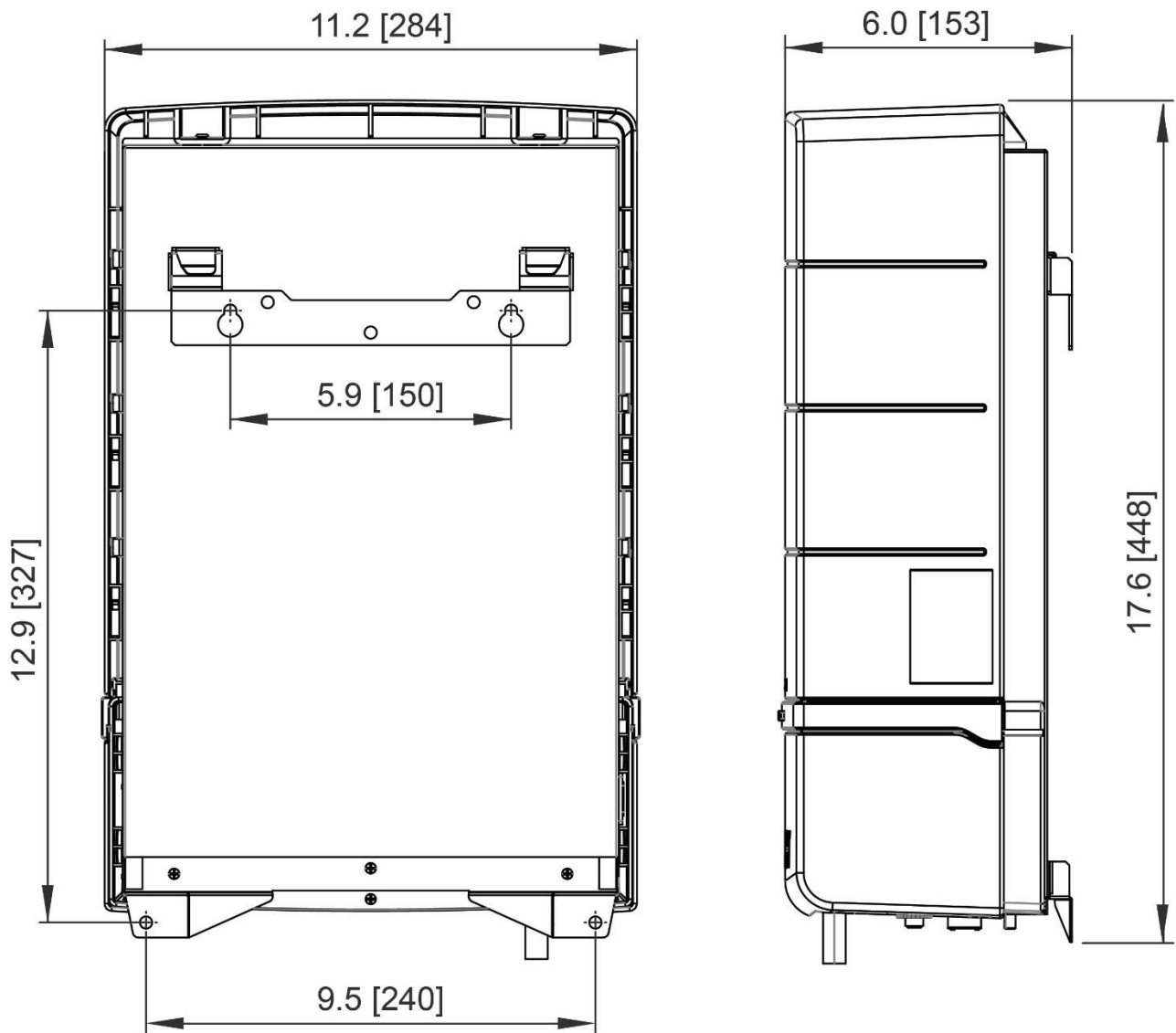

Figure 8. Dimensions in inches [mm]