

# MASTERVOLT

USERS MANUAL

## CHARGEMASTER

12/35-3, 12/50-3, 24/20-3, 24/30-3

FULL AUTOMATIC BATTERY CHARGER



**TABLE OF CONTENTS:**

10000008586/00 - February 2015

<b>1</b>	<b>GENERAL INFORMATION.....</b>	<b>3</b>
1.1	Use of this manual.....	3
1.2	Validity of this manual.....	3
1.3	Use of pictograms.....	3
1.4	Identification label.....	3
1.5	Liability.....	3
<b>2</b>	<b>OPERATION.....</b>	<b>4</b>
2.1	Features.....	4
2.2	Switching on / stand-by.....	4
2.3	LED display.....	5
2.4	Three Step charge algorithm.....	6
2.5	Masterbus (optional).....	7
2.6	Maintenance.....	7
2.7	Failures.....	7
<b>3</b>	<b>INSTALLATION.....</b>	<b>8</b>
3.1	Unpacking.....	8
3.2	Environment.....	8
3.3	Wiring.....	8
3.4	Batteries.....	9
3.5	Things you need.....	9
3.6	Overview connection compartment.....	10
3.7	Connection.....	10
3.8	Installation step by step.....	12
3.9	Commissioning after installation.....	14
3.10	Decommissioning.....	14
3.11	Storage and transportation.....	14
3.12	Re-installation.....	14
<b>4</b>	<b>SETTINGS.....</b>	<b>15</b>
4.1	DIP Switch settings.....	15
4.2	Equalize mode.....	15
4.3	MasterBus functions.....	16
<b>5</b>	<b>TROUBLE SHOOTING.....</b>	<b>20</b>
<b>6</b>	<b>TECHNICAL DATA.....</b>	<b>21</b>
6.1	Specifications 12V models.....	21
6.2	Specifications 24V models.....	22
6.3	Dimensions.....	23
<b>7</b>	<b>ORDERING INFORMATION.....</b>	<b>24</b>
7.1	MasterBus installation components.....	24
7.2	Miscellaneous.....	24

## 1 GENERAL INFORMATION

### 1.1 USE OF THIS MANUAL

This manual serves as a guideline for the safe and effective operation, maintenance and possible correction of minor malfunctions of the ChargeMaster

It is therefore obligatory that every person who works on or with the ChargeMaster must be completely familiar with the contents of this manual and the Important Safety Instructions, and that he/she carefully follows the instructions contained herein.

Installation of, and work on the ChargeMaster may be carried out only by qualified, authorised and trained personnel, consistent with the locally applicable standards and taking into consideration the Important Safety Instructions.

Copyright © 2014 Mastervolt. All rights reserved.  
 Reproduction, transfer, distribution or storage of part or all of the contents in this document in any form without the prior written permission of Mastervolt is prohibited

### 1.2 VALIDITY OF THIS MANUAL

All of the specifications, provisions and instructions contained in this manual apply solely to standard versions of the ChargeMaster delivered by Mastervolt. This manual is only valid for the following models with apparatus version "H" and higher (see section 1.4):

Part number	Model
44010350, 4401035x	ChargeMaster 12/35-3
44010500, 4401050x	ChargeMaster 12/50-3
44020200, 4402020x	ChargeMaster 24/20-3
44020300, 4402030x	ChargeMaster 24/30-3

x = OEM Customer specific number

These models are mentioned as "ChargeMaster" further in this manual.

### 1.3 USE OF PICTOGRAMS

Safety instructions and warnings are marked in this manual by the following pictograms:



#### WARNING

A WARNING refers to possible injury to the user or significant material damage to the charger if the user does not (carefully) follow the procedures.



#### CAUTION!

Special data, restrictions and rules with regard to preventing damage.



A procedure, circumstance, etc which deserves extra attention.

### 1.4 IDENTIFICATION LABEL

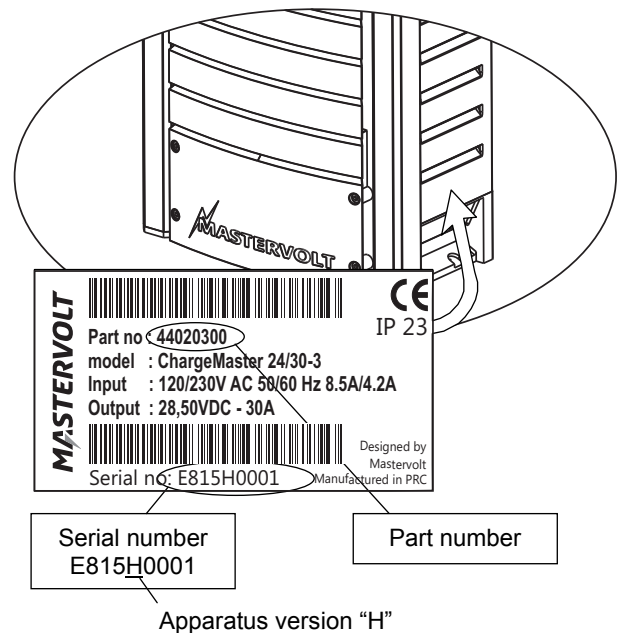

Figure 1: Identification label

The identification label is located at the right-hand side of the ChargeMaster (see Figure 1). Important technical information required for service, maintenance & secondary delivery of parts can be derived from the identification label.



#### CAUTION!

Never remove the identification label.

### 1.5 LIABILITY

Mastervolt can accept no liability for:

- consequential damage due to use of the ChargeMaster;
- possible errors in the manuals and the results thereof.

## 2 OPERATION

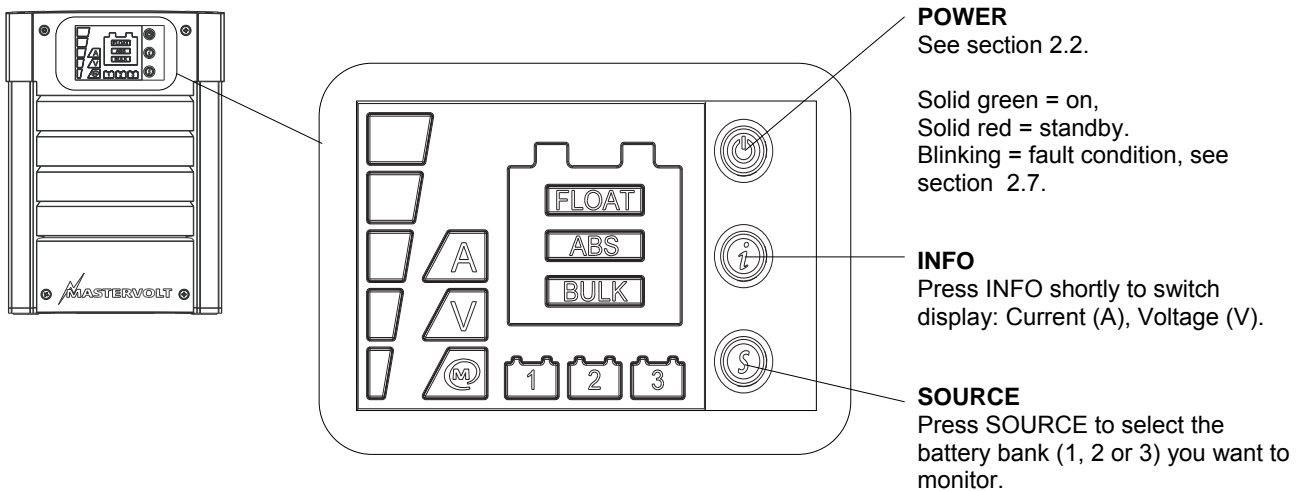

Figure 2: operation of the ChargeMaster

### 2.1 FEATURES

The Mastervolt ChargeMaster is a fully automatic battery charger. This means that under normal circumstances it may stay switched on with the AC power and batteries connected. The ChargeMaster is suitable for charging the following battery types: Flooded lead acid, AGM, Spiral, Gel, Deep cycle batteries and Mastervolt Li-Ion batteries (MLi). It has an auto-ranging input facility which makes it feasible to operate on almost any AC power source in the world. It operates on both 230V and 120V without compromising the output current. The three-step Plus charging method guarantees that the batteries are always charged to 100%.

With an external AC source connected, the ChargeMaster charger also serves the function of an AC to DC converter to supply DC loads which are connected to the batteries.



#### WARNING

The MLi charging voltages on this charger fit the Mastervolt Li-ion (MLi) batteries and do not necessarily fit other Li-ion batteries!. Always follow the instructions provided by the battery manufacturer!

### 2.2 SWITCHING ON / STAND-BY

The ChargeMaster is activated by holding the POWER switch pressed for approx. 5 seconds. The POWER switch will illuminate green. The state of charge (which is stored in the memory of the ChargeMaster) will be displayed. If necessary and if AC power is available, the ChargeMaster will start to charge the batteries.



Once switched on, the ChargeMaster automatically resumes operation after it was disconnected from an AC-source temporarily.

By pressing the POWER button again for approx. 5 seconds, the ChargeMaster will switch back to stand-by: the ChargeMaster stops and the POWER switch illuminates red.



#### WARNING

Switching the ChargeMaster to “stand-by” does not cut off the connection to the batteries or the AC-source. This means that voltages are still available inside the apparatus.

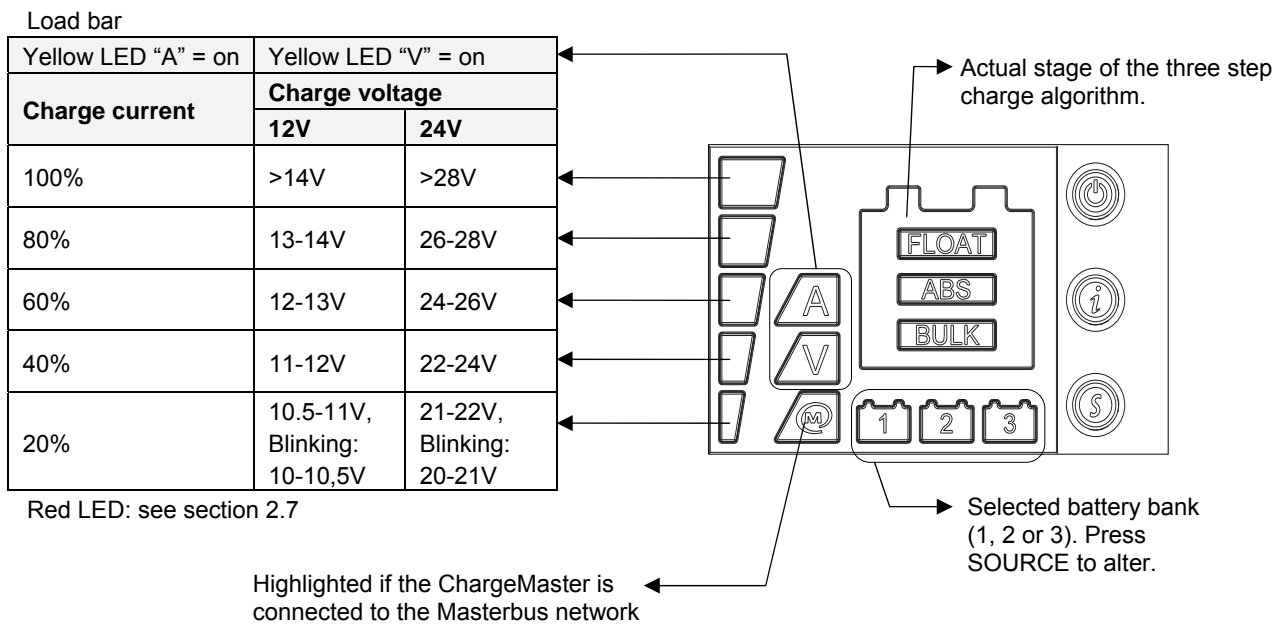

Figure 3: LED display

If the ChargeMaster was switched to stand-by or AC power became unavailable, the POWER switch starts blinking red. After approximately 2 minutes the blinking will stop and the display will switch off, thus preventing the ChargeMaster slowly draining the battery.



Only if DIP-switch #3 was adjusted to ON and the charger was switched on, the indication light stays blinking orange, indicating that the AC-power supply fails in operation. Note that this blinking LED may slowly drain your batteries. See section 4.1.3.



The ChargeMaster can also be operated and monitored remotely by means of a MasterBus remote control panel. See section 4.3 for details.

## 2.3 LED DISPLAY

The ChargeMaster is equipped with a multicolour LED display. See Figure 3. Different LED colours and combinations have different meanings. Combination of the current display (A) with the load bar shows the percentage of maximum current, of the three Battery banks together. Combination of (V) with the load bar shows the actual charging voltage.

If one of LEDs illuminates red, a fault condition is detected; see section 2.7

## 2.4 THREE STEP CHARGE ALGORITHM

See Figure 4. Battery charging is accomplished in three automatic stages: BULK, ABSORPTION and FLOAT.

The first step of the three step charge system is the BULK phase, in which the output current of the charger is 100%, and the greater part of the capacity of the battery is rapidly charged. The current charges the batteries and gradually the voltage rises to the BULK voltage 14.4V (MLi: 14.25V) resp. 28.8V (MLi: 28.5V) at 25°C / 77°F.

The duration of this phase depends on the ratio of battery to charger capacity, and the battery state of charge.

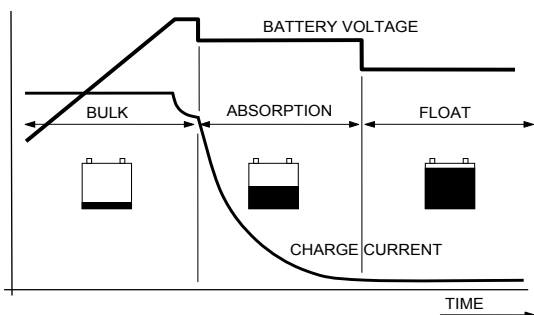

Figure 4: Three step charge system

The bulk phase is followed by the ABSORPTION phase. Absorption charging starts when the voltage on the batteries has reached the BULK voltage, and ends when the battery is completely full. Battery voltage remains constant at 14.25V / 28.5V at 25°C / 77°F throughout this stage, and the charge current depends on the degree to which the battery was initially discharged, the battery type, the ambient temperature, and so on. With a flooded battery this stage lasts approx. 4h, with gel and AGM around 3h. Once the battery is 100% full, the ChargeMaster automatically switches over to the float phase. At FLOAT (for Gel/AGM, flooded batteries) the ChargeMaster switches to a stabilised 13.25V (MLi: 13.5V) or 26.5V (MLi: 27.0V) at 25°C / 77°F.

Connected DC-loads are powered directly by the charger. If the load is higher than charger capacity, the required additional power comes from the battery, which will be progressively discharged until the charger automatically switches back to the bulk phase. Once consumption decreases, the charger goes back to normal operation of the three-step charge system.

As the ChargeMaster is equipped with a three-step Plus charge system, the batteries can also remain connected to the ChargeMaster during winter. One hour every 12 days the charger automatically switches to absorption to keep the battery running properly and prolong its life span. The three-step Plus charge system is also safe for all the connected equipment.



See also APPENDIX for detailed characteristics of the three step Plus charge system.

### 2.4.1 Temperature compensated charging

By installing the battery temperature sensor the charge voltages are automatically adapted for deviating temperatures.

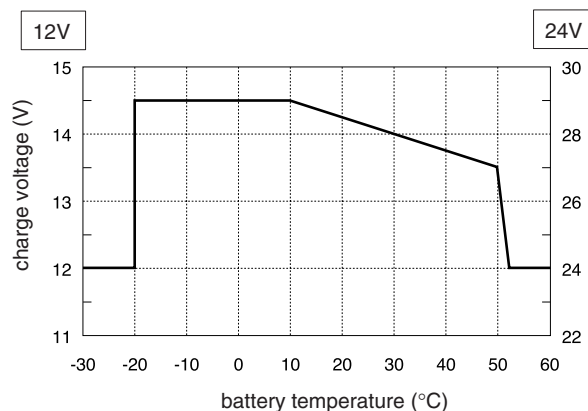

Figure 5: Temperature compensated charging

See Figure 5. When the battery temperature is low, the charge voltage increases. On the other hand, when the battery temperature is high, the charge voltage is decreased. Over charge and gassing are prevented this way. This will extend the life of your batteries.

### 2.4.2 Connection of a second and third battery

The ChargeMaster is equipped with three equal outputs. The total output current is divided over these three outputs. See chapter 3 for connection.

## 2.5 MASTERBUS (OPTIONAL)

The ChargeMaster is compatible with the MasterBus network: a fully decentralized data network for communication between the different Mastervolt system devices such as the inverter, battery charger, generator, batteries and many more. See APPENDIX for details.





## 2.6 MAINTENANCE

No specific maintenance to the ChargeMaster is required. Examine your electrical installation on a regular base, at least once a year. Defects such as loose connections, burnt wiring etc. must be corrected immediately.

If necessary, use a soft clean cloth to clean enclosure of the ChargeMaster. Do not use any liquids or corrosive substances, such as solvents, alcohol, petrol or abrasive components.

## 2.7 FAILURES

The ChargeMaster is protected against overload, short circuit, over heating and under and over voltage. If a fault condition occurs, a load bar segment on the display illuminates red. The LED position indicates the failure cause.

Load bar	Red LED
	<b>Fault condition</b>
	Wrong AC voltage**
	Charger failure**
	Battery voltage too high**
	Internal temperature too high**
	Battery low, short circuit*. Blinking: AC not available

\*At *Battery low* the battery bank number concerned is blinking. Selecting another bank is still possible then, the display will return after 5 seconds.

\*\*The POWER button is blinking.



### CAUTION!

The ChargeMaster is not protected against:

- reversed polarity on the DC-output,
- over voltage on the AC-input.

### 3 INSTALLATION

During installation and commissioning of the ChargeMaster, the important safety instructions are applicable at all times.

#### 3.1 UNPACKING

In addition to the ChargeMaster the delivery includes:

- Mounting bracket to mount the ChargeMaster to a wall;
- Battery temperature sensor;
- MasterBus terminating device (see APPENDIX);
- This User's manual
- Important Safety Instructions

After unpacking, check the contents for possible damage. Do not use the product if it is damaged. If in doubt, contact your supplier.

Check from the identification label (see section 1.4) whether the battery voltage is the same as the nominal output voltage of the ChargeMaster (e.g. 24V battery set for a 24V battery charger).

#### 3.2 ENVIRONMENT

Obey the following stipulations during installation:

- The ChargeMaster is designed for indoor use only.
- Ambient operating temperature: -25°C ... 60°C / -13°F ... 140°F (power de-rating above 25°C / 77 °F to decrease the internal temperature).
- Humidity: 0-95% non condensing.
- Mount the ChargeMaster preferably to a vertical wall, with the connecting cables downwards.
- Do not expose the ChargeMaster to excessive dust, aggressive environments, ammonia or salt.
- Make sure that the hot air that is developed during operation can be discharged. The ChargeMaster must be mounted in such a way that obstruction of the airflow through the ventilation openings will be prevented.
- No objects must be located within a distance of 10 cm / 4 inch around the ChargeMaster.
- Do not locate the ChargeMaster in the same compartment as the batteries.
- Do not install the ChargeMaster straight above the batteries because of possible corrosive sulphur fumes.
- If the ChargeMaster is installed in the immediate vicinity of living areas, take into account that the fan of the ChargeMaster can produce noise when operating.

- Although the ChargeMaster fully complies with all applicable EMC limits, it may still cause harmful interference to radio communication equipment. If such interference appears, it is recommended to increase the separation between the ChargeMaster and the equipment, to relocate the receiving antenna or to connect the equipment to a circuit different from that to which the ChargeMaster is connected.

#### 3.3 WIRING



##### WARNING!

The wire and fuse sizes stated in this manual are given as example only. Prescribed wire and fuse sizes may be different due to local applicable regulations and standards.

##### 3.3.1 DC wiring

Keep in mind that high current will pass through the DC wiring. Keep the cable length as short as possible, this will keep the system efficiency as high as possible. The recommended minimum cross section of the battery cables for output 1, 2 and 3 is:

Model	DC Cable cross section:	
	<2m / 6ft	2-5m / 6ft
12/35-3	16mm <sup>2</sup> / 4AWG	25mm <sup>2</sup> / 2AWG
12/50-3	25mm <sup>2</sup> / 2AWG	35mm <sup>2</sup> / 1AWG
24/20-3	10mm <sup>2</sup> / 6AWG	16mm <sup>2</sup> / 4AWG
24/30-3	16mm <sup>2</sup> / 4AWG	25mm <sup>2</sup> / 2AWG

Use ring terminals on the ends of the wires. The terminals must be crimped with a proper crimping tool. Use the following wire colours for DC wiring colour or at least different colours to make a clear distinction between the positive and negative wire from the battery:

Wire colour	Meaning	Connect to:
Red	Positive	+ (POS)
Black	Negative	- (NEG)



Lay the positive and negative cables next to each other to limit the electromagnetic field around the cables. The negative cable should be connected directly to the negative post of the battery bank or the ground side of a current shunt. Do not use the chassis frame as the negative conductor. Tighten securely. The positive battery cable must be fused and connected to the positive post of the battery bank.

The recommended DC fuses for outputs 1, 2 and 3 are:

Model ChargeMaster	DC fuse
12/35-3	40A
12/50-3	63A
24/20-3	32A
24/30-3	40A

The fuse with the fuse-holder is available from your local Mastervolt distributor or Customer Service Representative.

### 3.3.2 AC wiring

The AC cable and is pre-assembled to the ChargeMaster. The following wiring colours apply:

Wire color	Meaning	Connect to:
Brown	Hot/Line/ Phase	L1
Blue	Neutral	N
Green/Yellow	PE / Ground	PE / GND

### 3.3.3 AC safety grounding



#### WARNING!

The ground wire offers protection only if the enclosure of the ChargeMaster is connected to the safety ground. Connect the ground terminal (PE / GND) to the hull or the chassis.



#### CAUTION!

For safe installation it is necessary to insert a Residual Current Device (earth leakage switch) in the AC input circuit of the ChargeMaster.

## 3.4 BATTERIES

Always follow the instructions published by battery manufacturer. The minimum required battery capacity for Mastervolt gel batteries (MVG series) is as follows:

Model ChargeMaster	Minimum required battery capacity (MVG series)
12/35-3	85Ah
12/50-3	120Ah
24/20-3	55Ah
24/30-3	85Ah



See section 4.1.4 for minimum required battery capacity to meet the requirements of the CEC regulations (USA only).

## 3.5 THINGS YOU NEED

Make sure you have all the parts you need to install the ChargeMaster:

- ChargeMaster (included);
- Battery temperature sensor with cable and plug (included);
- DC cables to connect the ChargeMaster to the DC-distribution; see section 3.3.1 for specifications;
- DC-fuse holder with a DC-fuse, to be integrated in the positive DC-cable; see section 3.3.1 for specifications;
- Screws / bolts (Ø 4.5mm) (with plugs) to mount the enclosure to a surface. Use mounting materials which are suitable to carry the weight of the ChargeMaster;
- Batteries; see section 3.4;
- Appropriate and reliable cable terminals, cable lugs, battery terminals and cord end terminals.

We recommend as a minimum tool kit:

- Socket wrench 10mm to fix the DC-cables;
- Tools to fix the screws / bolts (Ø 4.5mm) with plugs to mount the enclosure to a surface;
- Philips screw driver nr. 2 to open the connection compartment and to fix the Safety ground connection;
- A small screw driver for adjustment of the DIP-switches.

**3.6 OVERVIEW CONNECTION COMPARTMENT**

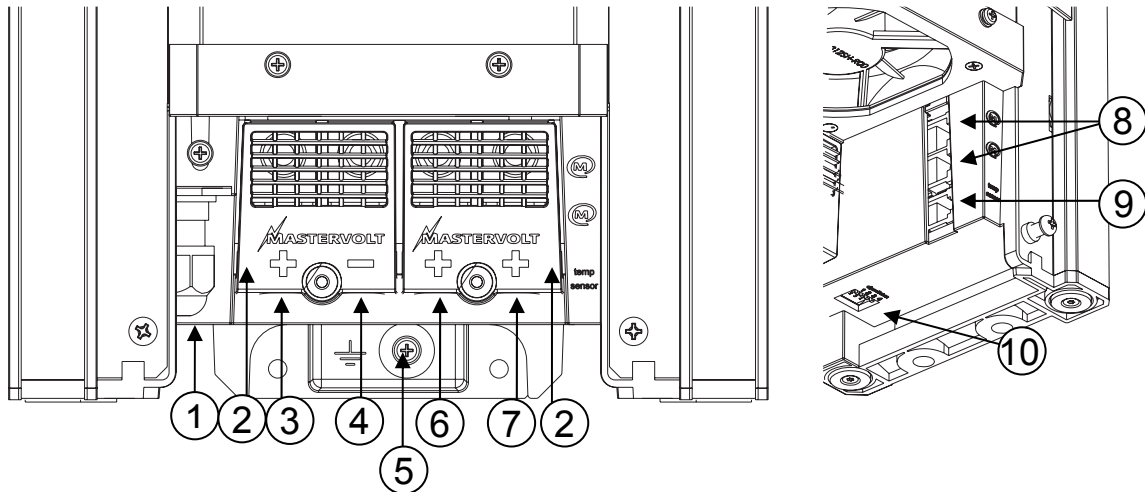

- 1. Cable gland for AC-wiring
- 2. Isolation caps for DC connections
- 3. Positive terminal charge output 1
- 4. Common negative output terminal
- 5. Safety ground connection
- 6. Positive terminal charge output 2
- 7. Positive terminal charge output 3
- 8. MasterBus connectors
- 9. Temperature sensor jack
- 10. DIP switches

Figure 6: Overview connection compartment

**3.7 CONNECTION**

**3.7.1 General**



**WARNING**

Let installation work be done by a licensed electrician.  
All electrical systems (AC and DC) must be disconnected from any power source during the entire installation!



**CAUTION!**

Short circuiting or reversing polarity may lead to serious damage to the batteries, the ChargeMaster, the cabling and/or the terminal connections. Fuses between the batteries and the ChargeMaster can not prevent damage caused by reversed polarity. The damage as a result of reverse polarity is detectable by the service department and is not covered by the warranty.



**CAUTION!**

Too-thin cables and/or loose connections can cause dangerous overheating of the cables and/or terminals. Therefore tighten all connections well, in order to limit transition resistance as far as possible. Use cables of the correct size.



**NOTE:**

If the battery temperature remains within 15-25°C, connection of the battery temperature sensor is optional.



**NOTE:**

The ChargeMaster is only feasible for the connection of MasterBus compatible remote control panels.

3.7.2 Connection example

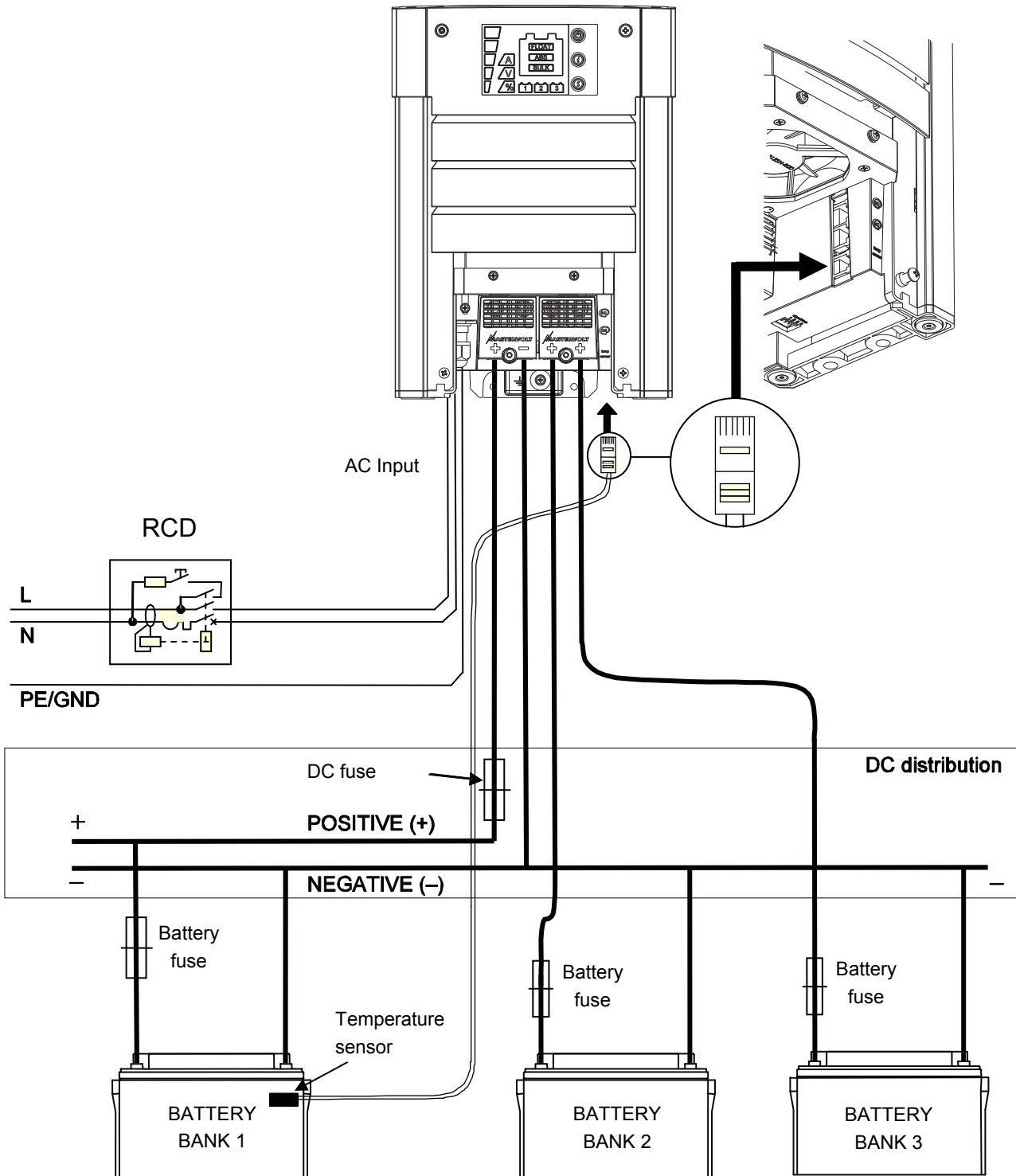

This schematic is to illustrate the general placement of the ChargeMaster in a circuit. It is not meant to provide detailed wiring instructions for any particular electrical installation.

Figure 7: Connection example of the ChargeMaster

**3.8 INSTALLATION STEP BY STEP**

**1** Mark the position of the four mounting spots by using the mounting bracket. Then fix the mounting bracket to the wall.

**2** Place the ChargeMaster over the mounting bracket and then move it downwards until it is suspended from the mounting bracket.

**3** Open the connection compartment by loosening the two screws.

**4** Fix the enclosure to the wall by fastening two screws at the lower side of the enclosure as well.

**5** Remove the isolation cap from the DC terminals. Fit crimp-on ring terminals to both DC-cables. Connect the DC-cablings of battery bank 1, positive to +, negative to - .

**6** Option: Connect the DC-wiring of the second and third battery bank. These battery banks should have a common negative with the main battery (see Figure 7).

**7** Mount the isolation caps of the DC terminals back into position. Mind the + and – markings!

**8** Attach the battery temperature sensor to the casing of battery bank 1. Plug the temperature sensor cable into the "temp.sensor" jack.

**9** Option: Connect the ChargeMaster to the MasterBus network. See APPENDIX.

**10** If required, change DIP-settings. See section 4.1 for adjustment. Use a small screw driver for adjustment of the DIP-switches.

**11** Check all wiring; see also Figure 7 for wiring details.

**12** Close the connection compartment by fixing the two screws.

**13** Connect the AC wiring. See section 3.3.2.

**14** Continue with section 3.9 for commissioning of the ChargeMaster.

## 3.9 COMMISSIONING AFTER INSTALLATION

### 3.9.1 General



If your ChargeMaster is not new, you have to take into account that former users may have changed the settings. Reset the ChargeMaster to Factory Settings when there is any doubt (see section 4.3.4).

The factory settings of the ChargeMaster are optimal for most installations. With some applications however, it is desirable to change these settings. Therefore several adjustments can be made. See chapter 4.



**NOTE:**  
The DIP-switches must be adjusted *prior* to commissioning; all other settings can only be made *after* commissioning.

### 3.9.2 Commissioning step-by-step



**CAUTION!**  
Check the polarity of all wiring before commissioning: positive connected to positive (red cables), negative connected to negative (black cables).

- 1 If all wiring is OK, place the DC-fuse(s) of the DC-distribution to connect the batteries to the ChargeMaster.



**WARNING**  
When placing this fuse, a spark can occur, caused by the capacitors used in the ChargeMaster. This is particularly dangerous in places with insufficient ventilation, due to the gassing of the batteries an explosion can occur. Avoid having flammable materials close by.

- 2 Switch on the AC power supply
- 3 Hold the POWER button (Figure 2) pressed for 5 seconds to switch on the charger

Now the ChargeMaster will initiate the charging process.

### 3.9.3 MasterBus (optional)

During first commissioning the ChargeMaster will be recognized by the MasterBus network automatically. The remote control panel of the MasterBus network will indicate that a new device was found.

Some settings can only be changed via the MasterBus interface. See section 4.3 for an overview of all available MasterBus settings. Refer to the user's manual of the remote control panel to change these settings.

### 3.10 DECOMMISSIONING

To put the ChargeMaster out of operation, follow these instructions in order of succession:

- 1 Switch the ChargeMaster to stand-by (see section 2.2).
- 2 Remove the DC-fuse(s) and disconnect the batteries.
- 3 Remove the AC-fuse(s) of the AC-input and/or disconnect the AC-mains.
- 4 Open the connection compartment of the ChargeMaster.
- 5 Check with a suitable voltage meter whether the inputs and the outputs of the ChargeMaster are voltage free.
- 6 Disconnect all the wiring.

Now the ChargeMaster can be demounted in a safe way.

### 3.11 STORAGE AND TRANSPORTATION

When not installed, store the ChargeMaster in the original packing, in a dry and dust free environment.

Always use the original packing for transportation. Contact your local Mastervolt Service Centre for further details if you want to return the apparatus for repair.

### 3.12 RE-INSTALLATION

To reinstall the ChargeMaster, follow the instructions as described in this chapter (chapter 3).

## 4 SETTINGS

Adjustment of the settings of the ChargeMaster can be made in two different ways:

- By means of DIP-switches; see section 4.1;
- Via the MasterBus network; see section 4.3.



### CAUTION!

Invalid settings of the ChargeMaster can cause serious damage to your batteries and/or the connected load! Adjustments of settings may be undertaken by authorised personnel only.

### 4.1 DIP SWITCH SETTINGS

The ChargeMaster has four DIP switches at the bottom side of the enclosure. See Figure 8.

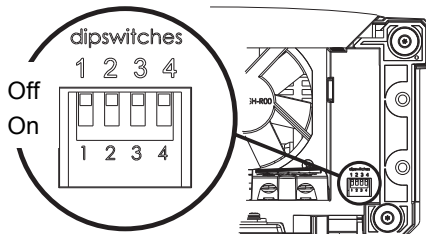

Figure 8: DIP switches

#### 4.1.1 DIP switch 1: Battery type

The factory default for the battery type is optimal for most installations. In some applications however, it is desirable to change this setting.

Flooded battery (factory setting)	OFF
Gel / AGM / spiral battery (see specifications)	ON

#### 4.1.2 DIP switch 2: Charge algorithm

IUoUo, fully automatic / 3step+ (factory setting)	OFF
Constant voltage charging (Float = 13.25/26.5V)	ON

#### 4.1.3 DIP-switch 3: Stand-by mode for display

Display will switch off when ChargeMaster is switched to stand-by mode (factory setting)	OFF
Display will stay on when ChargeMaster is switched to stand-by mode. Note that the display is powered by the batteries.	ON

#### 4.1.4 DIP switch 4: CEC Energy saving mode

Energy saving mode disabled (factory setting)	OFF
Energy saving mode enabled.	ON



The CEC Energy saving mode is only available on battery chargers that have the BC logo on the Identification label (see section 1.4)

The CEC Energy saving mode is used to meet the requirements of the California Energy Commission (CEC). When enabled, the charger switches to stand-by after finishing the Absorption phase of the three-step charge algorithm. This mode is applicable for battery charging systems in the USA only.

Minimum battery capacity to meet the requirements of the CEC regulations:

Model ChargeMaster	Battery capacity
12/35-3	>400Ah
12/50-3	>560Ah
24/20-3	>240Ah
24/30-3	>320Ah

## 4.2 EQUALIZE MODE



### WARNING

Incorrect use of the equalize mode may lead to hazardous situations.

Do not smoke; use any naked flame or other sources of ignition due to risk of explosion. Always ventilate the room where the batteries are located and equalized to clear the air.

Equalization is ONLY applicable for flooded type batteries and will damage gel, AGM and MLI type batteries.

An equalizing charge can be necessary after very deep discharges and/or inadequate charges. This has to be carried out according to the specifications of the manufacturer of the batteries.

During equalizing the batteries are brought into the gas state and it is possible that the permitted load voltages are exceeded. Therefore appropriate measures must be taken, e.g. disconnect all loads from the battery and ventilate the room. For these reasons use of the equalizing mode should only be executed by trained technical engineers.

The equalizing mode can only be started when the ChargeMaster is in operation and in Float mode. The equalize mode can only be started by means of MasterBus (see section 4.3.4).

### 4.3 MASTERBUS FUNCTIONS

Adjustment of the settings of the ChargeMaster can be made via the MasterBus network (by means of a remote control panel or an interface connected to a PC with MasterAdjust software).



See APPENDIX for more information about MasterBus.

#### 4.3.1 Monitoring

Value	Meaning	Factory setting	Adjustable range
<b>General</b>			
State	Shows charger state (Charging / Standby / Alarm)		(read only)
On/Stand-by	Button to toggle the charger state		On / Stand-by
Input current	Option to set the maximum AC input current to prevent a generator or shore fuse from overload situations	8.0A	0.0 – 8.0A
Charge State	Actual state of charge algorithm: Bulk/absorption/float		(read only)
Battery temp.	Actual temperature of the main battery bank (in °C)		(read only)
<b>Output</b>			
Charge current	Total output current of charge outputs 1, 2 and 3		(read only)
Output 1	Voltage of charge output 1		(read only)
Output 2	Voltage of charge output 2		(read only)
Output 3	Voltage of charge output 3		(read only)

#### 4.3.2 Alarm

Value	Meaning	Factory setting	Adjustable range
<b>Charger</b>			
Temp sense error	Battery temperature sensor is in short circuit		(read only)
Temp error	Battery temperature is out of range <-20°C (-4°F) or >55°C (131°F)		(read only)
Output high	DC output voltage is too high		(read only)
Output low	DC output voltage is too low		(read only)
MSH out of range	DC output voltage of the ChargeMaster differs more than 3.0V from the voltage measured by the Mastershunt		(read only)

#### 4.3.3 History

This menu shows the absolute maximum readings.

Value	Meaning	Factory setting	Adjustable range
<b>Charger</b>			
Ah charged	Total Ampere hours charged (Ah)		(read only)
Total run time	Total run time in charger mode (hours)		(read only)
Temp. Shutdown.	Number of temperature shutdowns		(read only)
Low DC Shutdown	Number of low DC voltage shutdowns		(read only)
High DC Shutdown	Number of high DC voltage shutdowns		(read only)
<b>Battery 1</b>			
Lowest DC volt	Lowest detected DC voltage output 1		(read only)
Highest DC Volt	Highest detected DC voltage output 1		(read only)
<b>Battery 2</b>			



Value	Meaning	Factory setting	Adjustable range
Lowest DC volt	Lowest detected DC voltage output 2		(read only)
Highest DC Volt	Highest detected DC voltage output 2		(read only)
<b>Battery 3</b>			
Lowest DC volt	Lowest detected DC voltage output 3		(read only)
Highest DC Volt	Highest detected DC voltage output 3		(read only)

#### 4.3.4 Configuration

Below parameters can be changed via the MasterBus network by means of a remote control panel or by means of an interface connected to a PC with MasterAdjust software. See applicable user's manuals for details.

Value	Meaning	Factory setting	Adjustable. range
<b>General</b>			
Language	Language that is displayed on a monitoring device connected to the MasterBus	English	EN, NL, DE, FR, ES, IT, NO, SV, FI, DA
Product Name	Name of this device. This name will be recognized by all devices connected to the MasterBus	CHG CM+type*	0-12 chars
Output 1	Name of the battery bank connected to charge output 1	Output 1	0-16 chars
Output 2	Name of the battery bank connected to charge output 2	Output 2	0-16 chars
Output 3	Name of the battery bank connected to charge output 3	Output 3	0-16 chars
Factory Settings	Reset to factory settings		(button)
<b>Charge current</b>			
Max. current	Setting of the maximum output current	$I_{max}$	1A - $I_{max}$
<b>Battery type</b>			
Battery type	Selection of pre-set charge algorithm. Individual adjustments of <i>Bulk</i> , <i>Absorption</i> and <i>Float</i> are only possible if "User defined" is selected here.	Flooded	Flooded, AGM, Gel, MLI, Flooded traction, User defined
<b>Mastershunt</b>			
Mastershunt	A connected MasterShunt can be chosen for feedback on the charged battery.	No connection	No connection, MSH + Product Name
<b>Bulk</b>			
Bulk voltage	Bulk voltage (@ 25°C); see section 2.4	14.40/28.80V	0-15.50/0-31.00V
Max. bulk timer	Maximum time of the Bulk phase since <i>Start bulk timer</i>	480 min	0-1440min
Min bulk timer	Minimum time of the Bulk phase since <i>Start bulk timer</i>	120sec	0-240sec
Start bulk timer	Battery voltage trigger point to start the bulk timer	13.25/26.50V	(read only)
<b>Absorption</b>			
Abs. voltage	Absorption voltage (@ 25°C); see section 2.4	14.25/28.50V	0-15.50/0-31.00V
Max absorp. time	Maximum absorption timer	240min	0-1440min
Min absorp. time	Minimum absorption timer	15min	0-240min
Return amps	Return amps. If the charge current drops below this level, the charger switches from the Absorption to the Float stage (% of $I_{max}$ )	6%	0-50%
<b>Float</b>			
Float voltage	Float voltage (@ 25°C); see section 2.4	13.25/26.50V	0-15.50/0-31.00V
Constant voltage	Charge voltage (@ 25°C) if the charger is set to the Constant voltage charging (2-Step) mode; see section 4.1	13.80/27.60V	0-15.50/0-31.00V
Return to bulk	Return to bulk voltage; If the battery voltage stays below this level for at least the <i>Return to bulk delay time</i> , the charger will start the Bulk stage	12.80/25.60V	0-15.50/0-31.00V
Return to bulk	Return to bulk delay time, see <i>Return to bulk voltage</i>	30sec	0-240sec
<b>Alarms</b>			
DC High on	Upper threshold level to trigger the Output high alarm	16.00/32.00V	0-16.00/0-32.00V

Value	Meaning	Factory setting	Adjustable. range
DC High off	Lower threshold level to stop the Output high alarm	15.50/31.00V	0-16.00/0-32.00V
DC Low on	Lower threshold level to trigger the Output low alarm	10.00/20.00V	0-16.00/0-32.00V
DC Low off	Upper threshold level to stop the Output low alarm	11.00/22.00V	0-16.00/0-32.00V
Alarm Delay	Delay time to trigger the Output low alarm	30sec	0-240sec
<b>Equalization</b>			
Equalize voltage	Voltage compensation for Equalize charging	+2.25/+4.50V	0 - +2.25/+4.50V
Max equalize tim	Max equalize timer	240min	0-1440min
Equalize mode	Shows whether the Equalize mode is active ("On") or not ("Off")		(read only)
Equalize	Button to start the equalize mode manually See section 4.2. The equalize mode can only be started when the charger is in the Float stage.		Button
<b>Dip switches</b>			
Battery type	Readout of DIP switch 1 (see section 4.1)	Flooded	(read only)
Charge algorithm	Readout of DIP switch 2 (see section 4.1)	3step	(read only)
Display mode	Readout of DIP switch 3 (see section 4.1)	Off	(read only)

\* Depending on model CM12/35, CM12/50, CM24/20, CM24/30

**4.3.5 Events**

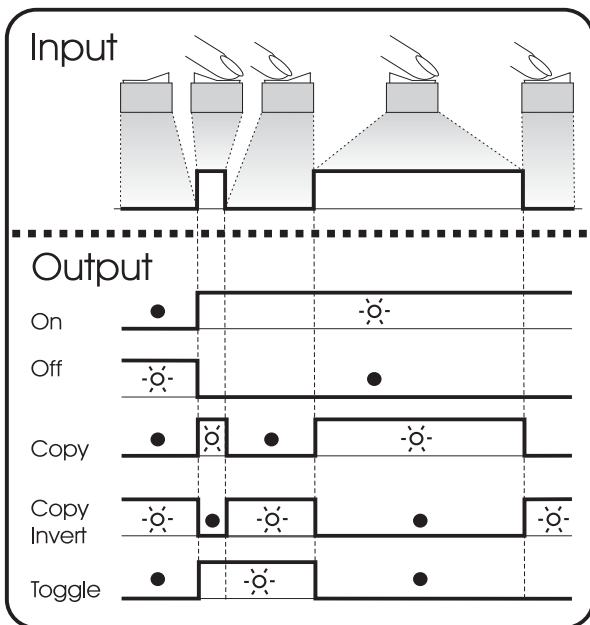

Figure 12 shows the meaning of the event data.

**Input (pulses)**

The input is represented by an on/off switch.

**Output (data)**

**On** changes the status to On at the first signal.

**Off** changes the status to Off at the first signal.

**Copy** lets the status follow the input.

**Copy Invert** lets the status follow the opposite of the input

**Copy** is used for dimming too by holding the pulse switch

pressed for a longer time.

**Toggle** changes the status at the first signal and back at the second signal. It is used in combination with a pulse switch.

Figure 12: Event data

Value	Meaning	Factory setting	Adjustable. range
<b>Events</b>			
Event x source	<i>Event-based command</i> Event by the ChargeMaster that should result in an action by another device on the <i>MasterBus</i> network.	Disabled	(See List of event sources, section 4.3.6)
Event x target	<i>Event-based command</i> Selection of device on the <i>MasterBus</i> network that should take action due to an event by the ChargeMaster.		(See Device list)
Event x command	<i>Event-based command</i> Action to be taken by the selected device.		(See <i>List of event commands</i> in the manual of the selected device.)
Event x data	<i>Event-based command</i> Value of the action to be taken by the selected device.		(See <i>List of event commands</i> in the manual of the selected device.)
Event x+1	The next event appears after enabling Event x.	Disabled	See Event x.

### 4.3.6 List of list of events sources (ChargeMaster as event source)

Below the list of event sources of the *ChargeMaster* is shown. These event sources can be used to initiate an event command and an event action at another device that is connected to the *MasterBus*.

Event source	Description
Not used	(no event programmed)
On	ChargeMaster state is On
Bulk	State of charge is Bulk
Absorption	State of charge is Absorption
Float	State of charge is Float
Failure	Charger failure <i>MasterBus</i> alarm
LED 1	Bottom yellow LED of the <i>MasterView Read Out</i> illuminates (see manual <i>MasterView Read Out</i> )
LED 2	2nd yellow LED from bottom of the <i>MasterView Read Out</i> illuminates (see manual <i>MasterView Read Out</i> )
LED 3	3rd yellow LED from bottom of the <i>MasterView Read Out</i> illuminates (see manual <i>MasterView Read Out</i> )
LED 4	4th yellow LED from bottom of the <i>MasterView Read Out</i> illuminates (see manual <i>MasterView Read Out</i> )
LED 5	Top yellow LED of the <i>MasterView Read Out</i> illuminates (see manual <i>MasterView Read Out</i> )
Fan	Fan of the charger is on

### 4.3.7 List of list of event commands (ChargeMaster as event target)

Below the list of event commands and event data of the *ChargeMaster* is shown. Other devices connected to the *MasterBus* can be programmed to initiate these commands and actions at the *ChargeMaster*.

Event command	Description
State	Command to switch on the ChargeMaster
Bulk	Command to start the Bulk state of charge
Abs	Command to start the Absorption state of charge
Float	Command to start the Float state of charge

## 5 TROUBLE SHOOTING

If you cannot solve a problem with the aid of this chapter, contact your local Mastervolt Service Centre. Make sure you have the following information present if you have to contact your local Mastervolt Service Center to solve a problem:

- Article and serial number; see section 1.4
- Firmware version; double click on ChargeMaster icon in MasterView System software Configuration.

Malfunction	Possible cause	What to do
No output voltage and/or current	No AC-input	Check AC wiring, check remote control panel.
	AC-input voltage too low (< 90VAC)	Check input voltage, check generator.
	AC input frequency out of range	Check input voltage, check generator.
Output voltage too low, charger supplies maximum current	Load that is connected to the batteries is larger than charger can supply.	Reduce load taken from the batteries.
	Batteries not 100% charged	Measure battery voltage. After some time this will be higher.
	Wrong setting of the charge voltage	Check settings (see chapter 4).
Charge current too low	Batteries almost fully charged	Nothing, this is normal when the battery is almost fully charged.
	High ambient temperature	Nothing; if ambient temperature is more than the setting limit the charge current is automatically reduced.
	Low AC input voltage. At lower AC input voltages the charge current is reduced. See APPENDIX .	Check AC-input voltage.
Batteries not fully charged	Charge current too low	See "Charge current too low" in this table.
	Current to load is too high	Reduce load taken from the batteries.
	Charge time too short	Use a battery charger with higher capacity.
	Battery temperature too low	Use the battery temperature sensor.
	Defective or old battery	Check battery and replace if necessary.
Batteries are discharged too fast	Wrong setting of the charge voltage	Check settings (see chapter 4).
	Battery capacity reduced due to wastage or sulphation, stagnation	Charge and recharge a few times, this might help. Check battery and replace if necessary.
Batteries are too warm, gassing	Defective battery (short circuit in cell)	Check battery and replace if necessary.
	Battery temperature too high	Use the battery temperature sensor.
	Charge voltage too high	Check settings (see chapter 4).
No MasterView display function.	Display is switched off.	Switch on display, refer to display manual.
	Error in the wiring.	Check the MasterBus cables.
Slow or no MasterBus communication.	Error in the MasterBus wiring.	Check the MasterBus cables.
	No terminating device placed at the ends of the network.	MasterBus needs a terminating device on both ends of the network. Check if connected.
	MasterBus network is configured as a ring network.	Ring networks are not allowed. Check the connections of the network.

## 6 TECHNICAL DATA

### 6.1 SPECIFICATIONS 12V MODELS

Model	12/35-3	12/50-3
Article no.	44010350	44010500
<b>GENERAL</b>		
Nominal input voltage**:	120/230V	120/230V
Nominal input frequency:	50/60Hz	50/60Hz
Full load consumption:	575VA	825VA
Efficiency at full load (230V AC):	≥81% @ 230V input	≥81% @ 230V input
Nominal output voltage:	12V	12V
Total maximum charge current (I <sub>max</sub> ):*	35A at 14.4V	50A at 14.4V
Number of battery outputs:	3	3
Output voltage range adjustable	0 to 16V DC	0 to 16V DC
Charge characteristic*:	IUoUo, automatic, three step plus	
Charge voltage Bulk*:	14.4V (MLi: 14.6V)	14.4V (MLi: 14.6V)
Charge voltage Absorption*:	14.25V (MLi: 14.6V)	14.25V (MLi: 14.6V)
Charge voltage Float*:	13.25V (AGM, gel: 13.8V, MLI: 13.5V)	13.25V (AGM, gel: 13.8V, MLI: 13.5V)
Max. absorption and max. bulk timer*:	8 hours (start max. bulk timer at 13.25V)	
Minimum absorption time*:	15 min.	15 min.
Maximum ripple voltage on DC	100mV pp	100mV pp
Battery type settings*:	Flooded / gel / AGM / spiral / MLI (adjustable by means of DIP-switch or MasterBus)	
Dimensions in mm (inch):	291x210x131 (11.5x8.3x5.2)	291x210x131 (11.5x8.3x5.2)
Weight:	4kg (9Lbs)	4kg (9Lbs)
Recommended battery capacity:	70-350Ah	100-500Ah
Power factor regulations	≤ 0.99	≤ 0.99
Temperature compensation	Battery temperature sensor and cable included.	
Voltage compensation	Yes, by means of automatic compensation.	
DC consumption, display OFF ***	<5mA	<5mA
DC consumption, display ON ***	130mA	130mA
Temperature range	-25°C (-13°F) to 65°C (149°F). de-rating 3%/°C (2%/°F) above 40°C (104°F), 90% de-rating under 0°C (32°F)	
Cooling	Vario fan and natural cooling to ensure optimized cooling when unit stored in corners etc.	
Sound level	<52dBA / 1m	<52dBA / 1m
Protection degree	IP23	IP23
MasterBus connectivity	Yes	Yes
Powering capabilities for MasterBus	Yes, when the charger is switched on, it can power up to three non-powering devices.	
MasterBus languages available	EN, NL, DE, FR, ES, IT, NO, SV, FI, DA	

\* Adjustable, see chapter 4 for settings.

\*\* See also APPENDIX for AC input characteristics

\*\*\* See section 4.1.3 for settings

Specifications are subject to change without prior notice.

**6.2 SPECIFICATIONS 24V MODELS**

<b>Model</b>	<b>24/20-3</b>	<b>24/30-3</b>
Article no.	44020200	44020300
<b>GENERAL</b>		
Nominal input voltage**:	120/230V	120/230V
Nominal input frequency:	50/60Hz	50/60Hz
Full load consumption:	660VA	925VA
Efficiency at full load:	≥83% @ 120V input	≥85% @ 230V input
Nominal output voltage:	24V	24V
Total maximum charge current*:	20A at 28.8V	30A at 28.8V
Number of battery outputs:	3	3
Output voltage range adjustable	10-32VDC	10-32VDC
Charge characteristic*:	IUoUo, automatic, three step plus charging method	
Charge voltage Bulk*:	28.8V (MLi: 29.2V)	28.8V (MLi: 29.2V)
Charge voltage Absorption*:	28.5V (MLi: 29.2V)	28.5V (MLi: 29.2V)
Charge voltage Float*:	26.5V (AGM, gel: 27.6V, MLI: 27.0V)	26.5V (AGM, gel: 27.6V, MLI: 27.0V)
Max. absorption and max. bulk timer*:	8 hours (start of the maximum bulk timer at 26.5V)	
Minimum absorption time*:	15 min.	15 min.
Maximum ripple voltage on DC	200mV pp	200mV pp
Battery type settings*:	Flooded / gel / AGM / spiral / MLI (adjustable by means of DIP-switch or MasterBus)	
Dimensions in mm (inch):	291x210x131 (11.5x8.3x5.2)	291x210x131 (11.5x8.3x5.2)
Weight in kg (pound):	4kg (9Lbs)	4kg (9Lbs)
Recommended battery capacity:	40-200Ah (see section 3.4)	60-300Ah (see section 3.4)
Power factor regulations	≤ 0.99	≤ 0.99
Temperature compensation	Battery temperature sensor and cable included.	
Voltage compensation	Yes, by means of automatic compensation.	
DC consumption, display OFF ***	<2.5mA	<2.5mA
DC consumption, display ON ***	130mA	130mA
Temperature range	-25°C (-13°F) to 65°C (149°F). De-rating 3%/°C (2%/°F) above 40°C (104°F), 90% de-rating under 0°C (32°F)	
Cooling	Vario fan and natural cooling optimize cooling when unit stored in corners etc.	
Sound level	<52dBA / 1m	<52dBA / 1m
Protection degree	IP23	IP23
MasterBus connectivity	Yes	Yes
Powering capabilities for MasterBus	Yes, when the charger is switched on, it can power up to three non-powering devices.	
MasterBus languages available	EN, NL, DE, FR, ES, IT, NO, SV, FI, DA	

\* Adjustable, see chapter 4 for settings.

\*\* See also APPENDIX for AC input characteristics

\*\*\* See section 4.1.3 for settings

Specifications are subject to change without prior notice.



## 7 ORDERING INFORMATION

### 7.1 MASTERBUS INSTALLATION COMPONENTS

Part number	Description
77040000	MasterBus terminating device
77040020	MasterBus connection cable (UTP patch cable), 0,2m / 0.6ft
77040050	MasterBus connection cable (UTP patch cable), 0,5m / 1.6ft
77040100	MasterBus connection cable (UTP patch cable), 1,0m / 3.3ft
77040300	MasterBus connection cable (UTP patch cable), 3,0m / 10ft
77040600	MasterBus connection cable (UTP patch cable), 6,0m / 20ft
77041000	MasterBus connection cable (UTP patch cable), 10m / 33ft
77041500	MasterBus connection cable (UTP patch cable), 15m / 49ft
77042500	MasterBus connection cable (UTP patch cable), 25m / 82ft
77050100	100m / 330ft MasterBus cable (UTP cable)
77050200	50 pcs. modular jacks
77050000	Complete set to assemble UTP patch cables. Delivery includes: 100m / 330ft UTP cable, 50 pcs. modular jacks and crimping tool
77030100	MasterConnect USB interface, required as interface between your PC and the MasterBus when using MasterAdjust software.
77010305	MasterView Easy MkII, Touch screen to control and monitor all MasterBus products
77010400	MasterView System, Full-colour touch screen to control and monitor all MasterBus products
77020100	MasterShunt 500, DC-distribution module for exact readout of battery voltage, charge / discharge current, and state of charge on the display of the ChargeMaster. continuous rating: 250A, peak current: 500A

### 7.2 MISCELLANEOUS

Part number	Description
6384003200	Industrial DC fuse 32A DIN 00
6384004000	Industrial DC fuse 40A DIN 00
6384006300	Industrial DC fuse 63A DIN 00
6381001000	Fuse base DIN 00 (max. 160A)
701	Battery switch 275A with knob
6387000600	Double pole automatic circuit breaker DPN 6A-B, 1P+N
6387001000	Double pole automatic circuit breaker DPN 10A-B, 1P+N
6387001600	Double pole automatic circuit breaker DPN 16A-B, 1P+N
6385401610	Double pole automatic circuit breaker and earth leakage switch DPN VIGI 16A / B / 16mA, 1P + N
41500500*	Battery temperature sensor, incl. 6 meter / 19 ft cable

\* standard included with the delivery of the ChargeMaster

Mastervolt can offer a wide range of products for your electrical installation, including an extended program of components for your MasterBus network, both AGM and gel batteries, shore power connections, DC distribution kits and many more.

