

MASTERVOLT

THE POWER TO BE INDEPENDENT

Mass GI

Isolation transformer 3.5 / 7.0



USER AND INSTALLATION MANUAL

10000012135/04

CE

1. Safety instructions



CAUTION!

Read the entire manual before using the Mass GI. Keep this manual in a secure place.

- Use the Mass GI following the instructions and specifications stated in this manual.
- Connections and safety features must be executed according to locally applicable regulations.
- Operation of the Mass GI without proper grounding may lead to hazardous situations!
- Use cables with an appropriate size.
- Never use the Mass GI in situations where there is danger of gas or dust explosion or potentially flammable products!
- Never open any other part of the housing than the connection compartment. High voltages may be present inside!
- Always disconnect the AC-input before you open the connection compartment.
- The Mass GI must be provided with an equipment-grounding to the AC-input ground terminal.
- Always connect a dedicated double pole circuit breaker and Ground Fault Circuit Interrupter (GFCI) / Residual-Current Device (RCD) at the input of the Mass GI.
- Only use the Mass GI in a technical correct condition.
- Only use the Mass GI in a well-ventilated room and protected against rain, moist, dust and condensation. Do not obstruct the ventilation openings.
- The Mass GI is not sold for life support applications without written permission by Mastervolt.

2. Liability

Mastervolt cannot be held liable for:

- Consequential damage resulting from the use of the Mass GI.
- Possible errors in the included manual and the consequences of these.
- Use that is inconsistent with the purpose of the product.

3. Disclaimer

Our products are subject to continual development and improvement. Therefore, additions or modifications to the products may cause changes to the technical data and functional specifications. No rights can be derived from this document. Please consult our most current Terms & Conditions of Sale.

4. Warranty

Mastervolt assures the product warranty of the Mass GI during two years after purchase, on the condition that the product is installed and used according to the instructions in this manual.

Installation or use not according to these instructions may result in under performance, damage or failure of the product and may void this warranty. The warranty is limited to the cost of repair and/or replacement of the product. Costs of labour or shipping are not covered by this warranty.

5. Correct disposal of this product

(Waste Electrical & Electronic Equipment)



This product is designed and manufactured with high quality materials and components, which can be recycled and reused. When this crossed-out wheeled bin symbol is attached to a product, it means the product is covered by the European Directive 2012/19/EU.

Please be informed about the local separate collection system for electrical and electronic products. Please act according to your local rules and do not dispose of your old products with your normal household waste. The correct disposal of your old product will help prevent potential negative consequences to the environment and human health.

6. Product description

The Mass GI is an isolation transformer for galvanic isolation between AC shore-power and the onboard AC electrical system. This prevents galvanic corrosion of metal parts of the ship when grounding is present. The Mass GI is available in two versions: 3.5kW (16A) and 7.0kW (32A).

The input circuit of the Mass GI is equipped with a soft start circuit to eliminate high inrush currents. If 3.5kW of shore power is not sufficient, more Mass GIs can be connected in parallel to increase the power up to 14kW maximum.

Dimensions

Mass GI 3.5 / 7.0

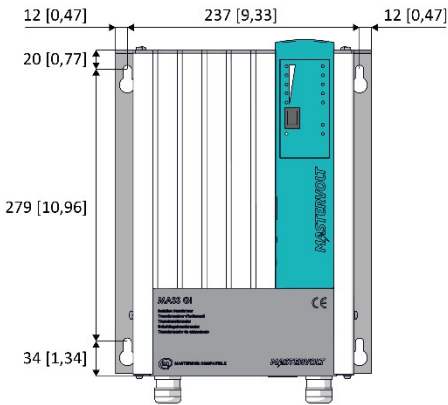

Mass GI 3.5

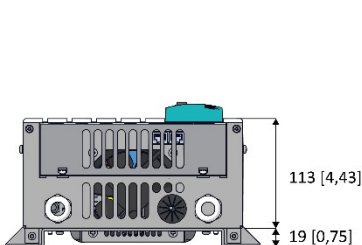

Mass GI 7.0

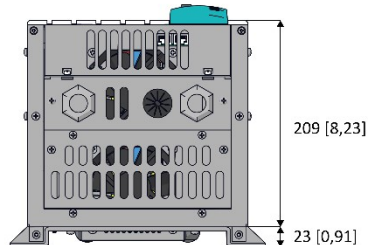

Mass GI 3.5

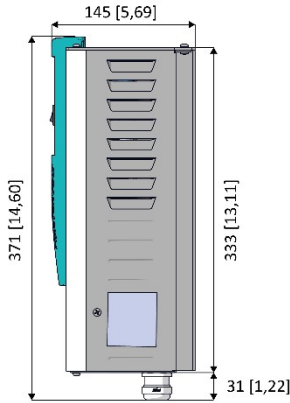

Mass GI 7.0

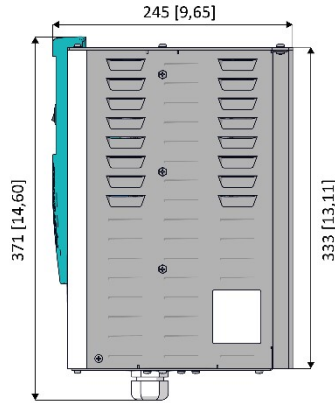

Exterior

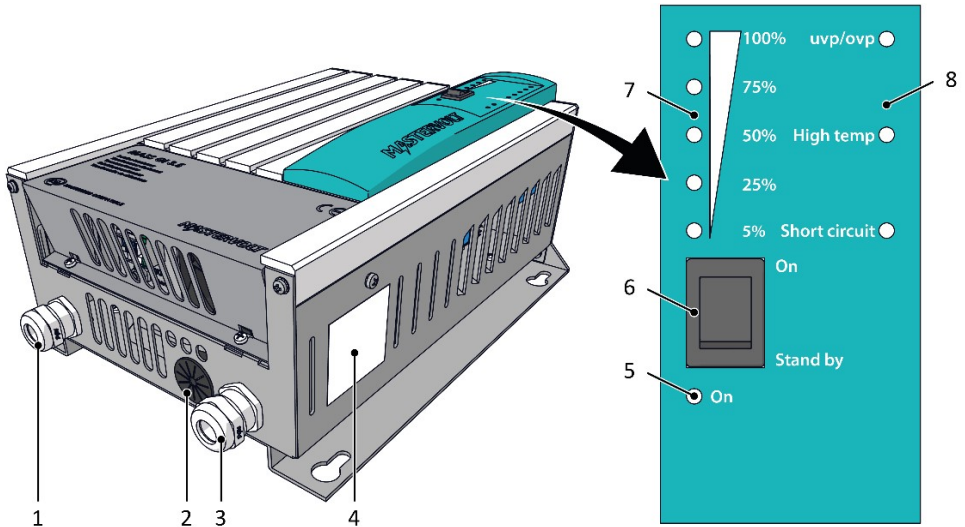

Exterior

- | | |
|---|-------------------------------|
| 1 | Cable gland for input |
| 2 | Grommet for MasterBus cabling |
| 3 | Cable gland for output |
| 4 | Identification label |
| 5 | Status LED On/Off |
| 6 | Main switch |
| 7 | Status LEDs load |
| 8 | Status LEDs failure |

Interior

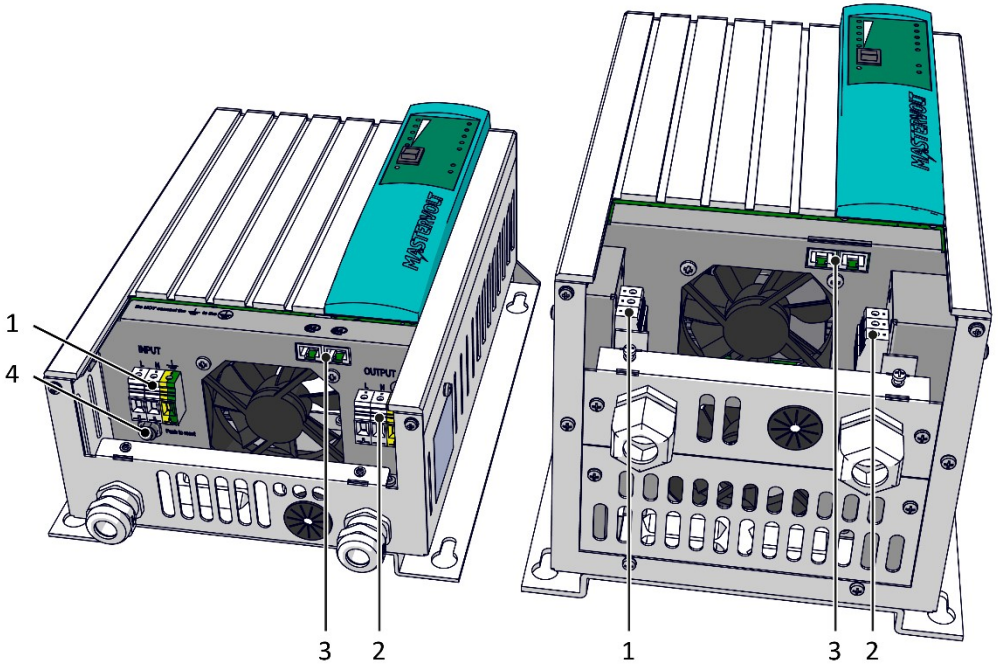

Interior		
1	Input terminal	AC input Line AC input Neutral Earth
2	Output terminal	AC output Line AC output Neutral Protective Earth
3	MasterBus connectors	
4	Resettable fuse 20AT (Mass GI 3.5 only)	



WARNING!

Never connect Earth (input) to Protective Earth (output).

MasterBus

The Mass GI can communicate with the MasterBus network. This network can be used for remote control and remote (alarm) monitoring of the Mass GI, for configuration (in parallel) and for communication with other system devices. See chapters 9 and 10 for more information.

Protection

The Mass GI is protected against overload, peak current, short circuit and high temperature (see table). See chapter 8 for LED indications if a protection comes into effect.

Protection	
Type of protection	Description
Overload protection 16A	An integrated electronic fuse limits the input current to 16A. This fuse will switch the Mass GI to Standby in overload situations and trigger the MasterBus alarm. See Chapter 8 for restore instructions.
Overload protection 20AT	A 20AT fuse switches off the input without triggering a MasterBus alarm. See Chapter 8 for reset instructions.
Peak current limitation	The Mass GI is automatically protected against a peak current during a short period.
Short circuit protection	An electronic fuse trips when during 1 second short circuit conditions are met. In case of short circuit, the Mass GI switches to Standby, the short circuit LED illuminates and the MasterBus alarm is triggered.
Thermal protection	The Mass GI is protected against high temperature by 3 integrated thermal fuses. If one of these fuses trips, the Mass GI will switch to Stand by, the high temperature LED illuminates and the MasterBus alarm is triggered.

Identification label



7. Installation

In this chapter we describe the installation of the Mass GI. Follow these instructions for both stand-alone and parallel use. Refer to chapter 11 for more information on creating systems with multiple units in parallel for shore connections of more than 16A.

Unpacking

The delivery consists of the following parts:

- Mass GI
- MasterBus cable (in connection compartment or in the box)
- MasterBus terminator (in connection compartment or in the box)
- User manual. Store this manual at a secure place!

After unpacking, check the Mass GI for possible damage. Never use a damaged Mass GI. If in doubt, contact your supplier or Mastervolt.

Choosing a location to install

Install the Mass GI in a well-ventilated room protected against rain, snow, spray, vapour, bilge, moisture and dust.

Ambient temperature: 0 – 40°C / 32 – 104°F.

Never use the Mass GI at a location where there is danger of gas or dust explosions.

Mount the Mass GI in such a way that obstruction of the airflow through the ventilation openings is prevented. No objects must be located within a distance of 10 cm / 4 inch around the Mass GI.

Do not install the Mass GI in the same compartment as the batteries. Do not mount the Mass GI straight above the batteries because of possible corrosive sulphur fumes.

Always mount the Mass GI vertically, this means with the cable glands facing downwards. Only in this position the Mass GI will deliver the IP degree protection as indicated in the specifications.

Recommended wire sizes

Recommended wire sizes AC		
Model	Minimum cross section (mm ² /AWG)	
Mass GI 3.5 (0-16A)	2,5mm ²	AWG13
Mass GI 7.0 (16-35A)	6,0mm ²	AWG8

Before you start

Make sure that the output of the supplying source is switched off during the entire installation.

Make sure the main switch is set to the Standby position.

Do not connect the AC-output of the Mass GI to an incoming AC source.



CAUTION!

Make sure that a MasterBus terminator remains plugged in one of the MasterBus connectors in case you use a Mass GI 7.0 without MasterBus. Otherwise the Mass GI 7.0 will not operate.

Mounting

Fix four M8 screws with rings on the wall. See Chapter 6 for dimensions. Place the unit and fasten the screws.

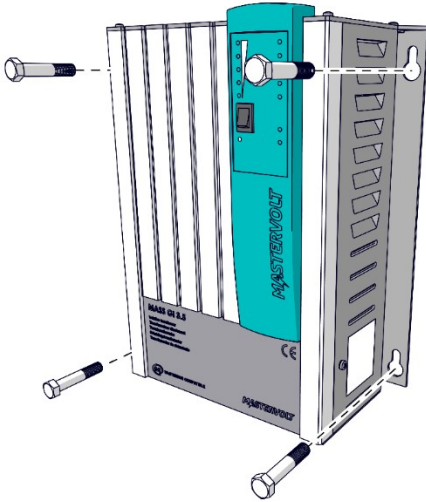

Opening the connection compartment



WARNING!

Never open the connection compartment when the Mass GI is connected to a power source. Loosen the two screws and remove the cover.

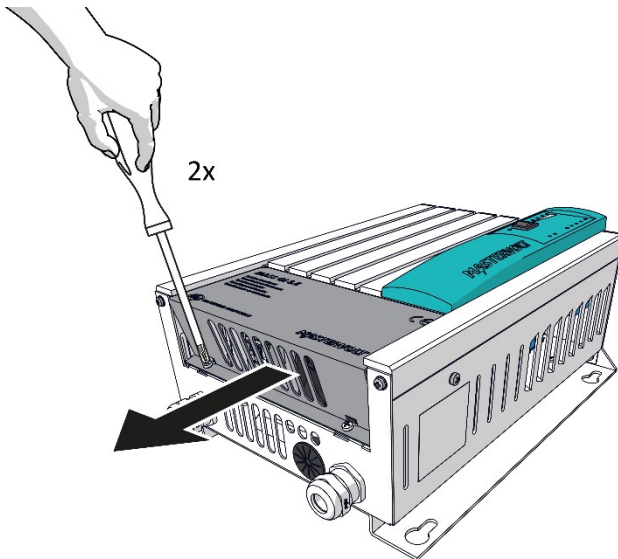

Wiring

Always first feed the wiring through the cable glands of the cabinet, and then connect the wiring to the terminals. Cut the wiring as shown in the following figures. Strip the conductors for 8mm.



The diameter of the outer isolation must be between 10 and 14mm to fit in the cable glands correctly enabling strain relieve.

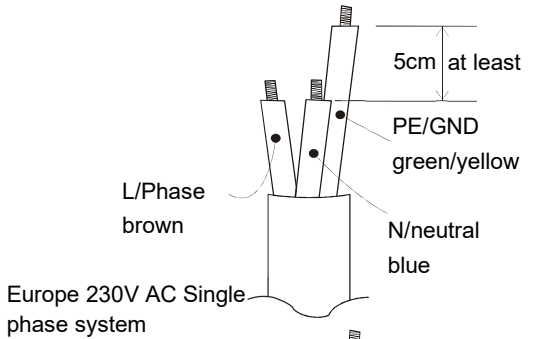

Europe 230V AC Single phase system

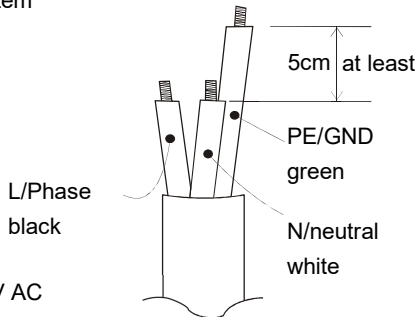

USA 120V AC Single phase system

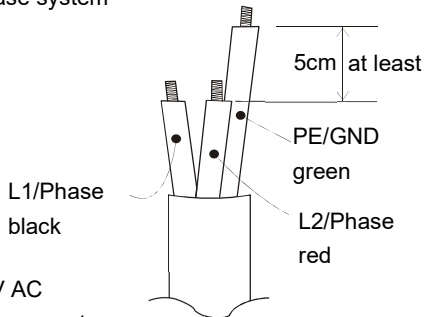

USA 240V AC Double phase system

Neutral grounding

For safe installation:

The Protective Earth (output terminal) must be connected to the central grounding point of the vehicle/ ship.

The neutral conductor (N) of the AC output of the Mass GI must be connected to the safety ground (PE/GND) and a ground fault circuit-interrupter (GFCI) must be integrated in the wiring of the AC output.

Always refer to locally applicable regulations on this topic!



WARNING!

Never connect Earth (input terminal) to Protective Earth (output terminal)!

Installation drawing

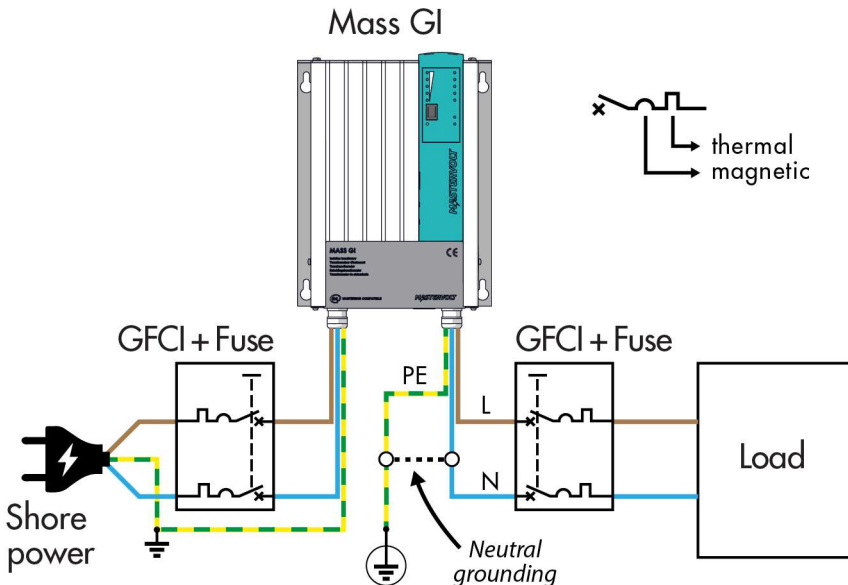

GFCI and Fuse sizes

Model	GFCI	Fuse
Mass GI 3.5	30mA	16A
Mass GI 7.0	30mA	32A

Commissioning

1. Tighten all cable glands to ensure the strain relief.
2. Check all wiring and connections.
3. Close the front cover plate of the connection compartment. Beware that the cabling does not obstruct the cooling fan and air flow.
4. Connect power to the Mass GI.
5. Switch On the Mass GI.
6. Check the Status LED On/Off and ensure that failure LEDs are Off. In case of failure, disconnect shore power and check Mass GI.

8. Operation

The Mass GI can be activated by switching the main switch to the “ON” position. When no error is present, the LED illuminates after this (green). The Mass GI will then generate an AC output voltage. Move the switch to the Standby position to switch off the Mass GI. In standby the Mass GI remains connected to the AC mains!

If a failure occurs, the Mass GI can be reset.

Reset the Mass GI

1. Set the main switch to Standby.
2. Switch On again.

Reset the 20AT fuse (Mass GI 3.5 only)

1. Move the main switch of the Mass GI to the Standby position.
2. Disconnect the Mass GI from any power source. Disconnect all loads from the Mass GI.
3. Investigate the cause of failure of the resettable fuse like overload or short-circuits.
4. Open the connection compartment.
5. Reset the 20AT fuse by pushing the button inside the connection compartment.
6. Close the connection compartment again.
7. Connect the Mass GI to the power sources.
8. Switch on the Mass GI.

If the fuse trips again in short time, please contact your Mastervolt supplier for service.

At the Mass GI 7.0 the fuse is located inside the device. Therefore corrections can only be performed by qualified technicians.

Maintenance

No specific maintenance is required. If necessary, use a soft clean cloth to clean the Mass GI. Never use any liquids or acids.

For reliable and optimum function examine your electrical installation on a regular base, at least once a year. Defects such as loose connections, burnt wiring etc. must be corrected immediately.

LED indicators

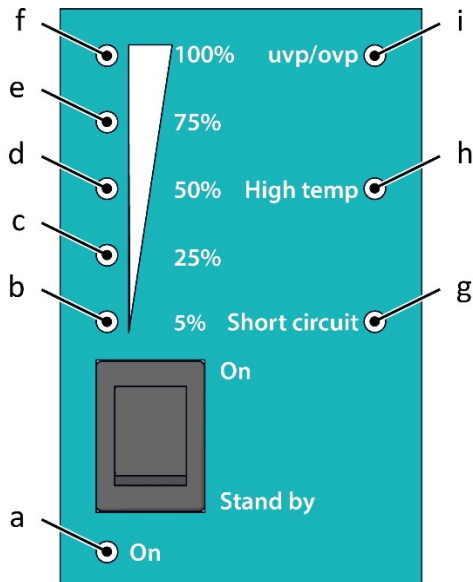

LED indicators

LED indication	Status	Meaning
a	On/Off	Mass GI is switched on.
a (blinking)	Waiting	Mass GI waits for parallel units to switch on.
a+b	Normal	Current conversion: 5% of nominal current.
a+b+c	Normal	Current conversion: 25% of nominal current.
a+b+c+d	Normal	Current conversion: 50% of nominal current.
a+b+c+d+e	Normal	Current conversion: 75% of nominal current.
a+b+c+d+e	Normal	Current conversion: 100% of nominal current.
+f (yellow)		
a+b+c+d+e +f (red)	Overload	Current conversion: >100% of nominal current, Mass GI will be shut off soon due to overload.
f (red)	Failure mode	Mass GI has been shut off due to overload.
g	Failure mode	Mass GI has been shut off due to short circuit.
h	Failure mode	Mass GI has been shut off due to too high temperature.
i	Failure mode	Mass GI has been shut off due to too low or too high input voltage.
i (blinking)	Failure mode	Mass GI has been shut off due to a frequency error on the input.

9. MasterBus



About MasterBus

All devices that are compatible with MasterBus are marked with the MasterBus symbol.

MasterBus is a CAN based, fully decentralized data network for communication between Mastervolt devices. MasterBus is used as power management system for all connected equipment, such as the inverter, battery charger, generator and many more.

Every device that is compatible with MasterBus is equipped with two data ports. The devices are simply chained together, forming a local data network. Monitoring panels such as the EasyView 5 can be used for monitoring and control of all connected MasterBus equipment.



CAUTION!

Never connect a non-MasterBus device to the MasterBus network directly! This will void warranty of all MasterBus devices connected.

Event based commands

With MasterBus a device can be programmed to initiate an action at another connected device. This is done by means of *event based commands*.

How to set up a MasterBus network

- Connections between the devices are made by standard straight MasterBus cables. Mastervolt can supply these cables. These (CAT5) cables are also commonly available at computer supply stores.
- Up to 63 MasterBus devices can be connected together.
- MasterBus needs a terminating device on both ends of the network.
- The electric power for the network comes from the connected devices according to the rule: 1 powering / 3 non powering.
- Do not make ring networks.
- Do not make T-connections in the network.

10. MasterBus on the Mass GI

Monitoring

The Monitoring tab displays the current State, Output and Shore conditions. Possible State conditions are: OK, No shore, Overload, Short circuit. See chapter 13 for maximum values. The Reset button will restart the unit.

The Monitoring interface consists of three panels:

- State Panel:** Shows 'State' as 'No shore'. Below it is a 'Shore fuse' dropdown menu set to '10A' and a 'Reset' button.
- Output Panel:** Displays three 'Output' readings: '0,0 V', '0,0 A', and '0,0 kW'.
- Shore Panel:** Displays five 'Shore' readings: 'cos phi -0,38', '0,0 V', '0,0 A', '0,0 kW', and '0 Hz'.

Alarm

The Alarm configuration panel includes the following options:

- Voltage high
- Temperature high
- Short circuit
- Overload shutdwn
- Low voltage
- Frequency fail
- Shore fuse >80%
- Shore fuse >100%
- Shore fuse >120%

Configuration

The Configuration interface is divided into three sections:

- General:** 'Language' dropdown set to 'English'; 'Device name' text field containing 'Mass GI 3.5'.
- Reset:** A 'Reset setup' button.
- Parallel:** 'Parallel setting' dropdown menu set to 'Single device'.

Reset setup resets the Mass GI to factory settings.

Events

The Events configuration panel shows 'Event 1 source' with a dropdown menu. The menu is open, showing the following options:

- Disabled (selected)
- Output
- LED: 5%
- LED: 25%
- LED: 50%
- LED: 75%
- LED: 100%
- LED: Overload
- MPC >80%
- MPC >100%
- MPC >120%
- Fan on
- Failure mode

History

Shore Shore 00:00:00	No shore No shore 00:13:19	Latest alarms Latest 0
Energy 0,0 kWh	Total Run time 1455d:17hr	Alarm No failure
Maximum 0,0 A	Energy 2816,0 kWh	Shore 209,6 V
Average --- A	Average 1,3 A	Output 0,0 V
Maximum 0,0 V		Output 0,0 A
Average --- V		
Minimum 0,0 V		
<input type="button" value="Reset"/>		

Event target

The Mass GI event based command (restart the Mass GI) can be triggered by other devices within the MasterBus network. See the relevant product manual for more information on this subject.

Events		
Event 1 source <input type="text" value="Toggle"/>	Event 1 target <input type="text" value="ISO Mass GI"/>	Event 1 command <input type="text" value="Reset"/>

11. Parallel systems

For connections of more than 16A (32A), multiple Mass GIs can be used in parallel (maximum four Mass GI 3.5 or two Mass GI 7.0).



WARNING!

Always follow the default installation instructions, as described in Chapter 6.



CAUTION!

In parallel, all inputs must be connected to the same phase.



WARNING!

Never connect the output(s) to any other power source.



NOTE

To achieve maximum performance all input and output wiring must be of equal length.

To create a parallel system

1. Connect the MasterBus cable between the communication ports on the Mass GIs. Note that MasterBus needs terminating devices on the network.
2. Connect the AC load to the AC output on the units.
3. Connect the incoming power to the AC input on your Mass GIs. Phase line to L, Neutral to N, and Ground to PE.

Parallel configuration is done automatically via MasterBus communication. When two, three* or four* units are detected in a MasterBus network, the system assumes that these operate in parallel.

* Mass GI 3.5 only

Installation drawing

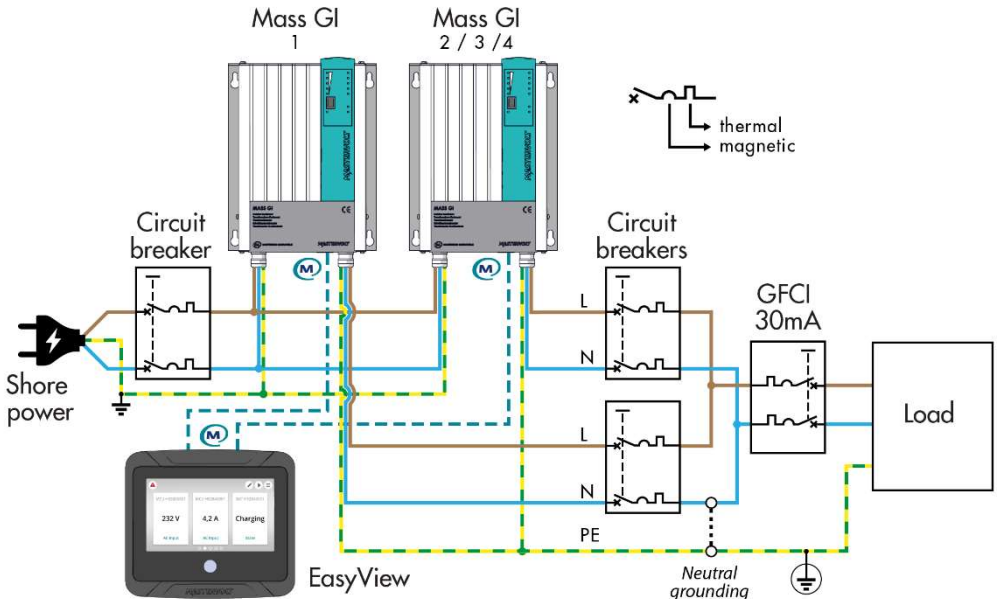

Safety devices in parallel configuration

At the input only one circuit breaker is needed, given the nominal current is rated according to the total input current. At the output, each Mass GI shall be provided with a circuit breaker and the common output must contain a GFCI suitable for the total output current.

Connect both the earth (PE/GND) and the neutral (N) of the AC output of the Mass GI to the grounding point. Otherwise the GFCI will not function properly.

Circuit breakers on the output

Model	1 unit	2 units	3 units	4 units
Mass GI 3.5	16A	32A	50A	63A
Mass GI 7.0	32A	63A	n.a.	n.a.

12. Troubleshooting

Troubleshooting

Problem	Possible cause	What to do?
No output power, all LED indicators are off.	Main switch is in position STAND BY.	Switch ON the Mass GI.
	No shore power available on AC input.	Check the circuit breaker of the shore power. Check the wiring of the shore power cable.
	20AT fuse has tripped.	Reset the fuse, see Chapter 8.
No output power, only the On LED (Figure Exterior, page 4, ref. 5) illuminates.	External GFCI has tripped.	Mass GI is working normally. Check the external GFCI at the AC output (if applied).
No output power, OVP/UVP LED is on.	Input voltage is/ was either too high or too low.	Check the input voltage. Then reset the Mass GI by switching it Standby, On or by using Reset (MasterBus).
No output power, OVP/UVP LED is blinking.	Input frequency is/ was either too high or too low.	Check the input frequency. Then reset the Mass GI, see Chapter 8.
No output power, High temp LED is on.	Ambient temperature is too high.	Check temperature. Reduce load and let the Mass GI cool down. Then reset the Mass GI, see Chapter 8.
	Fan is blocked.	Make sure the fan is not blocked by the wiring of the connection compartment. See Chapter 6 to open the connection compartment.
	Too much load connected.	Reduce the connected load. Then reset the Mass GI, see Chapter 8. Use an extra GI in parallel.

Troubleshooting

Problem	Possible cause	What to do?
No output power, Short circuit LED is on.	Short circuit at the output.	Remove the short circuit. Then reset the Mass GI, see Chapter 8.
No output power, “100%” LED illuminates red.	Overload.	Reduce the connected load. Then reset the Mass GI, see Chapter 8.
MasterView Easy panel connected to the GI, no communication.	The Easy panel has been switched off or MasterBus is not working correctly.	Check MasterBus wiring, a terminator should be placed on both ends of the MasterBus network.
Parallel units are shut off due to overload while load is less than 3.5 (7.0) kW per unit.	Installation fault.	Cable lengths and thickness must be of the same size for all units.
No MasterView display function.	Display is switched off.	Switch on display, refer to display manual.
	Error in the wiring.	Check the MasterBus cables.
	No powering device available on the MasterBus.	With shore power disconnected the Mass GI does not power the MasterBus network. At least one other connected MasterBus device should have powering capabilities, see Chapter 8.
Slow or no MasterBus communication.	Error in the MasterBus wiring.	Check the MasterBus cables.
	No terminating device placed at the ends of the network.	MasterBus needs a terminating device on both ends of the network.
	MasterBus network is configured as a ring network.	Ring networks are not allowed. Check the connections of the network.
Mass GI 7.0 does not operate	No MasterBus terminator present	Plug a MasterBus terminator in one of the MasterBus connectors of the unit

13. Technical data

	Mass GI 3.5	Mass GI 7.0
<i>Product code</i>	88000355	88000705
<i>Nominal power</i>	3500VA @ 230V	7000VA @ 230V
Input		
Input voltage	90-255 V	90-255 V
Input frequency	45 – 65Hz	45 – 65Hz
Nominal input current	16A cont	32A cont
No load AC current consumption	≤ 60W rms	≤ 60W rms
Standby AC current consumption	≤ 600mA rms / 11W	≤ 600mA rms / 11W
DC current consumption, no MasterBus traffic	≤ 10mA	≤ 10mA
Earth leakage protection:	Not present inside, an external GFCI is required	
Output		
Output voltage	Same as input voltage ± 5%	Same as input voltage ± 5%
Output frequency	Same as input frequency	Same as input frequency
Output current behaviour	Fuse B characteristic	Fuse B characteristic
Efficiency (max)	>93%	>93%
MasterBus powering capability	Yes but only if shore power is present	Yes but only if shore power is present
Options		
Remote panel:	Optional, EasyView panel.	Optional, EasyView panel.
Parallel operation:	Yes, up to four units can be paralleled.	Yes, up to two units can be paralleled.
General		
Dimensions L x W x H:	371 x 261 x 145mm / 14.6 x 10.3 x 5.7 inch	371 x 261 x 232mm / 14.6 x 10.3 x 9.1 inch
Approximate weight:	5.6 kg (12 lbs)	10 kg (22 lbs)
Specified operation temperature: (will meet specified tolerances)	Full specifications from 0°C/32°F to 40°C/104°F. Derating: 5%/°C (3%/°F) at ambient temperatures from 40°/104°F to 60°C/140°F. Shutdown at 90°C/194°F heat sink temperature.	
Allowed operating temperature: (may not meet specified tolerances)	-20°C/-4°F to 60°C/140°F	-20°C/-4°F to 60°C/140°F
Non-operating temperature: (storage temperature)	Ambient temperature -40°C/-40°F to 100°C/212°F	Ambient temperature -40°C/-40°F to 100°C/212°F
Relative humidity:	Max 95% relative humidity, non-condensing.	Max 95% relative humidity, non-condensing.
Environment class:	IP 23	IP 23

Rely only on high-grade marine power converters offered on our virtual shelves.