

ENDURA MAX

TRANSOM-MOUNT TROLLING MOTOR

USER MANUAL

CE MASTER USER MANUAL (FOR CE/C-TICK CERTIFIED MODELS)

Conforms to 89/336/EEC (EMC) under standards EN 55022A, EN 50082-2 since 1996 LN V9677264

THANK YOU

Thank you for choosing Minn Kota. We believe that you should spend more time fishing and less time positioning your boat. That's why we build the smartest, toughest, most intuitive trolling motors on the water. Every aspect of a Minn Kota trolling motor is thought out and rethought until it's good enough to bear our name. Countless hours of research and testing provide you the Minn Kota advantage that can truly take you "Anywhere. Anytime." We don't believe in shortcuts. We are Minn Kota. And we are never done helping you catch more fish.

Please thoroughly read this user manual. Follow all instructions and heed all safety and cautionary notices below. Use of this motor is only permitted for persons that have read and understood these user instructions. Minors may use this motor only under adult supervision.

ATTENTION: Never run the motor out of the water, as this may result in injuries from the rotating propeller. The motor should be disconnected from the power source when it is not in use or is off the water. When connecting the power-supply cables of the motor to the battery, ensure that they are not kinked or subject to chafe and route them in such a way that persons cannot trip over them. Before using the motor make sure that the insulation of the power cables is not damaged. Disregarding these safety precautions may result in electric shorts of battery(s) and/or motor. Always disconnect motor from battery(s) before cleaning or checking the propeller. Avoid submerging the complete motor as water may enter the lower unit through control head and shaft. If the motor is used while water is present in the lower unit considerable damage to the motor can occur. This damage will not be covered by warranty.

CAUTION: Take care that neither you nor other persons approach the turning propeller too closely, neither with body parts nor with objects. The motor is powerful and may endanger or injure you or others. While the motor is running watch out for persons swimming and for floating objects. Persons whose ability to run the motor or whose reactions are impaired by alcohol, drugs, medication, or other substances are not permitted to use this motor. This motor is not suitable for use in strong currents. The constant noise pressure level of the motor during use is less than 70dB(A). The overall vibration level does not exceed 2,5m/sec².

FEATURES

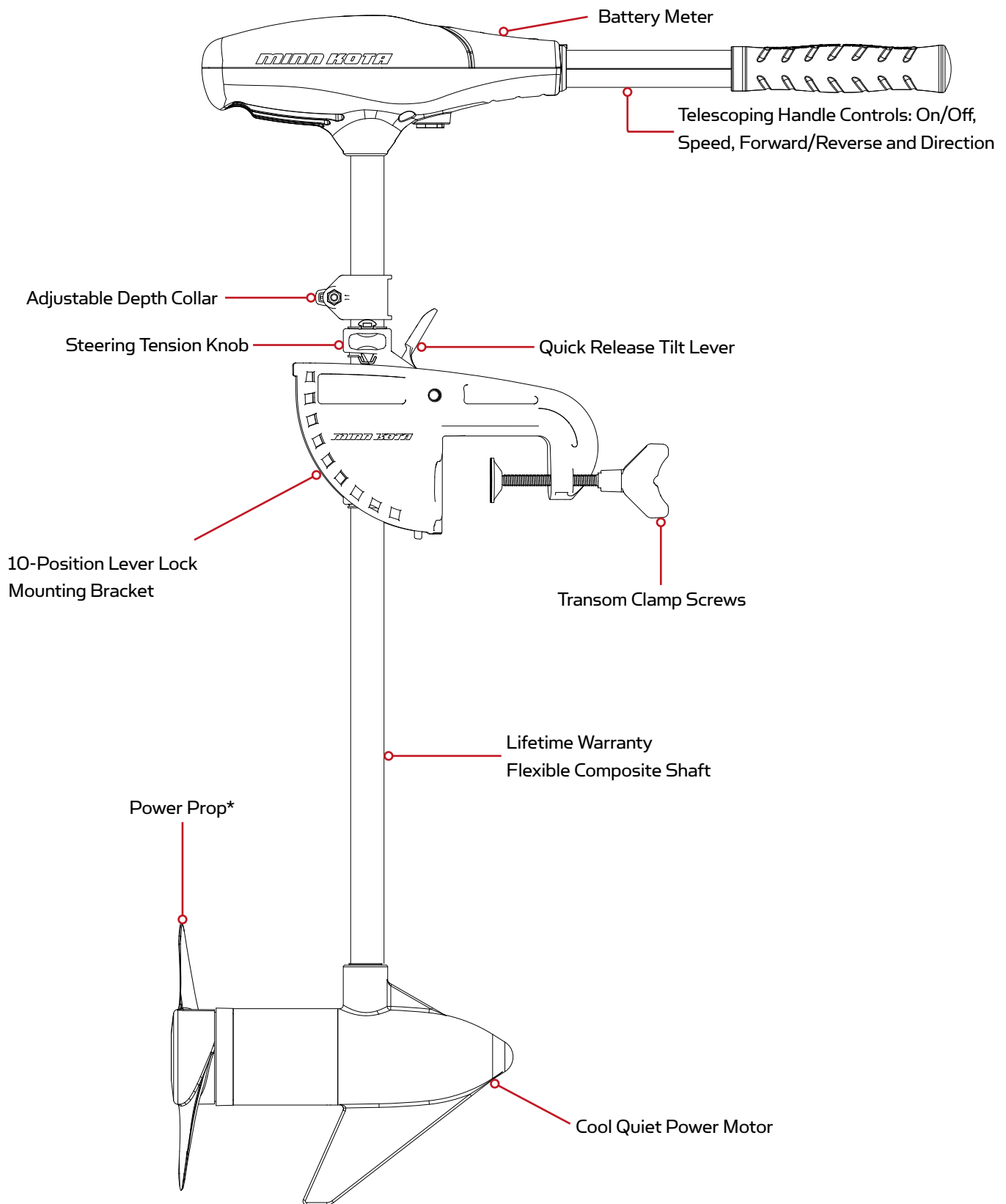

Specifications subject to change without notice.

*This diagram is for reference only and may differ from your actual motor.

INSTALLATION

HANDLE INSTALLATION

1. Remove the wire clip from the ball detent located on the inner handle.
2. Install outer handle over inner handle. Position the handles so the ball detent and OFF are aligned.
3. Push the outer handle into the control box until handle “clicks” into place. The handle is held in place with locking fingers, so some force may be required to lock the handles together.
4. Once the handle is locked into the control box, it can be rotated and extended for normal use.
5. Once the handle is installed, the assembly is permanent. Do not attempt to remove the handle.

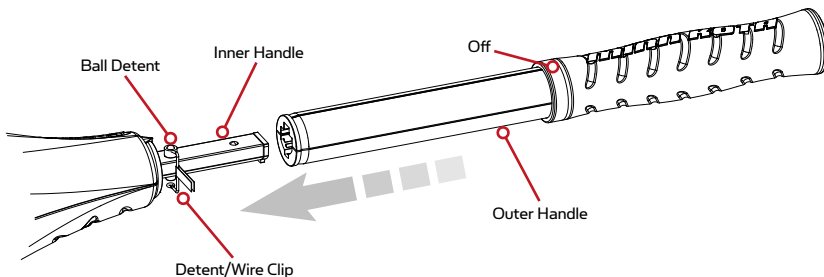

MOTOR INSTALLATION

1. Find a transom area of the boat that is free from obstructions.
2. Open the clamp screws on the bracket enough so that it will fit over the top of the boat transom.
3. Place the Lever Lock Mounting bracket over the top of the boat transom so that the bracket is resting on top of the transom.
4. Verify that there are no obstacles that the control box, handle, or prop might hit while in use that would restrict steering or cause damage to the motor.
5. Tighten down the clamp screws to the transom by hand only. Do not use any tools to tighten the clamp screws as this may damage the bracket or your boat.
6. We recommend the tilt angle of the motor to be adjusted so that the motor shaft is perpendicular to the water surface when the motor is in use.
7. For transport, always tilt the motor into the boat, such that the motor and prop assembly are completely out of the water and the motor is positioned up close to the lever lock bracket.

NOTE: When setting the depth be sure the top of the motor is submerged at least 12" to avoid churning or agitation of surface water. The propeller must be completely submerged.

CAUTION:

- **Never operate your motor when it is out of the water.**
- **Over-tightening the clamp screws can damage the bracket.**

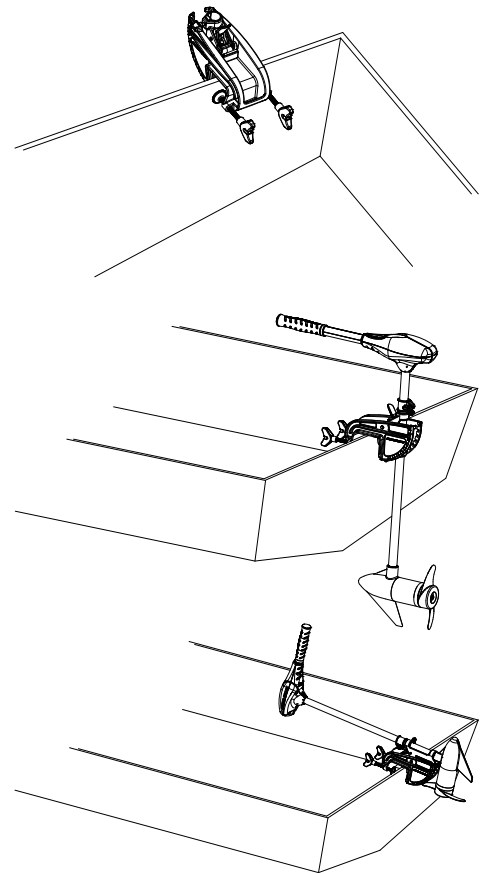

BATTERY WIRING & INSTALLATION

BOAT RIGGING & PRODUCT INSTALLATION

For safety and compliance reasons, we recommend that you follow American Boat and Yacht Council (ABYC) standards when rigging your boat. Altering boat wiring should be completed by a qualified marine technician. The following specifications are for general guidelines only:

CAUTION: These guidelines apply to general rigging to support your Minn Kota motor. Powering multiple motors or additional electrical devices from the same power circuit may impact the recommended conductor gauge and circuit breaker size. If you are using wire longer than that provided with your unit, follow the conductor gauge and circuit breaker sizing table below. If your wire extension length is more than 25 feet, we recommend that you contact a qualified marine technician.

An over-current protection device (circuit breaker or fuse) must be used. Coast Guard requirements dictate that each ungrounded current-carrying conductor must be protected by a manually reset, trip-free circuit breaker or fuse. The type (voltage and current rating) of the fuse or circuit breaker must be sized accordingly to the trolling motor used. The table below gives recommended guidelines for circuit breaker sizing.

Reference:

United States Code of Federal Regulations: 33 CFR 183 – Boats and Associated Equipment
ABYC E-11: AC and DC Electrical Systems on Boats

CONDUCTOR GAUGE AND CIRCUIT BREAKER SIZING TABLE

Motor Thrust / Model	Max Amp Draw	Circuit Breaker	Wire Extension Length *				
			5 feet	10 feet	15 feet	20 feet	25 feet
30 lb.	30	50 Amp @ 12 VDC	10 AWG	10 AWG	8 AWG	6 AWG	4 AWG
40 lb., 45 lb.	42		10 AWG	8 AWG	6 AWG	4 AWG	4 AWG
50 lb., 55 lb.	50	60 Amp @ 12 VDC	8 AWG	6 AWG	4 AWG	4 AWG	2 AWG
70 lb.	42	50 Amp @ 24 VDC	10 AWG	10 AWG	8 AWG	8 AWG	6 AWG
80 lb.	56	60 Amp @ 24 VDC	8 AWG	8 AWG	8 AWG	6 AWG	6 AWG
101 lb.	46	50 Amp @ 36 VDC	8 AWG	8 AWG	8 AWG	8 AWG	8 AWG
Engine Mount 101	50	60 Amp @ 36 VDC	8 AWG	6 AWG	4 AWG	4 AWG	2 AWG
112 lb.	52	60 Amp @ 36 VDC	8 AWG	8 AWG	8 AWG	8 AWG	8 AWG
Engine Mount 160	116	(2) x 60 Amp @ 24 VDC	2 AWG	2 AWG	2 AWG	2 AWG	2 AWG
E-Drive	40	50 Amp @ 48 VDC	10 AWG	10 AWG	10 AWG	10 AWG	10 AWG

This conductor and circuit breaker sizing table is only valid for the following assumptions:

1. No more than 3 conductors are bundled together inside of a sheath or conduit outside of engine spaces.
2. Each conductor has 105° C temp rated insulation.
3. No more than 5% voltage drop allowed at full motor power based on published product power requirements.

***Wire Extension Length refers to the distance from the batteries to the trolling motor leads.**

BATTERY WIRING & INSTALLATION

SELECTING THE CORRECT BATTERIES

The motor will operate with any lead acid, deep cycle marine 12 volt battery/batteries. For best results, use a deep cycle, marine battery with at least a 105 ampere hour rating. Maintain battery at full charge. Proper care will ensure having battery power when you need it, and will significantly improve the battery life. Failure to recharge lead-acid batteries (within 12-24 hours) is the leading cause of premature battery failure. Use a multi-stage charger to avoid overcharging. We offer a wide selection of chargers to fit your charging needs. If you are using a crank battery to start a gasoline outboard, we recommend that you use a separate deep cycle marine battery/batteries for your Minn Kota trolling motor.

Advice Regarding Batteries:

- Never connect the (+) and the (-) terminals of the battery together. Take care that no metal object can fall onto the battery and short the terminals. This would immediately lead to a short and extreme fire danger.
- It is highly recommended that a circuit breaker or fuse be used with this trolling motor. Refer to “Conductor Gauge and Circuit Breaker Sizing Table” in the previous section to find the appropriate circuit breaker or fuse for your motor. For motors requiring a 60-amp breaker, the Minn Kota MKR-19 60-amp circuit breaker is recommended.

HOW TO CONNECT THE BATTERIES

12 VOLT SYSTEMS:

1. Make sure that the motor is switched off (speed selector on “OFF” or “0”).
2. Connect positive (+) red lead to positive (+) battery terminal.
3. Connect negative (-) black lead to negative (-) battery terminal.
4. For safety reasons do not switch the motor on until the propeller is in the water.

CAUTION:

For safety reasons, disconnect the motor from the battery/batteries when the motor is not in use or while the battery/batteries are being charged.

PUSH-TO-TEST BATTERY METER

This motor is equipped with a “push to test” battery meter. The LED provides an accurate display of the remaining charge in the battery. It is only accurate when the motor is off.

The meter reads as:

- One light indicates recharge.
- Two lights indicate low charge.
- Three lights indicate good charge.
- Four lights indicate full charge.

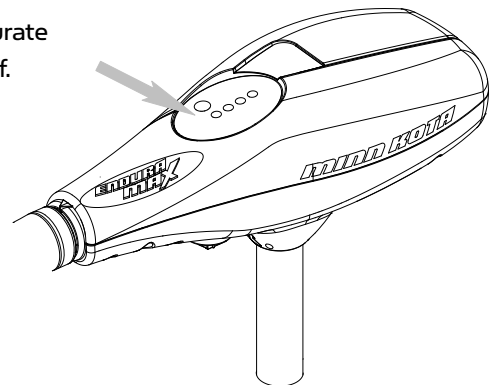

MOTOR WIRING DIAGRAM

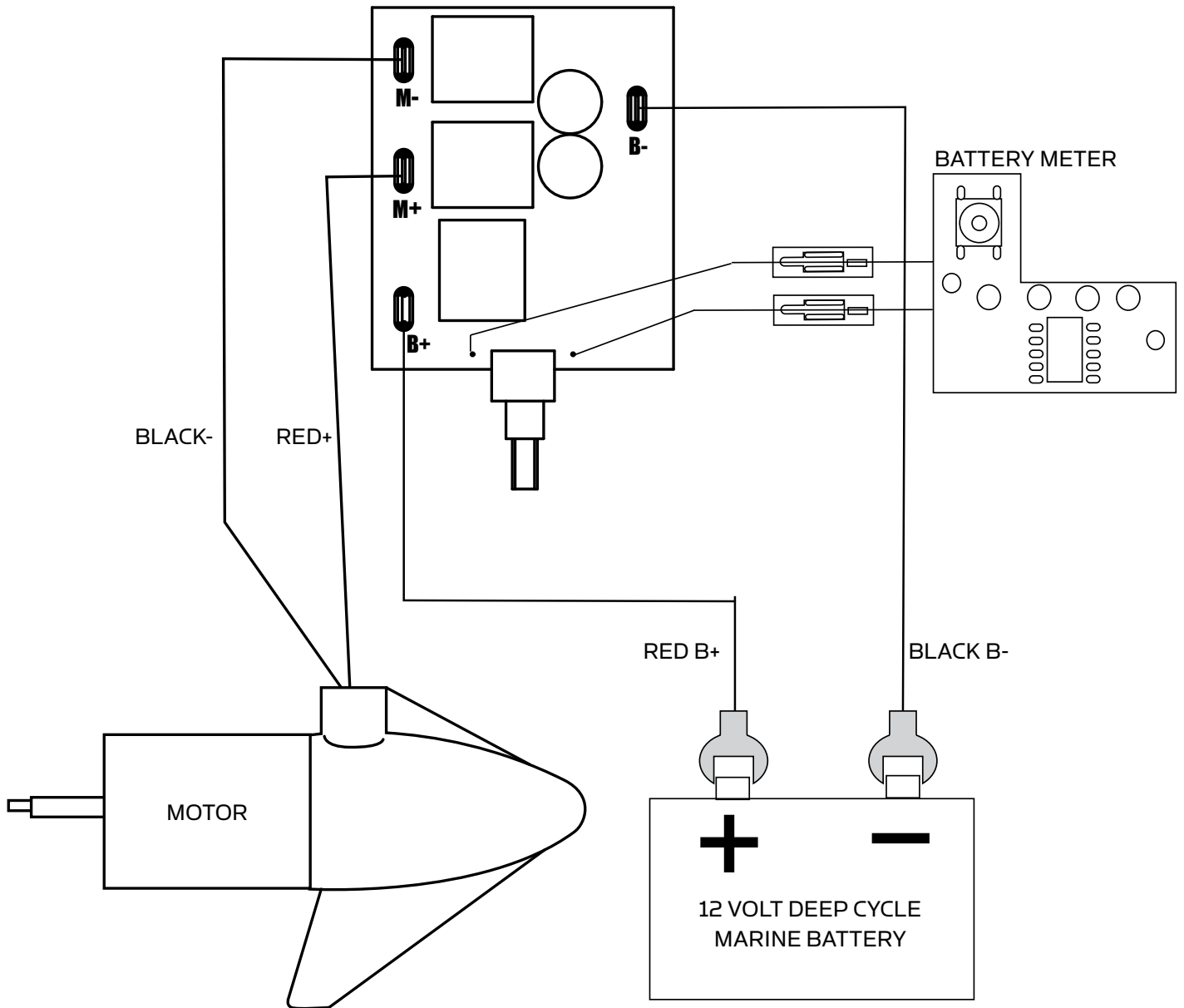

USING & ADJUSTING THE MOTOR

TO ADJUST THE DEPTH OF THE MOTOR

When setting the depth be sure the top of the motor is submerged at least 12" to avoid churning or agitation of surface water. The propeller must be completely submerged.

1. Firmly grasp the composite shaft and hold it steady.
2. Loosen the steering tension knob and depth collar knob until the shaft slides freely.
3. Raise or lower the motor to the desired depth.
4. Tighten depth collar knob to secure the motor in place.

CAUTION:

- **Never operate your motor when it is out of the water.**
- **Over-tightening the clamp screws can damage the bracket.**

STEERING ADJUSTMENT

- Adjust the steering tension knob to provide enough tension to allow the motor to turn freely, yet remain in any position without being held

OR

- Tighten the knob to place the motor in a preset position to leave your hands free for fishing.

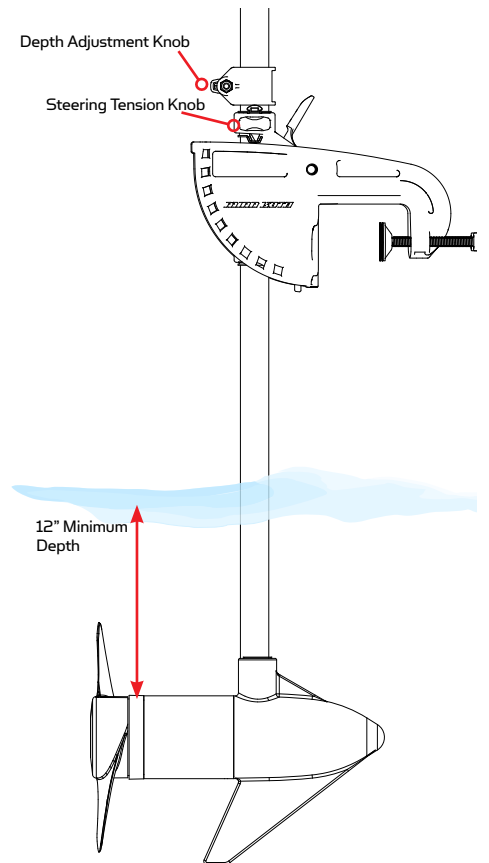

CONTROLLING SPEED AND DIRECTION:

These motors are equipped with an extension twist tiller with a telescoping handle, which offers variable forward and reverse speeds. The speed control may be operated in either direction, forward or reverse. Turn the tiller handle counterclockwise from (OFF) to increase reverse speed and clockwise from (OFF) to increase forward speed. Thrust decreases as you approach (OFF) from either direction.

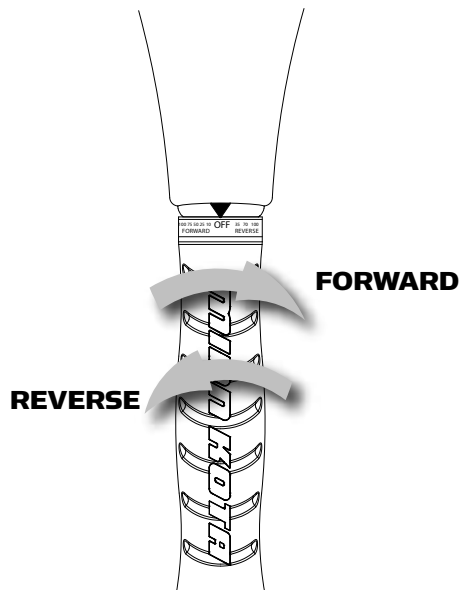

BRACKET ADJUSTMENT

You can lock your motor in a vertical position, angle it for shallow water or tilt it completely out of the water.

1. Firmly grasp the control head or composite shaft.
2. Press the tilt lever toward the shaft and hold to release the detent lock or T-bar to adjust the position of the mounting bracket.
3. Tilt to any of the positions on the mounting bracket.
4. Release the tilt lever.

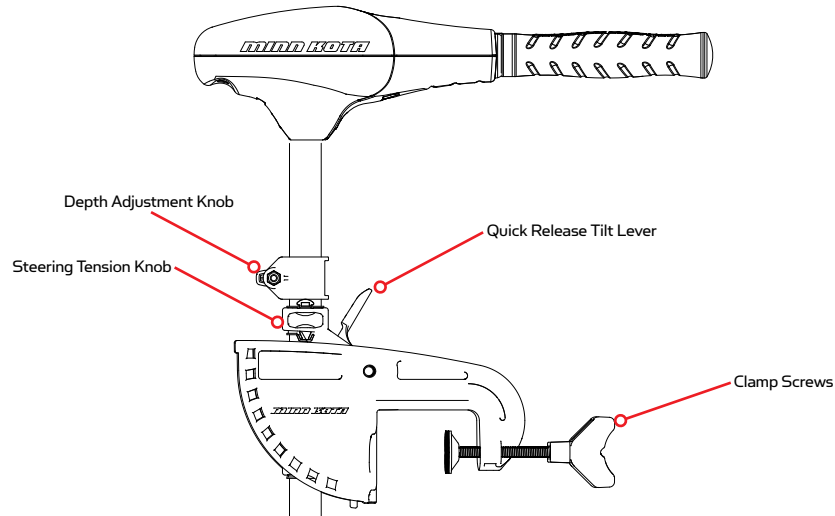

STOWING THE MOTOR

1. Adjust depth so that the motor is fully raised.
2. Press and hold tilt lever.
3. Tilt motor into the boat.
4. For transport, always tilt the motor into the boat such that the motor and prop assembly are completely out of the water and the motor is positioned up close to the lever lock bracket.

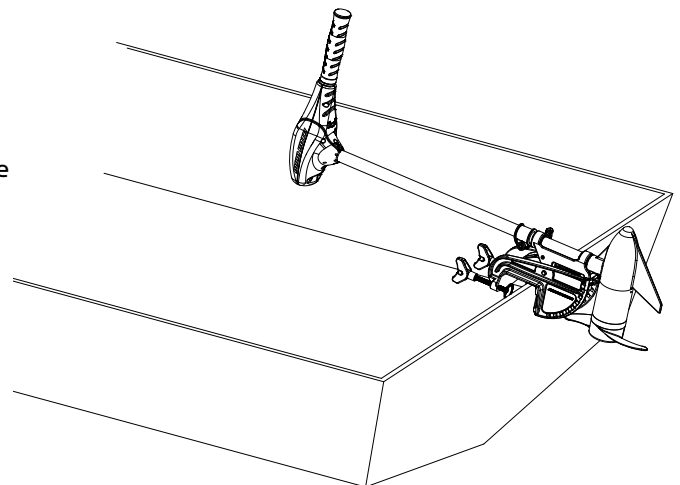

WARNING: When raising/lowering motor or operating the tilt mechanism, keep fingers clear of all hinge and pivot points and all moving parts.

SERVICE & MAINTENANCE

PROPELLER REPLACEMENT

TOOLS AND RESOURCES REQUIRED:

- 7/16" Box End Wrench
- Screwdriver (optional)

CAUTION:

Disconnect the motor from the battery before beginning any prop work or maintenance.

NOTE: The propeller on your motor may differ from the one pictured.

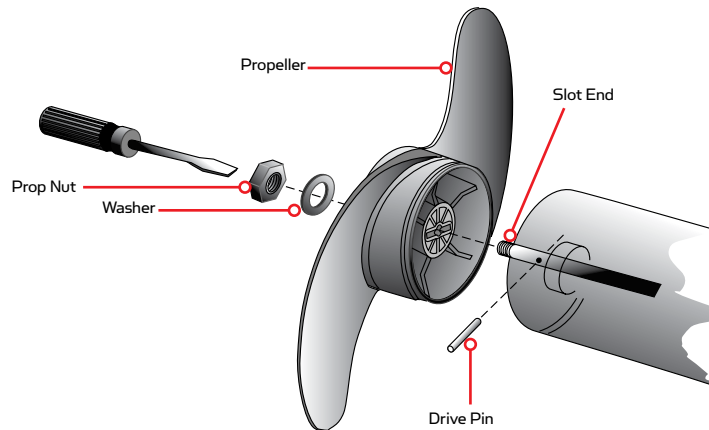

1. Disconnect the motor from all sources of power prior to changing the propeller.
2. Hold the propeller and loosen the prop nut with pliers or a wrench.
3. Remove the prop nut and washer. If the drive pin is sheared or broken, you will need to hold the shaft stationary with a blade screwdriver pressed into the slot on the end of the shaft.
4. Turn the old prop to horizontal (as illustrated) and pull it straight off. If drive pin falls out, push it back in.
5. Align the new propeller with the drive pin.
6. Install the prop washer and prop nut.
7. Tighten the prop nut 1/4 turn past snug [25-35 inch lbs.] Do not over tighten as this can damage the prop.

GENERAL MAINTENANCE

1. After use, the entire motor should be rinsed with freshwater, then wiped down with a cloth dampened with an aqueous based silicone spray. This series of motors is not equipped for saltwater exposure.
2. The propeller must be inspected and cleaned from weeds and fishing line after every use. Fishing line and weeds can get behind the prop, damage the seals and allow water to enter the motor.
3. Verify the prop nut is secure each time the motor is used.
4. To prevent accidental damage during transportation or storage, disconnect the battery whenever the motor is off of the water. For prolonged storage, lightly coat all metal parts with an aqueous based silicone spray.
5. For maximum battery life recharge the battery(s) as soon as possible after use. For maximum motor performance restore battery to full charge prior to use.
6. Keep battery terminals clean with fine sandpaper or emery cloth.
7. The propeller is designed to provide weed free operation with very high efficiency. To maintain this top performance, the leading edge of the blades must be kept smooth. If they are rough or nicked from use, restore to smooth by sanding with fine sandpaper.

TROUBLESHOOTING & REPAIR

1. Motor fails to run or lacks power:
 - Check battery connections for proper polarity.
 - Make sure terminals are clean and corrosion free. Use fine sandpaper or emery cloth to clean terminals.
 - Check battery water level. Add water if needed.
2. Motor loses power after a short running time:
 - Check battery charge. If low, restore to full charge.
3. Motor is difficult to steer:
 - Loosen the steering tension knob on the bracket
 - Lubricate the composite shaft.
4. You experience prop vibration during normal operation:
 - Remove and rotate the prop 180°. See removal instructions in the Propeller Replacement section.
5. Experiencing interference with your fishfinder:
 - You may, in some applications, experience interference in your depth finder display. We recommend that you use a separate deep cycle marine battery for your trolling motor and that you power the depth finder from the starting/cranking battery.

PARTS DIAGRAM

ENDURA MAX 40

40 LBS THRUST - 12 VOLT - 36" SHAFT

This page provides Minn Kota® WEEE compliance disassembly instructions. For more information about where you should dispose of your waste equipment for recycling and recovery and/or your European Union member state requirements, please contact your dealer or distributor from which your product was purchased.

Tools required, but not limited to: flat head screw driver, Phillips screw driver, socket set, pliers, wire cutters.

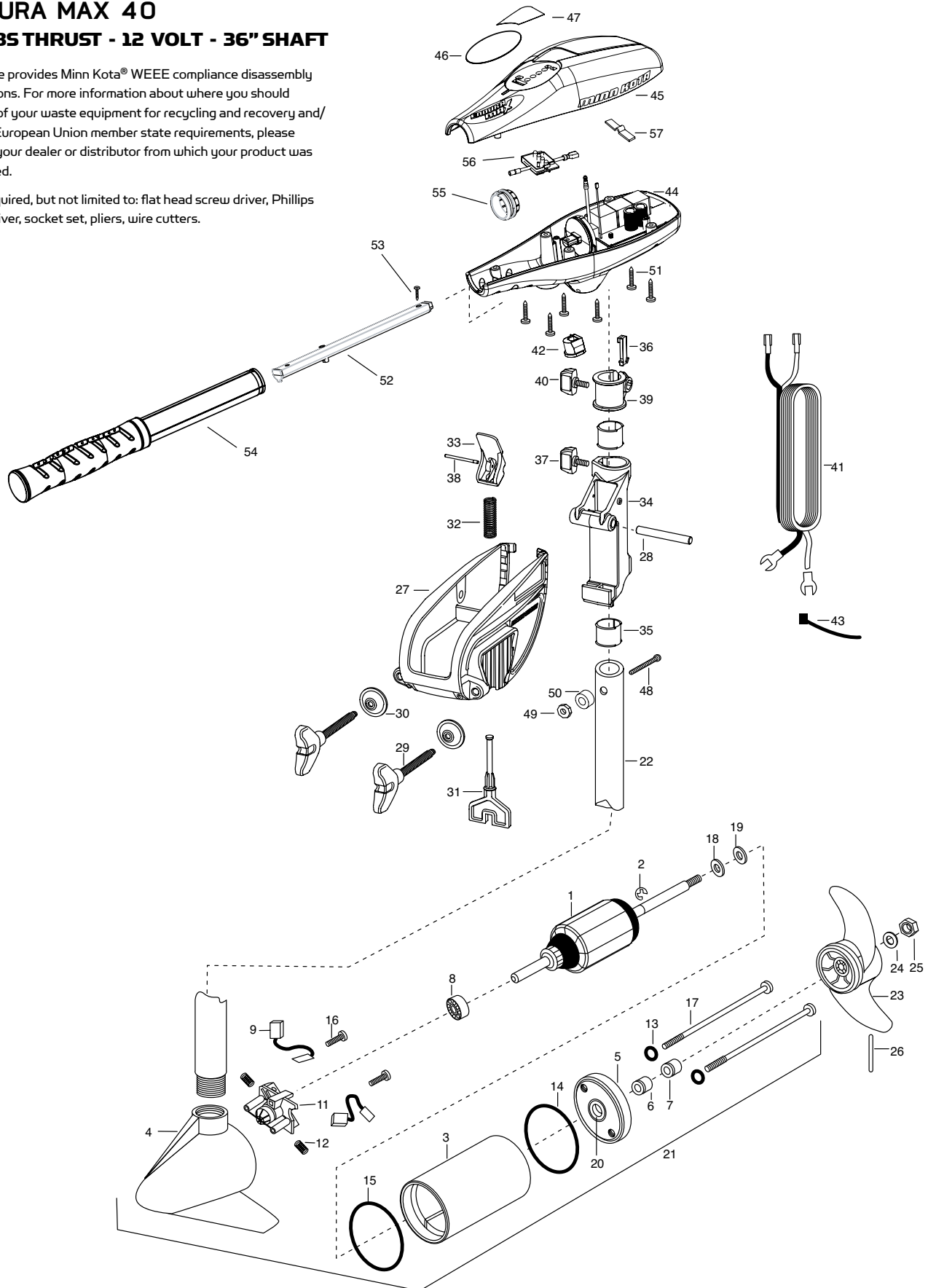

PARTS LIST

ENDURA MAX 40

40 LBS THRUST - 12 VOLT - 36" SHAFT

ITEM	QTY	PART NUMBER	DESCRIPTION
1	1	2-100-204	ARMATURE ASSEMBLY 12V 3.25
2	1	788-015	RETAINING RING
3	1	2-200-079	HOUSING ASSEMBLY CENTER 3.25 TXT
4	1	421-132	BRUSH END HOUSING ASSEMBLY 3.25
5	1	2-400-128	PLAIN END HOUSING ASSEMBLY 3.25
6	1	880-003	SEAL
7	1	880-006	SEAL W/SHIELD
8	1	140-010	BALL BEARING
9	2	188-052	BRUSH ASSEMBLY
11	1	2-600-285	BRUSH PLATE W/HOLDER 3.25
12	2	975-032	COMPRESSION SPRING
13	2	701-007	O-RING – THRU BOLT
14	1	701-039	O-RING
15	1	701-041	O-RING
16	2	830-001	SCREW – SELF THREAD #8-32X1.7
17	2	830-078	THRU BOLT #8-32X8.0
18	1	990-067	WASHER – STEEL THRUST
19	1	990-070	WASHER – NYLATRON
20	1	144-049	FLANGE BEARING (SERVICE ONLY)
21	1	2069239	MOTOR ASSEMBLY 12 V 3.25 VARIABLE SPD
22	1	2032046	36" COMPOSITE TUBE
■	1	1378121	PROPELLER KIT (INCLUDES 23-26)
23	1	2061122	PROPELLER 3.25 HUB DIA
24	1	2151726	WASHER – 5/16 STD SS
25	1	2053101	NUT – PROP NYLOCK (MED) SS
26	1	2092600	DRIVE PIN
■	1	2771818	BRACKET & HINGE ASSEMBLY (INCLUDES 27-38)
■	1	2771910	BRACKET ASSEMBLY (INCLUDES 27, 29, 30)
*27	1	2061910	BRACKET
28	1	2060510	HINGE PIN

ITEM	QTY	PART NUMBER	DESCRIPTION
*29	2	2061300	SCREW – CLAMP
*30	2	2011710	WASHER – CLAMP SCREW
31	1	2063605	PLASTIC T-BAR
32	1	2062706	T-BAR SPRING
33	1	2067201	BLACK TILT LEVER
34	1	2061810	PLASTIC HINGE
35	2	2037301	BUSHING HINGE
36	1	2062800	SNAP-IN TENSION BLOCK
37	1	2011385	SCREW – TENSION/KNOB
38	1	2060515	TILT LEVER PIN
39	1	2061520	DEPTH COLLAR
40	1	2011365	SCREW – COLLAR/NEW KNOB
41	1	2050609	LEADWIRE (WITH 10GA HD SPADE TERMINAL)
42	1	2062905	STRAIN RELIEF
43	1	2256300	TIE WRAP
44	1	2994040	CONTROL BOX
45	1	2060225	CONTROL BOX COVER
46	1	2065715	DECAL COVER ENDURA MAX 40
47	1	2065730	COVER DECAL
48	1	2033401	SCREW – #10-24 X 1-3/4
49	1	2383124	NUT – 10-24 HEX
50	1	2061720	NYLON WASHER
51	6	2012100	SCREW – #8-18 X 5/8
52	1	2990924	INNER HANDLE ASSEMBLY
53	1	2012104	SCREW – #6 X 1/2" SS
54	1	2990913	OUTER HANDLE ASSEMBLY
55	1	2060009	FRONT BEARING
56	1	2074070	BATTERY METER 12V
57	1	2302742	DETENT SPRING - OFF
■	1	2883460	SEAL AND O-RING KIT (INCLUDES 6-7, 13-15)

■ THIS ITEM IS PART OF AN ASSEMBLY.

*THIS ITEM IS PART OF A KIT AND ONLY LISTED FOR VIEWING PURPOSES.

RECOMMENDED ACCESSORIES

ON-BOARD & PORTABLE BATTERY CHARGERS

Stop buying new batteries and start taking care of the ones you've got. Many chargers can actually damage your battery over time – creating shorter run times and shorter overall life. Digitally controlled Minn Kota chargers are designed to provide the fastest charge that protect and extend battery life.



MK345PC



MK212D



MK105P

TALON SHALLOW WATER ANCHOR

Talon deploys faster, holds stronger and runs quieter than any other shallow water anchor. Available in depths up to 12' and bold color options, it boasts an arsenal of features and innovations that no other anchor can touch:



- Vertical, multi-stage deployment
- User-Selectable Anchoring Modes
- 2x Anchoring Force
- Fast Deploy
- Auto Up/Down
- Triple Debris shields*
- Built-In Wave Absorption
- Noise Dissipation
- Versatile Adjustments

*available on 10' and 12' models only

MINN KOTA ACCESSORIES

We offer a wide variety of trolling motor accessories, including:



- 60-Amp Circuit Breaker
- Mounting Brackets
- Stabilizer Kits
- Extension Handles
- Battery Connectors
- Battery Boxes
- Quick Connect Plugs

Learn more about boat motors we have.