



## Master User Manual for **RIPTIDE SF**



### **BOW MOUNT HAND CONTROL SALTWATER MOTORS**

PLEASE THOROUGHLY READ THIS USER MANUAL. FOLLOW ALL INSTRUCTIONS AND HEED ALL SAFETY & CAUTIONARY NOTICES BELOW. USE OF THIS MOTOR IS ONLY PERMITTED FOR PERSONS THAT HAVE READ AND UNDERSTOOD THESE USER INSTRUCTIONS. MINORS MAY USE THIS MOTOR ONLY UNDER ADULT SUPERVISION.

**RIPTIDE OVERVIEW**

**Advanced Saltwater Corrosion Protection:**

- 3-mil acrylic paint
- E-coated epoxy
- Chromate conversion coat
- 7-step cleaning process
- Premium marine alloy



Specifications subject to change without notice.

## ASSEMBLY OF MOTOR TO MOUNT:

1. Place the mount on an elevated surface such as a workbench or tailgate of pickup.
2. Remove the 5/16" Allen screw and lock washer from the mount using an Allen wrench. (See picture)
3. Align the key ways on the inside of the bowguard with the ends links on the mount. Lower the motor assembly straight down until seated.
4. Install the 5/16" Allen screw / lock washer and tighten to 10-12 ft/lbs.
5. Stow the motor into the flat position by pulling the rope/handle to disengage the latch bar, allowing the motor to fold into the flat position.
6. Once in the stowed or flat position, the gas spring pin can be installed. Follow the steps below to install the gas spring pin:
  - Locate the upper gas spring pin in bag assembly
  - Align the end of the gas spring with the holes in the

outer arm

- Install pin and Phillips flat head screws
- Tighten screws until the heads are flush with the outer arm

**NOTE:** Screws have a pre-applied thread locker, DO NOT apply additional thread locker to screws as that may prevent future removal.

7. Motor / mount can now be installed onto the boat. Proceed to next page for mounting instructions.

**ATTENTION:** The 5/16" Allen screw must be tight when installed and periodically tightened to 10-12 ft/lbs (Step 4), which will allow the motor to be stowed properly. Tighten the Allen screw when the mount is in the deployed position.

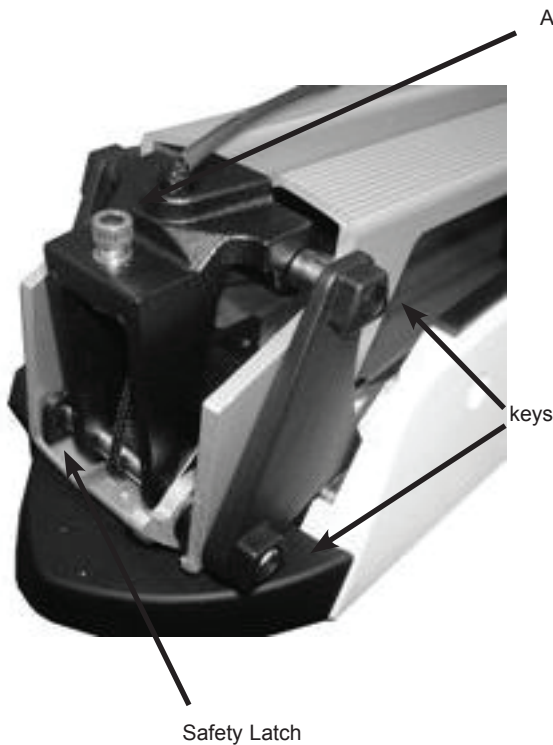

## INSTALLATION OF THE BOWMOUNT:

We recommend that you have another person help with this procedure.

1. For installation, do not remove the shaft/motor from the Bowguard. The Bowguard spring is under tension and must always remain secured.
2. Place the mount, with the motor in the fully retracted (flat) position, on the deck of the boat:
  - The motor should be mounted as close to the centerline of the boat as possible.
  - Make sure bow area under the chosen location is clear and unobstructed for drilling.

- Make sure the motor rest is positioned far enough beyond the edge of the boat. The motor, as it is lowered into the water or raised into the boat, must not encounter any obstructions.

3. Once in position, mark at least four (4) of the holes provided in the bow plate and drill through the marks using a (9/32") bit.
4. Mount the plate to the bow through the drilled holes using the provided (1/4-20 x 3-1/2") bolts, nuts and washers.

**NOTE:** If possible, secure all sets of mounting bolts, nuts and washers.

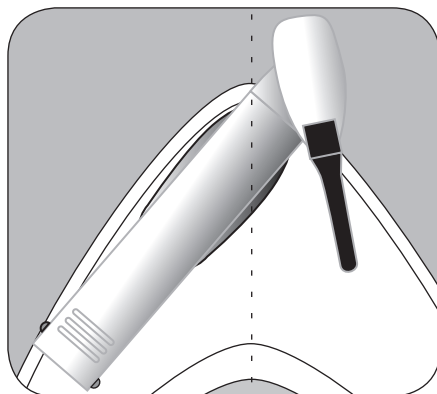

Minn Kota are proud to offer a high quality product at the industries most competitive pricing!

## INSTALLING THE BOWMOUNT STABILIZER: (if Included)

1. Place motor in the stowed position
2. Unthread the composite rod from the bracket and attach bracket to the bottom of the bowguard using the 5/16" cap screws and nuts. The nuts fit into pocket on the inside of the bowguard behind the spring.

**NOTE:** The bracket can be installed on the left or right side of the bowguard.

3. Pull the bumper off the stabilizer rod and place the rod next to the bracket as shown in photo.
4. Place the threaded end down onto the deck surface and mark the rod fl" above the top of the bracket (see photo)
5. Cut the rod to the mark and round the cut edge with a file or sandpaper.
6. Install the bottom bumper to the stabilizer rod and thread the rod into the bracket.
7. Adjust the stabilizer rod up or down to so that the tip **just** touches the support surface. See photo below.  
**WARNING:** Adjusting the rod too tightly removes the end play needed for proper pin engagement and doing so could prevent the mount from fully latching in the stowed position. If installed correctly, the rod tip should lift off the deck about 1/4" without the mount unlatching.
8. Once adjusted, tighten the jam nut against the bracket, which will prevent the rod from turning.
9. Install top cap if threads are exposed.

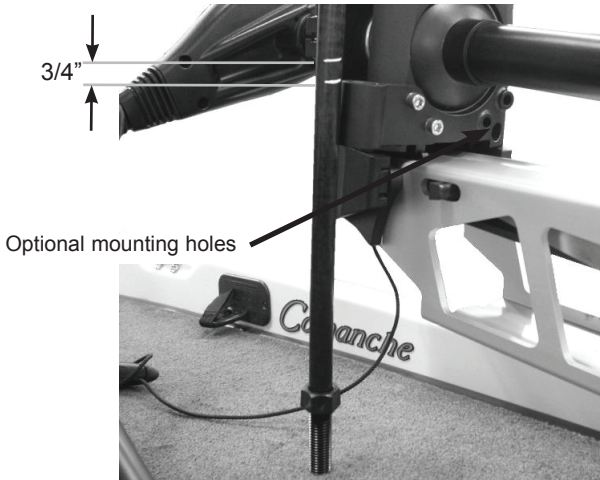

**BOW MOUNT OPERATION:**

- The bow mount is designed to fold back and lock the motor flat on deck when not in use.
- The motor rest positions the lower unit as it comes in contact with the nose of the mount and guides it onto the motor rest.
- The tube lock tilts up and engages the shaft to lock it for transport.
- The hold down strap assembly crosses over the shaft

- and the rectangular ring / Velcro® secures the motor.
- Pull the rope to release the lock bar, which automatically engages when the unit is lowered or raised into position. The pull grip and rope should be used to both lower and raise the unit.
- If the rope disengages from the lock bar assembly, release the lock bar with a screwdriver.

**WARNING : WHEN RAISING OR LOWERING MOTOR, KEEP FINGERS CLEAR OF ALL HINGE AND PIVOT POINTS AND ALL MOVING PARTS.**

**TILT AND EXTENSION HANDLE OPERATION:**

Your Riptide SF trolling motor features 7 usable handle tilt positions...45°, 30°, and 15° up and down from the 0° (horizontal) position. To use the down positions, you must first press the release button located on the left underside of the pivot handle.

Your Riptide SF trolling motor handle also features a unique stow position, that is useful for limiting the

amount of space required for storage or travel. First press the release button located on the left underside of the pivot handle, then push the handle down until you feel the handle "lock in" to the stowed position. This will be almost parallel to the motor shaft.

To extend the handle, pull the handle towards you to the desired position. The handle will extend a full 6 inches. To retract, push the handle in until it meets the face of the motor control head.

**IMPORTANT: THE MOTOR MUST BE IN THE OFF POSITION TO USE THE STOW POSITION! FAILURE TO PUT THE MOTOR IN THE OFF POSITION BEFORE STOWING THE HANDLE WILL RESULT IN JOINT FAILURE.**

Handle controls on/off, steering, forward/reverse



**CAUTION: NEVER OPERATE YOUR MOTOR WHEN IT IS OUT OF THE WATER.**

## OPERATION OF THE PRODUCT CONT'D:

### Depth Adjustment

- The Quick Release Depth Collar can easily be adjusted by opening the lever arm to release the depth collar, sliding it to the desired depth, and then closing the lever arm again. The tension of the quick release depth collar can be adjusted with a screw driver to obtain the proper "feel".

**Be careful not to over tighten!**

**NOTE:** When setting the depth be sure the top of the motor is submerged at least 12" to avoid churning or agitation of surface water. The propeller must be completely submerged.

### STEERING ADJUSTMENT:

- Adjust steering tension knob to provide enough tension to allow the motor to turn freely, yet remain in any position without being held or; Tighten the knob and lock the motor in a preset position to leave your hands free for fishing.

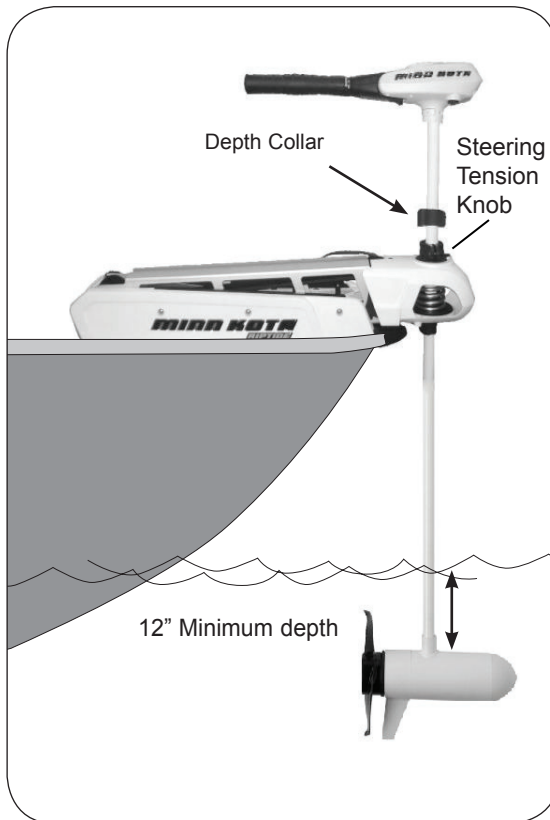

**GAS ASSIST LIFT MECHANISM:**

**WARNING:** The gas assist lift mechanism in this unit is under HIGH SPRING PRESSURE when the motor is in the deployed position. DO NOT remove the BowGuard assembly from the mount without disconnecting one end of the gas spring. Failure to do this can create a condition where accidental pulling of the rope may cause the mount to spring open rapidly, striking anyone or anything in the direct path.

To disconnect one end of the gas spring, follow the instructions below:

1. With the mount in the stowed position, locate the upper cylinder pin.
2. Using two Philips screwdrivers, remove 1 of the Phillips flat head screws.
3. Remove pin from outer arm by sliding thru the arm.
4. Now it is safe to deploy the motor and remove the motor assembly.
5. To re-connect the gas spring, see page 3, step 6.

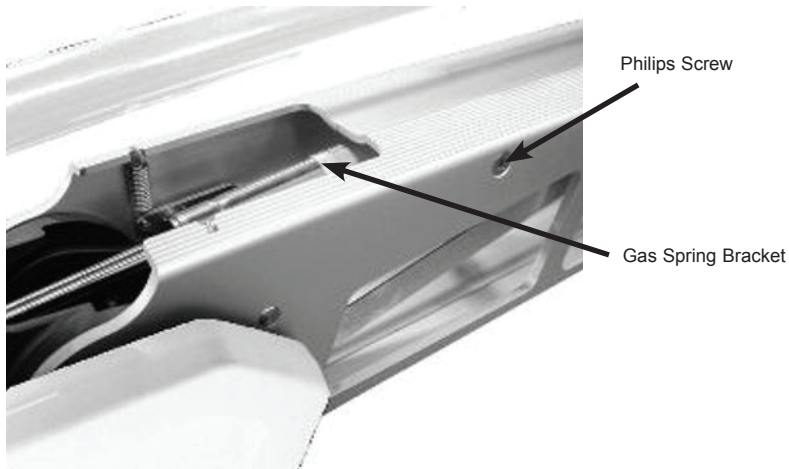



**Attention:**

- Avoid running your motor with the propeller out of the water. This may result in injuries from the rotating propeller.
- It is recommended to set the speed selector to zero and place the motor in the deployed position prior to connecting power cables.
- Always ensure that the power cables are not twisted or kinked; and that they are securely routed to avoid a safety or trip hazard. Ensure cables are unobstructed in all locations to avoid damaging the wire insulation. Damage to the insulation could result in failure or injury.
- Always inspect the insulation of the power cables prior to use to ensure they are not damaged.
- Disregarding these safety precautions may result in an electrical short of the battery(s) and/or motor. Always disconnect the motor from the battery(s) before cleaning or checking the propeller.
- Avoid submerging the complete motor as water may enter the lower unit through control head and shaft. Water in the lower unit may cause an electrical short and damage the lower unit. This damage will not be covered by warranty.

**Caution!**

- Always operate the motor in a safe distance away from obstructions. Never approach the motor when the propeller is running. Contact with a spinning propeller may endanger you or others.
- Always exercise safe practices when using your motor; stay clear of other watercrafts, swimmers, and any floating objects. Always obey water regulations applicable to your area of operation.
- Never operate the motor while under the influence of alcohol, drugs, medication, or other substances which may impair your ability to safely operate equipment.
- This motor is not suitable for use in strong currents exceeding the thrust level of the motor.

The constant noise pressure level of the motor during use is less than 70dB(A). The overall vibration level does not exceed 2,5m/sec<sup>2</sup>.

## BATTERY INFORMATION:

The motor will operate with any deep cycle marine 12 volt battery/batteries. For best results use a deep cycle, marine battery with at least a 115 ampere hour rating. As a general on the water estimate, your 12 volt motor will draw one ampere per hour and your 24 volt motor will draw .75 ampere per hour for each pound of thrust produced when the motor is running on high. The actual ampere draw is subject to your particular environmental conditions and operation requirements. Maintain battery at full charge. Proper care will ensure having battery power when you need it, and will significantly improve the battery life. Failure to recharge lead-acid batteries (within 12-24 hours) is the leading cause of premature battery failure. Use a variable rate charger to avoid overcharging.

If you are using a crank battery to start a gasoline outboard, we recommend that you use a separate deep cycle marine battery/batteries for your Minn Kota trolling motor.

Advice regarding batteries:

**Never connect the (+) and the (-) terminals of the battery together. Take care that no metal object can fall onto the battery and short the terminals. This would immediately lead to a short and utmost fire danger.**

Recommendation: Use battery boxes and covered bat-

tery terminal clamps like Minn Kota accessory #MK-BC-1.

These motors are equipped with a "push to test" battery gauge. The LED provides an accurate display of the remaining charge in the battery. It is only accurate when the motor is off. The gauge reads as:

- Four lights indicate full charge.
- Three lights indicate good charge.
- Two lights indicate low charge.



## BATTERY CONNECTION

### 12 Volt Systems:

1. Make sure that the motor is switched off (speed selector on "0").
2. Connect positive (+) red lead to positive (+) battery terminal.
3. Connect negative (-) black lead to negative (-) battery terminal.
4. For safety reasons do not switch the motor on until the propeller is in the water.

### 24 Volt Systems:

1. Make sure that the motor is switched off (speed selector on "0").
2. Two 12 volt batteries are required.
3. The batteries must be wired in series, only as directed in wiring diagram, to provide 24 volts.
  - a. Connect a connector cable to positive (+) terminal of battery 1 and to negative (-) terminal of battery 2.
  - b. Connect positive (+) red lead to positive (+) terminal on battery 2.
  - c. Connect negative (-) black lead to negative (-) terminal of battery 1.
4. For safety reasons do not switch the motor on until the propeller is in the water.

### 36 Volt Systems:

1. Make sure that the motor is switched off (speed selector on "0").
2. Three 12 volt batteries are required.
3. The batteries must be wired in series, only as directed in wiring diagram, to provide 36 volts.

- a. Connect a connector cable to positive (+) terminal of battery 1 and to negative (-) terminal of battery 2.
- b. Connect a connector cable to positive (+) terminal of battery 2 and to negative (-) terminal of battery 3.
- c. Connect positive (+) red lead to positive (+) terminal on battery 3.
- d. Connect negative (-) black lead to negative (-) terminal of battery 1.
4. For safety reasons do not switch the motor on until the propeller is in the water.

If installing a leadwire plug, observe proper polarity and follow instructions in your boat owner's manual.

See wiring diagram on following pages.

- IMPROPER WIRING OF 24 OR 36 VOLT SYSTEM COULD CAUSE BATTERY EXPLOSION!
- KEEP LEADWIRE WING NUT CONNECTION TIGHT AND SOLID TO BATTERY TERMINALS.
- LOCATE BATTERY IN A VENTILATED COMPARTMENT.

# 12-24-36 VOLT VARIABLE SPEED MODELS

**THIS IS A UNIVERSAL MULTI-VOLTAGE DIAGRAM. DOUBLE CHECK YOUR MOTORS VOLTAGE FOR PROPER CONNECTIONS**

Over-Current Protection Devices not shown in illustrations.

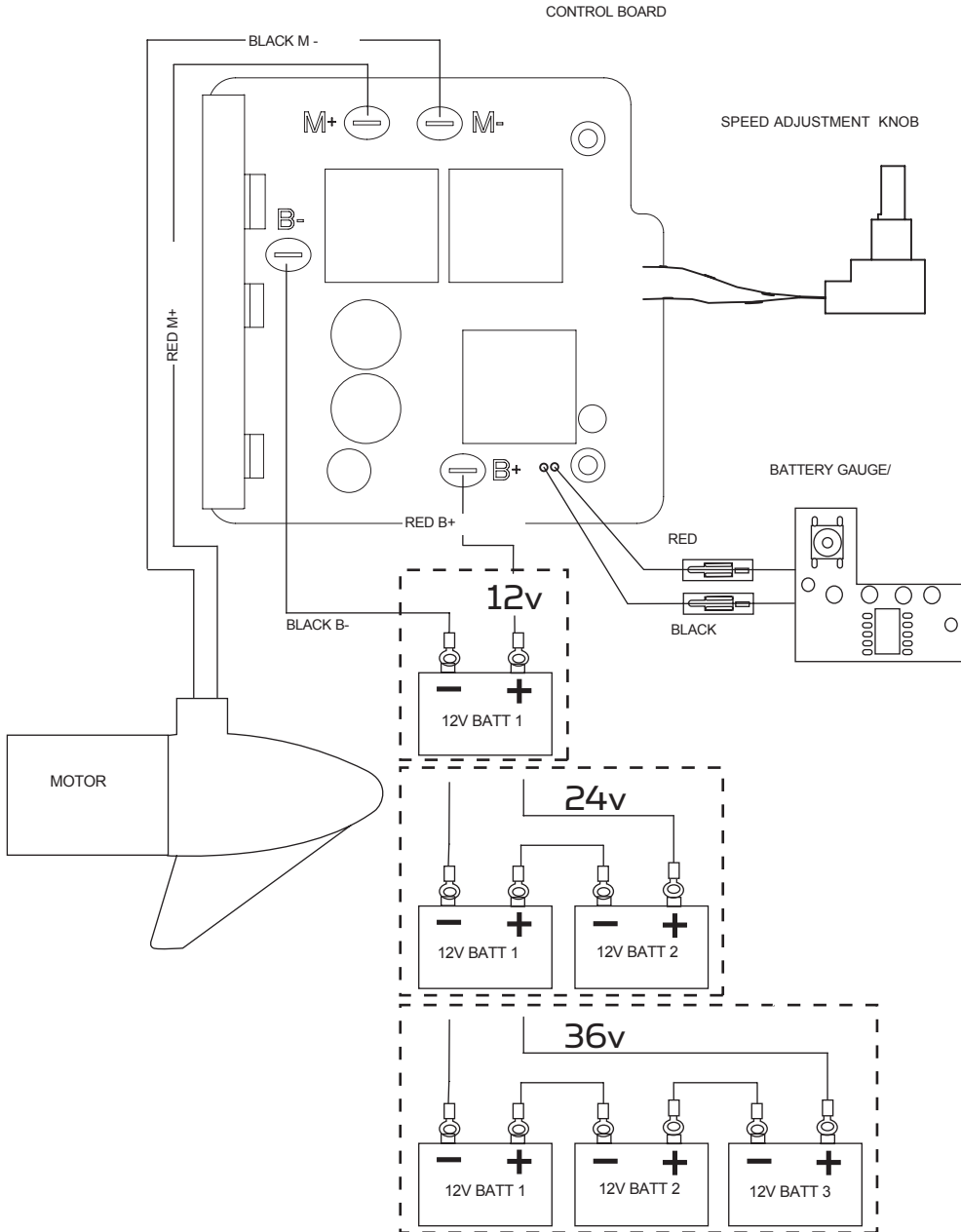

## BOAT RIGGING AND PRODUCT INSTALLATION:

For safety and compliance reasons, we recommend that you follow American Boat and Yacht Council (ABYC) standards when rigging your boat. Altering boat wiring should be completed by a qualified marine technician. The following specifications are for general guidelines only:

**CAUTION:** These guidelines apply to general rigging to support your Minn Kota motor. Powering multiple motors or additional electrical devices from the same power circuit may impact the recommended conductor gauge and circuit breaker size. If you are using wire longer than that provided with your unit, follow the conductor gauge and circuit breaker sizing table below. If your wire extension length is more than 25 feet we recommend that you contact a qualified marine technician.

**An over-current protection device (circuit breaker or fuse) must be used.** Coast Guard requirements dictate that each ungrounded current-carrying conductor must be protected by a manually reset, trip-free circuit breaker or fuse. The type (voltage and current rating) of the fuse or circuit breaker must be sized accordingly to the trolling motor used. The table below gives recommended guidelines for the circuit breaker sizing.

Reference:

United States Code of Federal Regulations: 33 CFR 183 - Boats and Associated Equipment

ABYC E-11: AC and DC Electrical Systems on Boats.

### \*Conductor Gauge and Circuit Breaker Sizing Table

Motor Thrust	Max Amp Draw	Circuit Breaker	Wire Extension Length				
			5 feet	10 feet	15 feet	20 feet	25 feet
30#	30	50 Amp @ 12 VDC	10 AWG	10 AWG	8 AWG	6 AWG	4 AWG
40#, 45#	42		10 AWG	8 AWG	6 AWG	4 AWG	4 AWG
50#, 55#	50	60 Amp @ 12 VDC	8 AWG	6 AWG	4 AWG	4 AWG	2 AWG
70#	42	50 Amp @ 24 VDC	10 AWG	10 AWG	8 AWG	8 AWG	6 AWG
80#	56	60 Amp @ 24 VDC	8 AWG	8 AWG	8 AWG	6 AWG	6 AWG
101#	46	50 Amp @ 36 VDC	8 AWG	8 AWG	8 AWG	8 AWG	8 AWG
112#	52	60 Amp @ 36 VDC	8 AWG	8 AWG	8 AWG	8 AWG	8 AWG
E-Drive	40	50 Amp @ 48 VDC	10 AWG	10 AWG	10 AWG	10 AWG	10 AWG

**\*The conductor and circuit breaker sizing table above is only valid for the following assumptions.**

1. No more than three (3) conductors are bundled together inside a sheath or conduit outside of engine spaces.
2. Each conductor has 105 degree C temp rated insulation.
3. No more than 5% voltage drop allowed at full motor power based on published product power requirements.

**PROPELLER REPLACEMENT:**

- Disconnect motor from battery prior to changing the propeller.
- Hold the propeller and loosen the prop nut with a pliers or a wrench.
- Remove prop nut and washer. If the drive pin is sheared/broken, you will need to hold the shaft steady with a screwdriver blade pressed into the slot on the end of the shaft.

- Turn the old prop to horizontal ( as illustrated ) and pull it straight off. If drive pin falls out, push it back in.
- Align new propeller with drive pin.
- Install prop washer and prop nut.
- Tighten prop nut 1/4 turn past snug. [25-35 inch lbs.] Be careful, over tightening can damage prop.

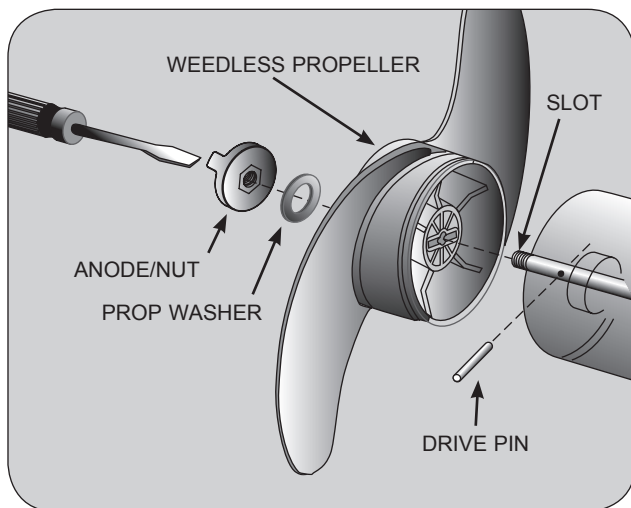

**CAUTION: DISCONNECT THE MOTOR FROM THE BATTERY BEFORE BEGINNING ANY PROP WORK OR MAINTENANCE.**

**MAXIMIZER™:**

The built-in Maximizer's electronics create pulse width modulation to provide longer running time and extended battery life. With the Maximizer speed control, you may, in some applications, experience interference in your depth finder display. We recommend that you

use a separate deep cycle marine battery for your trolling motor and that you power the depth finder from the starting / cranking battery.

## MAINTENANCE OF THE PRODUCT:

1. After use, these units should be rinsed with fresh water, then wiped down with a cloth dampened with an aqueous based silicone spray such as Armor All®.
2. The propeller must be cleaned of weeds and fishing line. The line can get behind the prop, wear away the seals and allow water to enter the motor. Check this after every 20 hours of operation.
3. Before each use, check to see that the prop nut is secure.
4. To prevent accidental damage during trailering or storage, disconnect the battery whenever the motor is off of the water. For prolonged storage, lightly coat all metal parts with an aqueous based silicone spray.
5. For maximum performance, restore battery to full charge before each use.
6. Keep battery terminals clean with fine sandpaper or

emery cloth.

7. The weedless wedge propeller is designed to provide absolute weed free operation with very high efficiency. To maintain this top performance, the leading edge of the blades must be kept smooth. If they are rough or nicked from use, restore to smooth by sanding with fine sandpaper.
8. Grease latch pins periodically to prevent binding or sticking.
9. The 5/16" Allen screw that attaches the motor to the mount should be periodically tightened to 10-12 ft lbs to prevent motor stowing problems. Tighten the Allen screw when the mount is in the deployed position.

---

## TROUBLESHOOTING:

1. Motor fails to run or lacks power:
  - Check battery connections for proper polarity.
  - Make sure terminals are clean and corrosion free. Use fine sandpaper or emery cloth to clean terminals.
  - Check battery water level. Add water if needed.
2. Motor loses power after a short running time:
  - Check battery charge, if low, restore to full charge.
3. Motor is difficult to steer:
  - Check steering cables for proper tension. Adjust as necessary.
4. You experience prop vibration during normal operation:
  - Remove and rotate the prop 180°. See removal instructions in prop section.
5. Unit difficult to deploy:
  - Lubricate latch pins. Stow and deploy motor a few times until latch pins latch freely.

6. Motor drains battery when not in use.

Motors equipped with the Maximizer control board will draw a small amount of current when connected to the battery, this is normal. To prevent battery drain disconnect power to the motor when the boat is not in use.

7. Lift-assist not functioning:

- Ensure lift-assist pin was installed prior to motor use.

8. Motor shaft falls to one side of the motor shaft yoke when stowing.

- The 5/16" Allen screw that attaches the motor to the mount should be periodically tightened to 10-12 ft/lbs. Tighten the Allen screw when the mount is in the deployed position.

**NOTE:** For all other malfunctions, see enclosed Authorized Service Center (ASC) listing for nearest ASC.

**ENVIRONMENTAL COMPLIANCE STATEMENT:**

It is the intention of Johnson Outdoors Marine Electronics, Inc. to be a responsible corporate citizen, operating in compliance with known and applicable environmental regulations, and a good neighbor in the communities where we make or sell our products.

**WEEE Directive:**

EU Directive 2002/96/EC "Waste of Electrical and Electronic Equipment Directive (WEEE)" impacts most distributors, sellers, and manufacturers of consumer electronics in the European Union. The WEEE Directive requires the producer of consumer electronics to take responsibility for the management of waste from their products to achieve environmentally responsible disposal during the product life cycle.

WEEE compliance may not be required in your location for electrical & electronic equipment (EEE), nor may it be required for EEE designed and intended as fixed or temporary installation in transportation vehicles such as automobiles, aircraft, and boats. In some European Union member states, these vehicles are considered outside of the scope of the Directive, and EEE for those applications can be considered excluded from the WEEE Directive requirement.

This symbol (WEEE wheelee bin) on product indicates the product must not be disposed of with other household refuse. It must be disposed of and collected for recycling and recovery of waste EEE. Johnson Outdoors Marine Electronics, Inc will mark all EEE products in accordance with the WEEE Directive. It is our goal to comply in the collection, treatment, recovery, and environmentally sound disposal of those products; however, these requirement do vary within European Union member states. For more information about where you should dispose of your waste equipment for recycling and recovery and/or your European Union member state requirements, please contact your dealer or distributor from which your product was purchased.

**Disposal:**

Minn Kota motors are not subject to the disposal regulations EAG-VO (electric devices directive) that implements the WEEE directive. Nevertheless never dispose of your Minn Kota motor in a garbage bin but at the proper place of collection of your local town council.

Never dispose of battery in a garbage bin. Comply with the disposal directions of the manufacturer or his representative and dispose of them at the proper place of collection of your local town council.

**RT112/SF**  
**112 LBS THRUST**  
**36 VOLT / 52 AMPS**  
**62" SHAFT**

This page provides MinnKota® WEEE compliance disassembly instructions. For more information about where you should dispose of your waste equipment for recycling and recovery and/or your European Union member state requirements, please contact your dealer or distributor from which your product was purchased.

**Tools required:** Flat head screw driver, Phillips screw driver, Socket set, Pliers, Wire cutters.

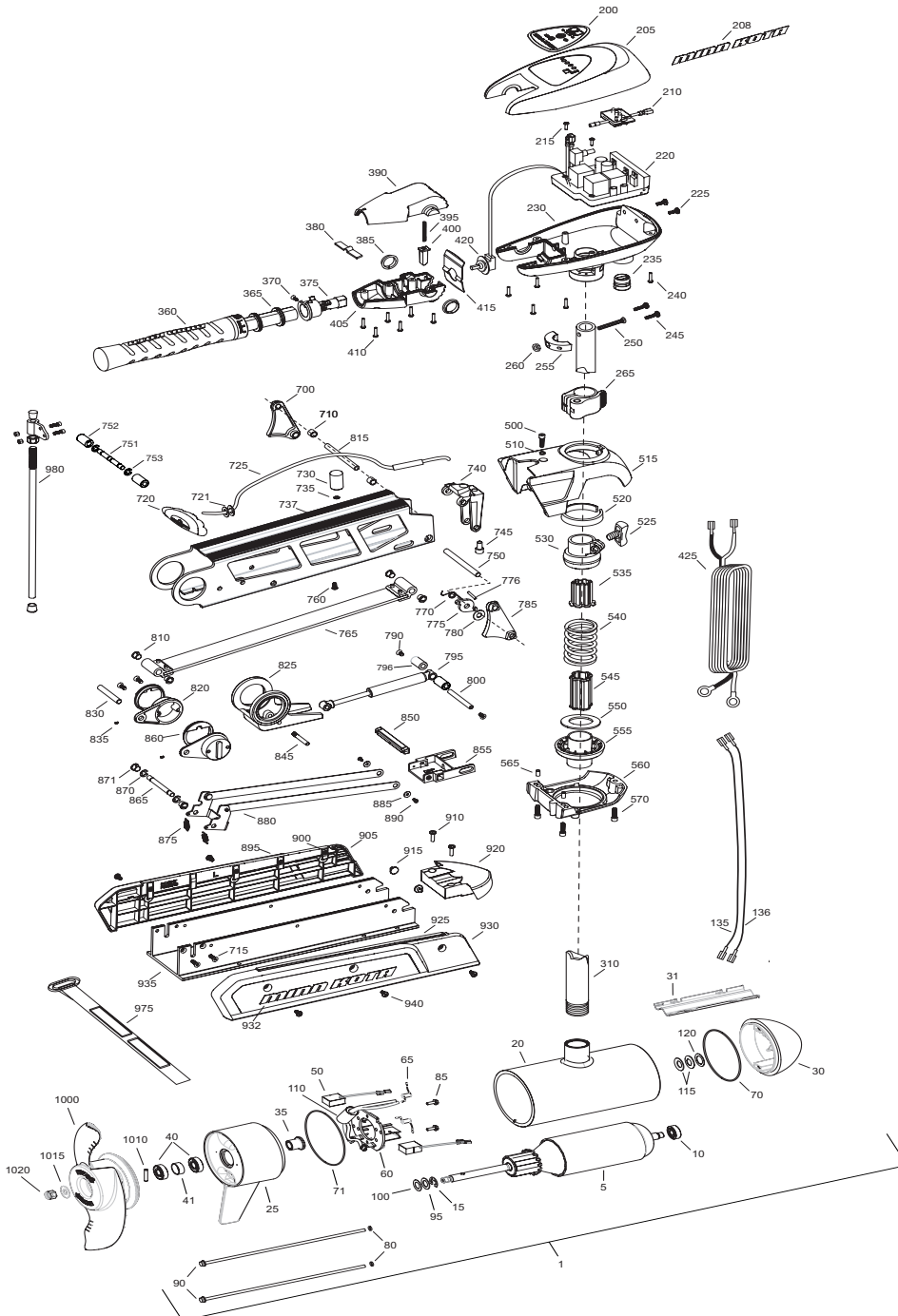



Item	P/N	Description	Qty	Item	P/N	Description	Qty
1	2317091	36V Motor 62" SW	1				
5	2-100-245	Armature assembly	1	■	2990957	Handle assy, VARS [360-410]	1
10	140-014	Bearing	1	360	2990456	Grip/handle assy, VARS [360-375]	1
15	788-040	Retaining ring	1	365	2060015	Bearing, handle	2
20	2-200-340	Center housing assembly	1	370	2063405	Screw, #6 PFH SS	1
25	2-300-151	Brush end housing assembly	1	375	2884092	Yoke / spider assy, VARS	1
30	421-241	Plain end housing assembly STD	1	380	2302742	Spring, detent, off	1
31	582-016	Retaining clip	1	385	2060005	Bearing, handle pivot	2
				390	2060900	Handle pivot, top	1
35	144-017	Flange bearing	1	395	2302745	Spring, release button	1
40	880-025	Seal	2	400	2063700	Button, release	1
41	725-095	Paper tube - seal bore	1	405	2060905	Handle pivot, bottom	1
50	188-095	Brush	2	410	2303412	Screw, #6 x 5/8 SS	6
60	9-738-011	Brush plate assembly	1	415	2062715	Spring, handle pivot	1
65	975-045	Brush spring	2	420	2061700	Washer, pot holder	1
■	2881450	Seal and O-ring Kit [40, 70-80]		425	2992521	Leadwire assy	1
70	701-098	O-ring, plain end	1				
71	701-107	O-ring, brush end	1	■	2991757	Bowguard Assembly SW [500-570]	1
80	701-009	O-ring, thru-bolt	2	500	2283414	Screw, 5/16-18 SHCS, RIE	1
85	2053410	Screw, 10-32 x 1/2"	2	510	2281700	Washer, 5/16 highcollar lock	1
90	830-094	Thru-bolt 12-24	2	515	2281953	Bowguard top	1
95	990-051	Washer, steel	1	520	2280001	Bearing, Bowguard top	1
100	990-052	Washer, nylatron	2	525	2011366	Knob, ss	1
110	2307312	Ferrite bead	1	530	2261525	Spring sleeve, upper	1
115	992-011	Washer, belleville	2	535	2264702	Tube insert, upper	1
120	990-011	Washer, shim	1	540	2262705	Spring, bowguard	1
135	640-045	Leadwire, black 62"	1	545	2282000	Tube insert, lower	1
136	640-145	Leadwire, red 62"	1	550	2281525	Spacer, lower spring	1
				555	2281520	Spring sleeve, lower	1
200	2095605	Decal, c-box cover 112#	1	560	2991729	Bowguard bottom	1
205	2060296	C-box cover	1	565	2282612	Pin-spring 5/16, SS	2
208	2325666	Decal - MinnKota	2	570	2283413	Screw, 3/8-16 SHCS, RIE	3
210	2074082	Battery meter, 36v SW	1				
215	3043427	Screw, #8 x 7/8 SS	2	■	2991751	Mt, Fortrex, long SW 62" [700-940]	1
220	2184017	Control board, 24/36V	1	700	2280800	Link, bowguard mount, left	1
■	2888411	Potentiometer Replacement Kit		710	2287303	Bushing, upper pins	2
225	2303434	Screw, #8-30 x 5/8 SS	2	715	2283409	Screw, 1/4-20 x 3/4 FHSC	4
230	2062503	Control box, VARS, SW	1	720	2880400	Pull grip assembly	1
235	2062905	Strain relief	1	721	2261732	Washer	2
240	2303412	Screw, #6 x 5/8 SS	6	725	2771601	Rope assembly	1
245	2263434	Screw, #8 x 1 SS	2	730	2281516	Spacer, inner arm	1
250	2383406	Screw, #10-24 x 2 SS	1	735	2281702	Washer, lock 1/4	1
255	2061517	Collar, c-box	1	737	2284212	Outer arm, long, 62"	1
260	2383101	Nut, 10-24, nylock, SS	1	740	2992302	Rope guide assembly	1
265	2991521	Cam lock/depth collar assy	1	745	2281530	Insert, threaded	1
				750	2282608	Pin, 7/16 x 5_5/32	1
310	2002015	Tube Composite 62"	1	751	2282602	Pin, 3/8 x 3_3/4	1
				752	2261505	Spacer	2
				753	2263011	E-ring, 3/8 shaft	2
				760	2223418	Screw, 1/4-20 x 1/2 BHCS	1
				765	2993821	Inner arm assembly, long, 62"	1
				770	2042711	Spring, torsion	1

\* This item is part of an assembly. This item cannot be sold separately due to machining and /or assembly that is required.

Item	P/N	Description	Qty
775	2283620	Latch, safety	1
776	2282611	Spring, safety latch	1
780	2281704	Washer 7/16 nylon	1
785	2280805	Link, bowguard mount, right	1
790	2283410	Screw 1/4-20 x 1/2 PFH	2
795	2288405	Gas spring (cylinder), 112#, long mt	1
796	2281710	Spacer, gas spring	2
800	2282610	Pin, upper, shock	1
810	2280005	Bearing, nyliner 7/16"	4
815	2282600	Pin, 7/16 x 4 7/8	1
820	2281932	Bracket, rear pivot	2
825	2281501	Yoke, shock mount	1
830	2282606	Pin, 7/16 x 4 1/2	1
835	2283402	Screw, set, 6-32 x 1/4	2
845	2282604	Pin, Knurled 5/16 x 2	1
850	2283615	Latch bar	1
855	2283610	Bracket - latch/strap, rope pull	1
860	2287300	Bushing, rear pivot	2
865	2282602	Pin, 3/8 x 3 3/4	1
870	2263011	E-ring, 3/8 shaft	2
871	2280008	Bearing, Iglide	2
875	2282720	Spring, extension	2
880	2773601	Latch strap assembly, Long	1
885	2261732	Washer 8, nylon	2
890	2373450	Screw 8-18 x 3/8	2
■	2993916	Sideplate assembly, long, left, sw	1
895	2288625	Support, left sideplate	1
900	2283408	Screw 8 x 3/8	8
905	2283916	Sideplate, long, left, sw	1
910	2073408	Screw 1/4-20 x 7/8	2
915	2286700	Plug, spacer	2
920	2283900	Ramp, motor	1
■	2993926	Sideplate assembly, long, right, sw	1
925	2288620	Support, right sideplate	1
930	2283926	Sideplate, long, right, sw	1
932	2285501	Decal, Sideplate, sw	2
935	2281912	Base extrusion, long, 62"	1
940	2323405	Screw 1/4-20 x 1/2	6
975	2773806	Strap hold down	1
980	2991925	Bracket stabilizer assembly	1
■	1378160	Propeller kit WW2 [1000-1020]	
■	2994876	Propeller bag assy [1010-1020]	
1000	2341160	Propeller WW2	1
1010	2262658	Drive pin, large	1
1015	2091701	Washer, prop, large	1
1020	2198401	Nut, nylock, prop, Anode	1
■	2994830	Bag assembly	1