



## CE Master User Manual for **MAXXUM**



PLEASE THOROUGHLY READ THIS USER MANUAL. FOLLOW ALL INSTRUCTIONS AND HEED ALL SAFETY & CAUTIONARY NOTICES BELOW. USE OF THIS MOTOR IS ONLY PERMITTED FOR PERSONS THAT HAVE READ AND UNDERSTOOD THESE USER INSTRUCTIONS. MINORS MAY USE THIS MOTOR ONLY UNDER ADULT SUPERVISION.

## MAXXUM OVERVIEW

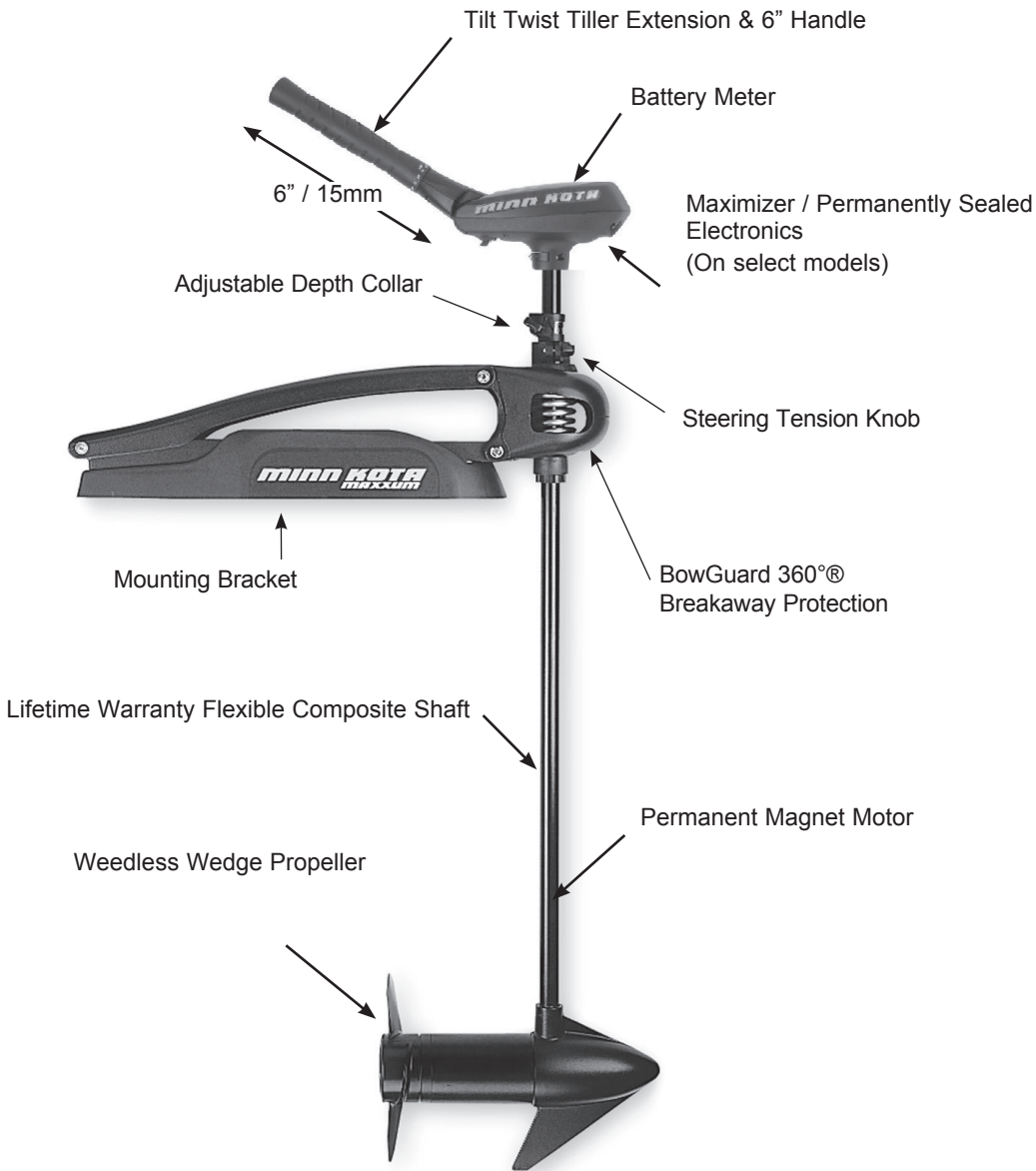

Specifications subject to change without notice.

**Attention:**

- Avoid running your motor with the propeller outside of the water. This may result in injuries from the rotating propeller.
- It is recommended to set the speed selector to zero and place the motor in the deployed position prior to connecting power cables. Disconnect power cables prior to stowing.
- Always ensure that the power cables are not twisted or kinked; and that they are securely routed to avoid a safety or trip hazard. Ensure cables are unobstructed in all locations to avoid damaging the wire insulation. Damage to the insulation could result in failure or injury.
- Always inspect the insulation of the power cables prior to use to ensure they are not damaged.
- Disregarding these safety precautions may result in an electrical short of the battery(s) and/or motor. Always disconnect the motor from the battery(s) before cleaning or checking the propeller.
- Avoid submerging the complete motor as water may enter the lower unit through control head and shaft. Water in the lower unit may cause an electrical short and damage the lower unit. This damage will not be covered by warranty.

**Caution!**

- Always operate the motor in a safe distance away from obstructions. Never approach the motor when the propeller is running. Contact with a spinning propeller may endanger you or others.
- Always exercise safe practices when using your motor; stay clear of other watercrafts, swimmers, and any floating objects. Always obey water regulations applicable to your area of operation.
- Never operate the motor while under the influence of alcohol, drugs, medication, or other substances which may impair your ability to safely operate equipment.
- This motor is not suitable for use in strong currents exceeding the thrust level of the motor.

The constant noise pressure level of the motor during use is less than 70dB(A). The overall vibration level does not exceed 2,5m/sec<sup>2</sup>.

## INSTALLATION OF THE BOWMOUNT:

We recommend that you have another person help with this procedure.

1. For installation, do not remove the shaft/motor from the Bowguard. The Bowguard spring is under tension and must always remain secured.
2. Place the mount, with the motor in the fully retracted (flat) position, on the deck of the boat:
  - The motor should be mounted as close to the centerline of the boat as possible.
  - Make sure bow area under the chosen location is clear and unobstructed for drilling.

- Make sure the motor rest is positioned far enough beyond the edge of the boat. The motor, as it is lowered into the water or raised into the boat, must not encounter any obstructions.

3. Once in position, mark at least four (4) of the holes provided in the bow plate and drill through the marks using a (9/32") bit.
4. Mount the plate to the bow through the drilled holes using the provided (1/4-20 x 3-1/2") bolts, nuts and washers.

**NOTE:** If possible, secure all sets of mounting bolts, nuts and washers.



**CAUTION: MAKE SURE YOUR MOTOR IS MOUNTED ON A LEVEL SURFACE**

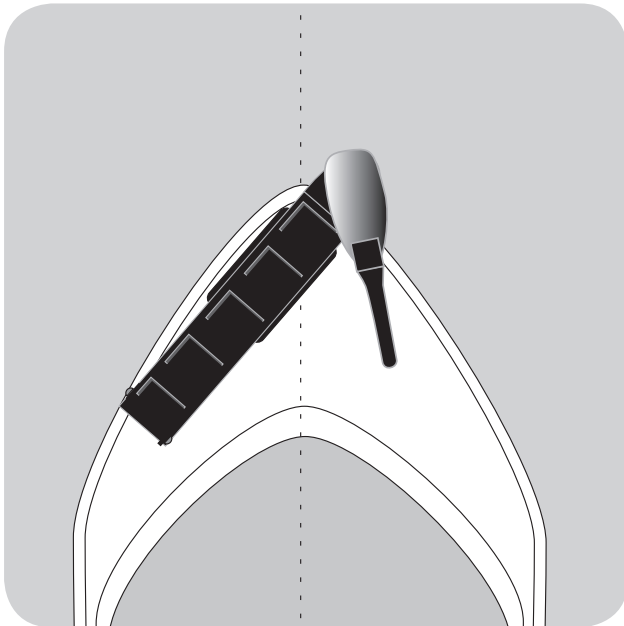

**Position the Bowmount close to the centerline of the boat and in an area free of obstructions.**

**BOW MOUNT OPERATION:**

- The bow mount is designed to fold back and lock the motor flat on deck when not in use.
- The motor rest positions the lower unit as it comes in contact with the nose of the mount and guides it onto the motor rest.
- The tube lock tilts up and engages the shaft to lock it for transport.
- The hold down strap assembly crosses over the shaft

and the rectangular ring / Velcro® secures the motor.

- Pull the rope to release the lock bar, which automatically engages when the unit is lowered or raised into position. The pull grip and rope should be used to both lower and raise the unit.
- If the rope disengages from the lock bar assembly, release the lock bar with a screwdriver.

**WARNING : WHEN RAISING OR LOWERING MOTOR, KEEP FINGERS CLEAR OF ALL HINGE AND PIVOT POINTS AND ALL MOVING PARTS.**

## OPERATION OF THE PRODUCT CONT'D:

### Tilt and Extension Handle Operation:

Your MAXXUM trolling motor features 7 usable handle tilt positions...45°, 30°, and 15° up and down from the 0° (horizontal) position. To use the down positions, you must first press the release button located on the left underside of the pivot handle.

Your MAXXUM trolling motor handle also features a unique stow position, that is useful for limiting the

amount of space required for storage or travel.

First press the release button located on the left underside of the pivot handle, then push the handle down until you feel the handle "lock in" to the stowed position. This will be almost parallel to the motor shaft.

To extend the handle, pull the handle towards you to the desired position. The handle will extend a full 6 inches. To retract, push the handle in until it meets the face of the motor control head.

**IMPORTANT: THE MOTOR MUST BE IN THE OFF POSITION TO USE THE STOW POSITION! FAILURE TO PUT THE MOTOR IN THE OFF POSITION BEFORE STOWING THE HANDLE WILL RESULT IN JOINT FAILURE.**

Handle controls on/off,  
steering, forward/reverse

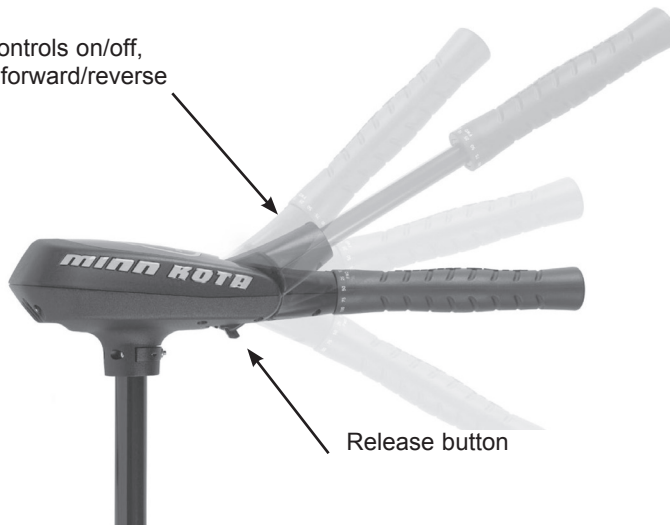

Release button

**CAUTION: NEVER OPERATE YOUR MOTOR WHEN IT IS OUT OF THE WATER.**

## OPERATION OF THE PRODUCT CONT'D:

### Depth Adjustment

- Firmly grasp the outer shaft or control head and hold it steady.
- Loosen depth setting knob on the hinge cover until the shaft slides freely.
- Raise or lower the motor to the desired depth.
- Turn the motor control head to the desired position.
- Tighten depth setting knob to secure the motor in place.

**NOTE:** When setting the depth be sure the top of the motor is submerged at least 12" to avoid churning or agitation of surface water. The propeller must be completely submerged.

### STEERING ADJUSTMENT:

- Adjust steering tension knob to provide enough tension to allow the motor to turn freely, yet remain in any position without being held or; Tighten the knob and lock the motor in a preset position to leave your hands free for fishing.





## BATTERY INFORMATION:

The motor will operate with any deep cycle marine 12 volt battery/batteries. For best results use a deep cycle, marine battery with at least a 115 ampere hour rating. As a general on the water estimate, your 12 volt motor will draw one ampere per hour and your 24 volt motor will draw .75 ampere per hour for each pound of thrust produced when the motor is running on high. The actual ampere draw is subject to your particular power environmental conditions and operation requirements. Maintain battery at full charge. Proper care will ensure having battery power when you need it, and will significantly improve the battery life. Failure to recharge lead-acid batteries (within 12-24 hours) is the leading cause of premature battery failure. Use a variable rate charger to avoid overcharging. If you are using a crank battery to start a gasoline outboard, we recommend that you use a separate deep cycle marine battery/batteries for your Minn Kota trolling motor.

Advice regarding batteries:

**Never connect the (+) and the (-) terminals of the battery together. Take care that no metal object can fall onto the battery and short the terminals. This would immediately lead to a short and utmost fire danger.**

Recommendation: Use battery boxes and covered battery terminal clamps like Minn Kota accessory #MK-BC-1.

These motors are equipped with a "push to test" battery gauge. The LED provides an accurate display of the remaining charge in the battery. It is only accurate when the motor is off. The gauge reads as:

- Four lights indicate full charge.
- Three lights indicate good charge.
- Two lights indicate low charge.
- One light indicates recharge.



## BOAT RIGGING AND MOTOR INSTALLATION:

**An over-current protection device (circuit breaker or fuse) must be used with this motor.** Coast Guard requirements dictate that each ungrounded current-carrying conductor must be protected by a manually reset, trip-free circuit breaker or fuse. The type (voltage and current rating) of the fuse or circuit breaker must be sized accordingly to the trolling motor used. The following breaker sizes are recommended guidelines:

### Maximum thrust Voltage Recommended circuit breaker rating

30# to 45# 12V 50A @ 12VDC

50# to 55# 12V 60A @ 12VDC

65# to 70# 24V 50A @ 24VDC

80# 24V 60A @ 24VDC

101# 36V 50A @ 36VDC

E-Drive 48V 40A @ 48VDC

The appropriate wire size needed to connect your trolling motor to the trolling motor batteries varies depending on the length of cable needed and voltage of the motor. For additional information, please consult appropriate ABYC (American Boat and Yacht Council) and Coast Guard requirements.

### Reference:

United States Code of Federal Regulations: 33 CFR 183 – Boats and Associated Equipment

ABYC E-11: AC and DC Electrical Systems on Boats

## BATTERY CONNECTION

### 12 Volt Systems:

1. Make sure that the motor is switched off (speed selector on "0").
2. Connect positive (+) red lead to positive (+) battery terminal.
3. Connect negative (-) black lead to negative (-) battery terminal.
4. For safety reasons do not switch the motor on until the propeller is in the water.

### 24 Volt Systems:

1. Make sure that the motor is switched off (speed selector on "0").
2. Two 12 volt batteries are required.
3. The batteries must be wired in series, only as directed in wiring diagram, to provide 24 volts.
  - a. Connect a connector cable to positive (+) terminal of battery 1 and to negative (-) terminal of battery 2.
  - b. Connect positive (+) red lead to positive (+) terminal on battery 2.
  - c. Connect negative (-) black lead to negative (-) terminal of battery 1.
4. For safety reasons do not switch the motor on until the propeller is in the water.

### 36 Volt Systems:

1. Make sure that the motor is switched off (speed selector on "0").
2. Three 12 volt batteries are required.
3. The batteries must be wired in series, only as directed in wiring diagram, to provide 36 volts.
  - a. Connect a connector cable to positive (+) terminal of battery 1 and to negative (-) terminal of battery 2.
  - b. Connect a connector cable to positive (+) terminal of battery 2 and to negative (-) terminal of battery 3.
  - c. Connect positive (+) red lead to positive (+) terminal on battery 3.
  - d. Connect negative (-) black lead to negative (-) terminal of battery 1.
4. For safety reasons do not switch the motor on until the propeller is in the water.

If installing a leadwire plug, observe proper polarity and follow instructions in your boat owner's manual.

See wiring diagram on following pages.

- **IMPROPER WIRING OF 24 VOLT SYSTEM COULD CAUSE BATTERY EXPLOSION!**
- **KEEP LEADWIRE WING NUT CONNECTION TIGHT AND SOLID TO BATTERY TERMINALS.**
- **LOCATE BATTERY IN A VENTILATED COMPARTMENT.**

# 12-24 VOLT 5 SPEED MODELS

THIS IS A UNIVERSAL MULTI-VOLTAGE DIAGRAM. DOUBLE CHECK YOUR MOTORS VOLTAGE FOR PROPER CONNECTIONS

Over-Current Protection Devices not shown in illustrations.

## FIVE SPEED SWITCH

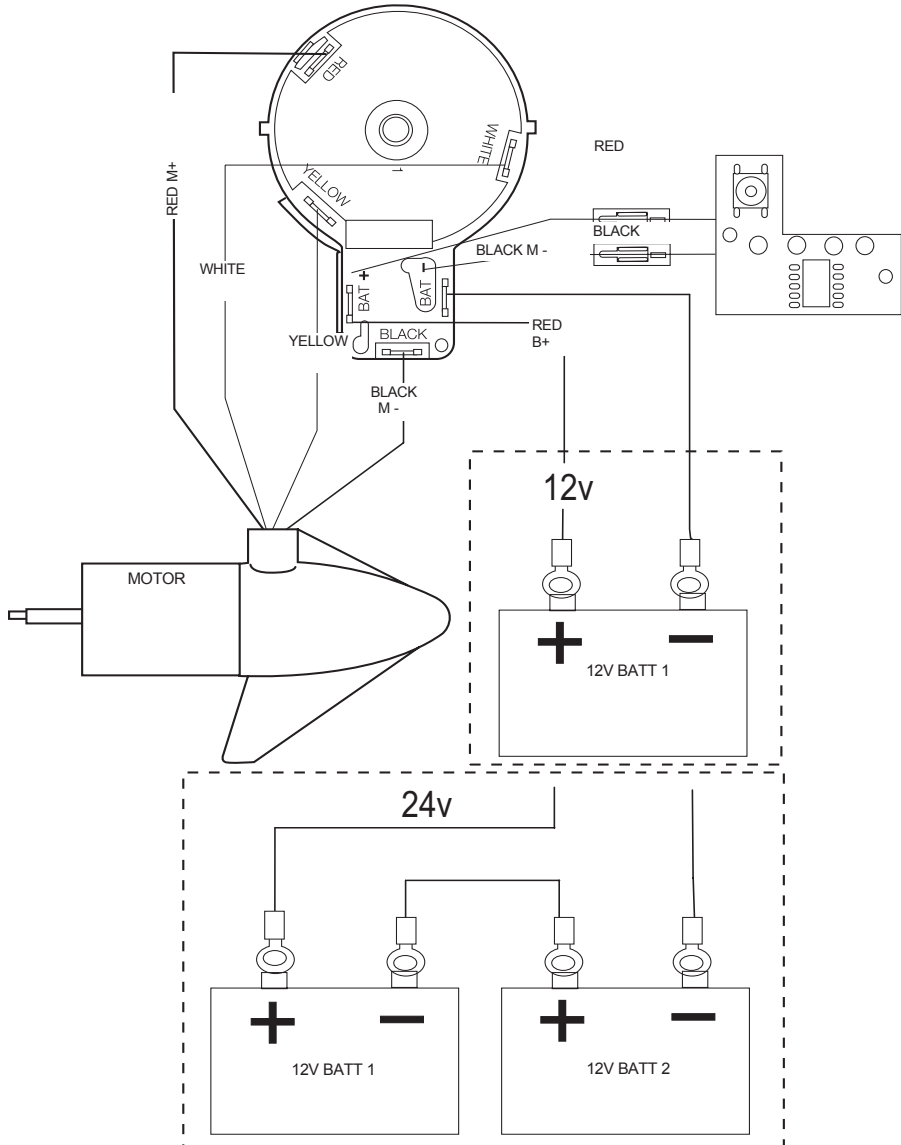

**PROPELLER REPLACEMENT:**

- Disconnect motor from battery prior to changing the propeller.
- Hold the propeller and loosen the prop nut with a pliers or a wrench.
- Remove prop nut and washer. If the drive pin is sheared/broken, you will need to hold the shaft steady with a

screwdriver blade pressed into the slot on the end of the shaft.

- Turn the old prop to horizontal ( as illustrated ) and pull it straight off. If drive pin falls out, push it back in.
- Align new propeller with drive pin.
- Install prop washer and prop nut.
- Tighten prop nut 1/4 turn past snug. [25-35 inch lbs.] Be careful, over tightening can damage prop.

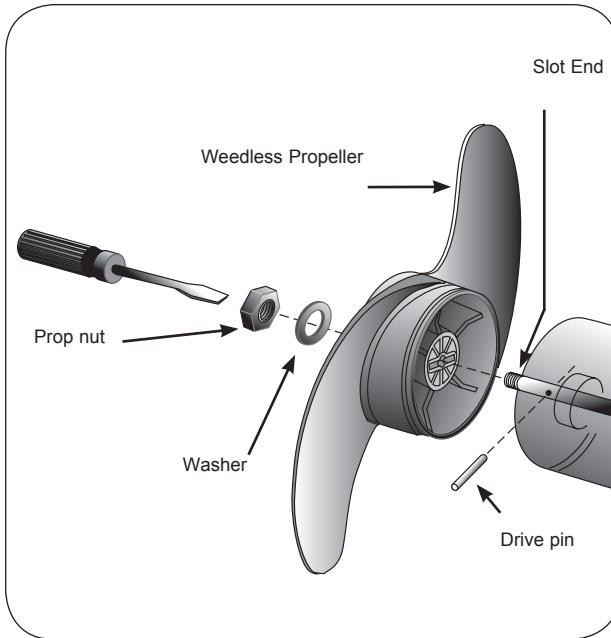

**CAUTION: DISCONNECT THE MOTOR FROM THE BATTERY BEFORE BEGINNING ANY PROP WORK OR MAINTENANCE.**

## MAINTENANCE OF THE PRODUCT:

1. After use, these units should be rinsed with fresh water, then wiped down with a cloth dampened with an aqueous based silicone spray such as Armor All®. This series of motors is not equipped for salt water exposure.
2. The propeller must be cleaned of weeds and fishing line. The line can get behind the prop, wear away the seals and allow water to enter the motor. Check this after every 20 hours of operation.
3. Before each use, check to see that the prop nut is secure.
4. To prevent accidental damage during trailering or storage, disconnect the battery whenever the motor is off of the water. For prolonged storage, lightly coat all metal parts with an aqueous based silicone spray.
5. For maximum performance, restore battery to full charge before each use.
6. Keep battery terminals clean with fine sandpaper or emery cloth.
7. The weedless wedge propeller is designed to provide absolute weed free operation with very high efficiency. To maintain this top performance, the leading edge of the blades must be kept smooth. If they are rough or nicked from use, restore to smooth by sanding with fine sandpaper.

---

## TROUBLESHOOTING:

1. Motor fails to run or lacks power:
    - Check motor for obstructions. The motor may have gone into current limit. To reset: return to off position, remove obstruction and resume operation.
    - Failure to put the motor in the off position before stowing the handle will result in joint failure.
    - Check battery connections for proper polarity.
    - Make sure terminals are clean and corrosion free. Use fine sandpaper or emery cloth to clean terminals.
    - Check battery water level. Add water if needed.
  2. Motor loses power after a short running time:
    - Check battery charge, if low, restore to full charge.
  3. Motor is hard to steer:
    - Loosen the steering tension knob on the top of bracket.
    - Lubricate the composite shaft.
  4. Bracket shifts or “walks” on transom:
    - With some boats, the transom bracket may loosen or shift during heavy use.
  5. You experience prop vibration during normal operation:
    - Remove and rotate the prop 180°. See removal instructions in prop section.
- NOTE:** For all other malfunctions, see enclosed authorized service center listing for nearest service center.

## ENVIRONMENTAL COMPLIANCE STATEMENT:

It is the intention of Johnson Outdoors Marine Electronics, Inc. to be a responsible corporate citizen, operating in compliance with known and applicable environmental regulations, and a good neighbor in the communities where we make or sell our products.

### WEEE Directive:

EU Directive 2002/96/EC "Waste of Electrical and Electronic Equipment Directive (WEEE)" impacts most distributors, sellers, and manufacturers of consumer electronics in the European Union. The WEEE Directive requires the producer of consumer electronics to take responsibility for the management of waste from their products to achieve environmentally responsible disposal during the product life cycle.

WEEE compliance may not be required in your location for electrical & electronic equipment (EEE), nor may it be required for EEE designed and intended as fixed or temporary installation in transportation vehicles such as automobiles, aircraft, and boats. In some European Union member states, these vehicles are considered outside of the scope of the Directive, and EEE for those applications can be considered excluded from the WEEE Directive requirement.

This symbol (WEEE wheellie bin) on product indicates the product must not be disposed of with other household refuse. It must be disposed of and collected for recycling and recovery of waste EEE. Johnson Outdoors Marine Electronics, Inc. will mark all EEE products in accordance with the WEEE Directive. It is our goal to comply in the collection, treatment, recovery, and environmentally sound disposal of those products; however, these requirements do vary within European Union member states. For more information about where you should dispose of your waste equipment for recycling and recovery and/or your European Union member state requirements, please contact your dealer or distributor from which your product was purchased.



### Disposal:

Minn Kota motors are not subject to the disposal regulations EAG-VO (electric devices directive) that implements the WEEE directive. Nevertheless never dispose of your Minn Kota motor in a garbage bin but at the proper place of collection of your local town council.

Never dispose of battery in a garbage bin. Comply with the disposal directions of the manufacturer or his representative and dispose of them at the proper place of collection of your local town council.

**MAXXUM 55/SC/HC**  
**55 LBS THRUST**  
**12 VOLT**  
**52" SHAFT**

This page provides MinnKota® WEEE compliance disassembly instructions. For more information about where you should dispose of your waste equipment for recycling and recovery and/or your European Union member state requirements, please contact your dealer or distributor from which your product was purchased.

**Tools required:** Flat Head screw driver, Phillips screw driver, Socket set, Pliers, wire Cutters.

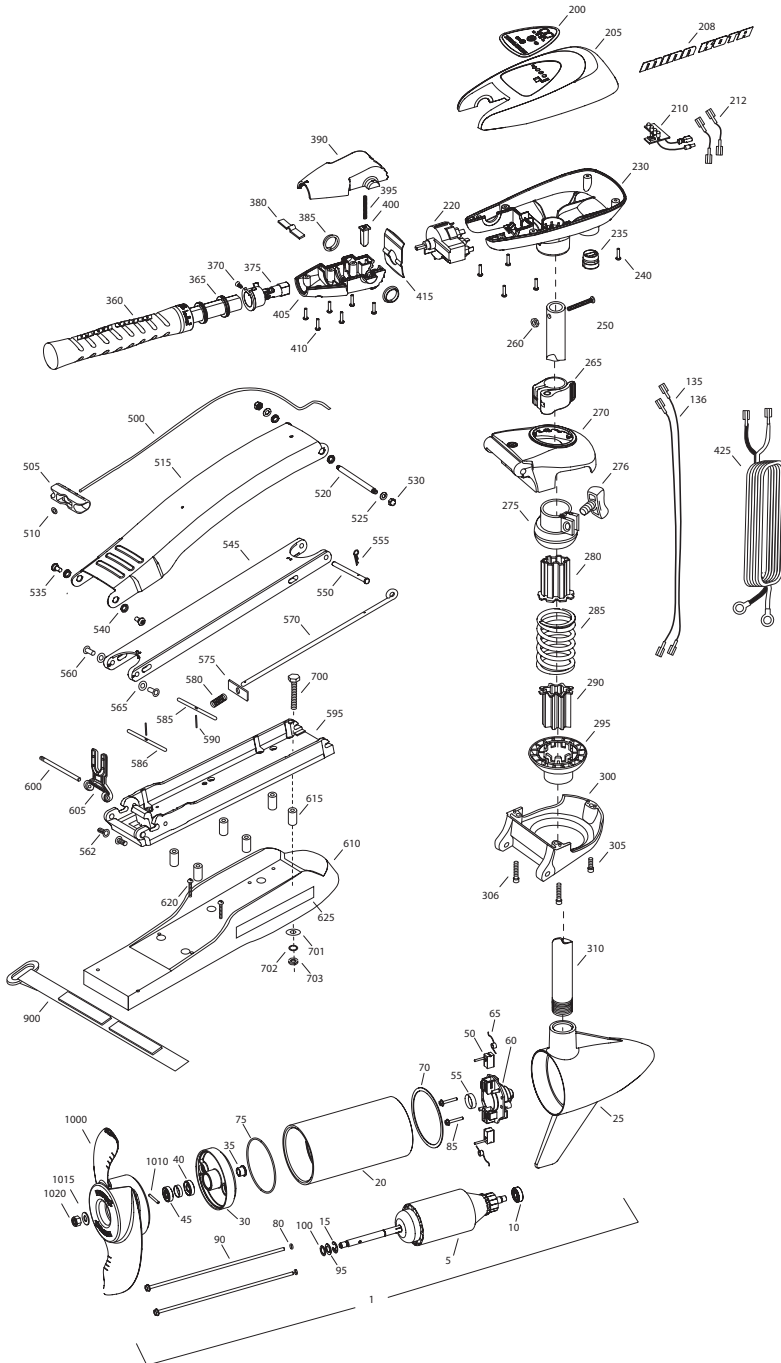



Item	P/N	Description	Qty	Item	P/N	Description	Qty	Item	P/N	Description	Qty	Item	P/N	Description	Qty
1	2097087	12V Motor 36" FW	1	360	2990451	Grip/handle assy, 5SPD [360-375]	1								
5	2-100-121	Armature assembly	1	365	2060015	Bearing, handle	2	■	1378131	Propeller kit WW2					
10	140-010	Bearing	1	370	2063405	Screw, #6 PFH SS	1	■	2994875	Propeller bag assy					
15	788-015	Retaining ring	1	375	2884091	Yoke / spider assy, 5SPD	1	1000	2091160	Propeller WW2	1				
20	2-200-101	Center housing assembly	1	380	2302742	Spring, detent, off	1	1010	2092600	Drive pin, small	1				
25	2-300-199	Brush end housing assembly	1	385	2060005	Bearing, handle pivot	2	1015	2151726	Washer, prop, small	1				
30	2-400-101	Plain end housing assembly	1	390	2060900	Handle pivot, top	1	1020	2053101	Nut, nylock, prop, small	1				
35	144-049	Flange bearing	1	395	2302745	Spring, release button	1								
40	880-003	Seal	1	400	2063700	Button, release	1								
45	880-006	Seal with shield	1	405	2060905	Handle pivot, bottom	1								
50	188-036	Brush	2	410	2303412	Screw, #6 x 5/8 SS	6								
55	725-050	Paper tube	1												
60	738-036	Brush plate assembly	1	415	2062715	Spring, handle pivot	1								
65	975-040	Brush spring	2	425	2992523	Leadwire assy	1								
70	337-036	Gasket	1												
75	701-081	O-ring, motor	1	■	2991840	Mount, Bow Assy W/ Bowguard	1								
80	701-008	O-ring, thru-bolt	2			[270-306], [500-625]									
85	830-007	Screw, 8-32	2	500	2251601	Rope	1								
90	830-042	Thru-bolt	2	505	2150400	Pull grip	1								
95	990-067	Washer, steel	2	510	2151700	Washer	1								
100	990-070	Washer, nylon	2	515	2264241	Arm, upper, std, fw	1								
135	640-006	Leadwire, black	1	520	2262605	Pin, bowguard, upper	1								
136	640-115	Leadwire, red	1	525	9908236	Washer, 1/4", ZP	2								
■	2888460	Seal and O-ring Kit		530	2223100	Nut, 5/16-18 SS	2								
				535	2263500	Bolt, shoulder	2								
200	2185613	Decal, c-box cover	1	540	2293501	Bushing, SS	2								
205	2060295	C-box cover	1	545	2994307	Arm, Lower, std, fw	1								
208	2325685	Decal - Minnkota	2	550	2262607	Pin, clevis ZP	1								
210	2074070	Battery meter, 12v FW	1	555	2260805	Spring, clip	1								
212	2070304	Wire, battery meter blk, 7"	1	560	2261318	Bushing, nylon	2								
				562	2261540	Insert-threaded bowplate	2								
220	2064028	Switch 5 speed	1	565	2261708	Washer, spacer, .010 thk	2								
230	2062505	Control box, 5 SPD, FW	1	570	2153602	Eyeshaft, ZP	1								
235	2062905	Strain relief	1	575	2262703	Spring stop	1								
240	2303412	Screw, #6 x 5/8 SS	6	580	2152700	Spring, lock bar	1								
250	2383407	Screw, #10-24 x 2 SS	1	585	2233622	Lock bar, front, ZP	1								
260	2383124	Nut, 10-24, nylock, SS	1	586	2233620	Lock bar, back, ZP	1								
265	2991521	Cam lock/depth collar assy	1	590	2152610	Spring pin	2								
				595	2773987	Bowplate w/ insert, std, fw	1								
■	2991760	Bowguard Assembly [270-306]	1	600	2260506	Hinge pin, ZP	1								
270	2261976	Bracket, top	1	605	2293811	Yoke, Max	1								
275	2261525	Spring sleeve, Upper	1	610	2263912	Motor rest, std, fw	1								
276	2011365	Knob, collar	1	615	2261505	Spacer, motor rest	6								
280	2264702	Tube insert, bowmount	2	620	2263434	Screw, #8, SS	2								
285	2262711	Spring, bowguard	1	625	2265514	Decal, motor rest	2								
295	2261535	Spring sleeve, Lower	1												
300	2991775	Bracket Assy, bottom	1	■	2994830	Bag assembly	1								
305	2263423	Screw, 5/16 x 1" SHCS ZP	1	700	2263431	Screw, 1/4-20 x 3 1/2" PPH, SS	6								
306	2263425	Screw, 5/16 x 2.5" SHCS ZP	2	701	2301720	Washer, rubber mounting	6								
				702	2261713	Washer, 1/4 SS	6								
310	2032068	Tube Composite 52"	1	703	2263101	Nut, 1/4-20 Nylock, SS	6								
■	2990956	Handle assy, 5SPD [360-410]	1	900	2263804	Strap, hold down	1								

\* This item is part of an assembly. This item cannot be sold separately due to machining and/or assembly that is required.