



Master User Manual for **FORTREX**

BOWMOUNT BOWGUARD 360®
FOOT CONTROL LIFT ASSIST
TROLLING MOTOR



PLEASE THOROUGHLY READ THIS USER MANUAL. FOLLOW ALL INSTRUCTIONS AND HEED ALL SAFETY & CAUTIONARY NOTICES BELOW. USE OF THIS MOTOR IS ONLY PERMITTED FOR PERSONS THAT HAVE READ AND UNDERSTOOD THESE USER INSTRUCTIONS. MINORS MAY USE THIS MOTOR ONLY UNDER ADULT SUPERVISION.

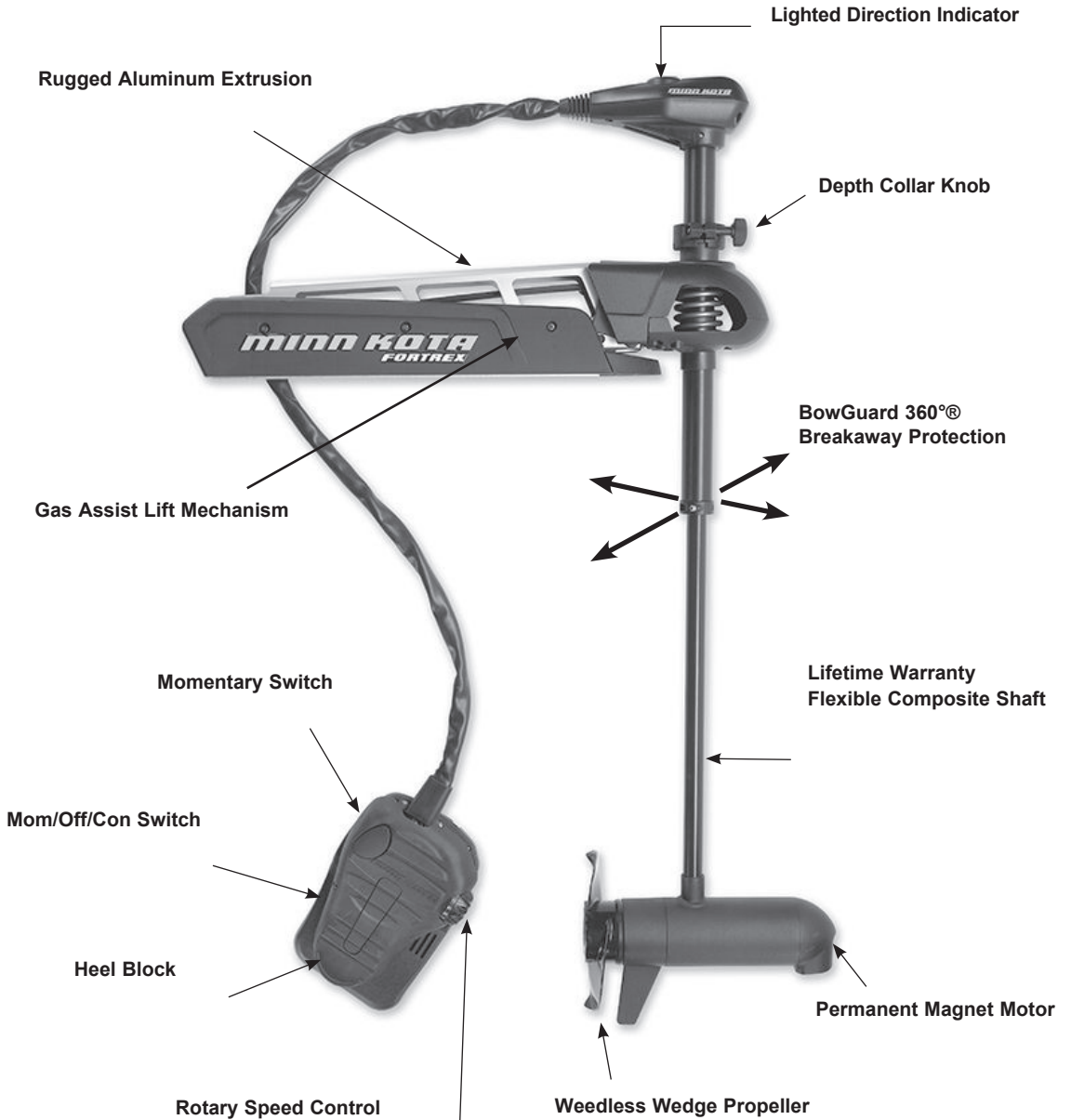

Specifications subject to change without notice.

ASSEMBLY OF MOTOR TO MOUNT:

1. Place the mount on an elevated surface such as a work-bench or tailgate of pickup.
2. Remove the 5/16" Allen screw and lock washer from the mount using an Allen wrench. (See picture)
3. Align the key ways on the inside of the bowguard with the ends links on the mount. Lower the motor assembly straight down until seated.
4. Install the 5/16" Allen screw / lock washer and tighten to 10-12 ft/lbs.
5. Stow the motor into the flat position by pulling the rope/handle to disengage the latch bar, allowing the motor to fold into the flat position.
6. Once in the stowed or flat position, the gas spring pin can be installed. Follow the steps below to install the gas spring pin and spacers:
 - Locate the upper gas spring pin and spacers in bag assembly

- Align the end of the gas spring with the holes in the outer arm
- Install pin, spacers and Phillips flat head screws
- Tighten screws until the heads are flush with the outer arm

NOTE: Screws have a pre-applied thread locker, DO NOT apply additional thread locker to screws as that may prevent future removal.

7. Motor / mount can now be installed onto the boat. Proceed to next page for mounting instructions.

ATTENTION: The 5/16" Allen screw must be tight when installed and periodically tightened to 10-12 ft/lbs (Step 4), which will allow the motor to be stowed properly. Tighten the Allen screw when the mount is in the deployed position.

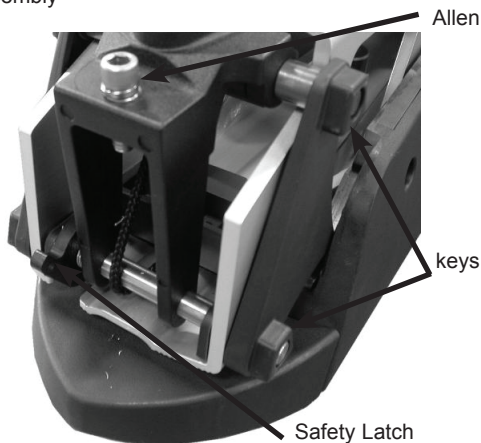

INSTALLATION OF THE BOWMOUNT:

We recommend that you have another person help with this procedure.

1. For installation, do not remove the shaft/motor from the Bowguard. The Bowguard spring is under tension and must always remain secured.
2. Place the mount, with the motor in the fully retracted (flat) position, on the deck of the boat:
 - The motor should be mounted as close to the centerline of the boat as possible.
 - Make sure bow area under the chosen location is clear and unobstructed for drilling.
 - Make sure the motor rest is positioned far enough beyond the edge of the boat. The motor, as it is lowered into the water or raised into the boat, must not encounter any obstructions.
3. Once in position, determine which bolt pattern is to be used (see below), mark at-least 4 of the holes in the bow

plate and drill through with a 9/32" drill bit. Either pattern may be used when installing the motor.

Pattern 1. Minnkota 3" bolt pattern standard motors.

Pattern 2. Alternate 4" bolt pattern commonly used.

NOTE: If pattern 2 is to be used, the right side plate must be removed to access the mounting holes in the bow plate.

4. Install Velcro strap between the motor and deck of boat between second and third set of mounting holes.
5. Mount the plate to the bow through the drilled holes using the provided (1/4-20 x 3-1/2") bolts, nuts and washers.

NOTE: If possible, secure all sets of mounting bolts, nuts and washers.

6. Install the bow mount stabilizer (if included). See page 5 for installation instructions.

CAUTION: MAKE SURE YOUR MOTOR IS MOUNTED ON A LEVEL SURFACE

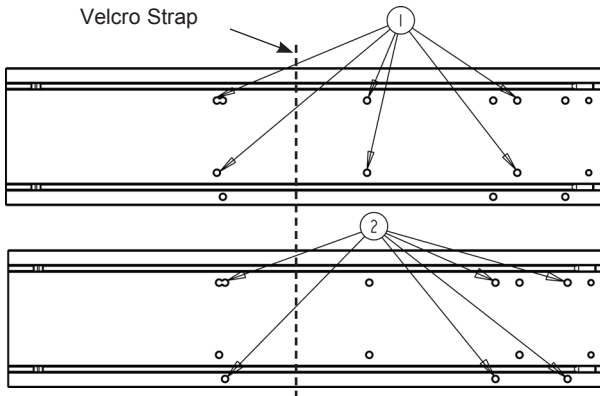

Position the Bowmount close to the centerline of the boat and in an area free of obstructions.

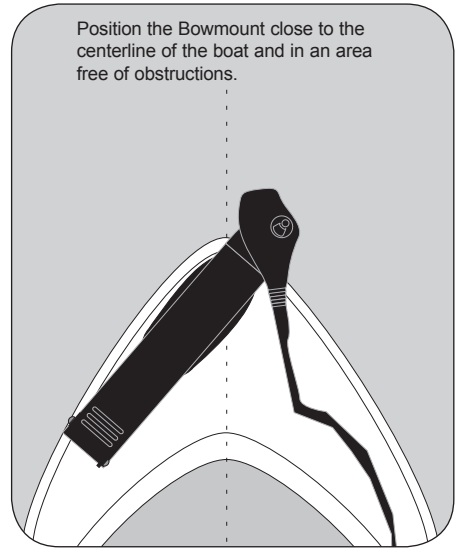

INSTALLING THE BOWMOUNT STABILIZER: (if Included)

1. Place motor in the stowed position
2. Unthread the composite rod from the bracket and attach bracket to the bottom of the bowguard using the 5/16" cap screws and nuts. The nuts fit into pocket on the inside of the bowguard behind the spring.

NOTE: The bracket can be installed on the left or right side of the bowguard.

3. Pull the bumper off the stabilizer rod and place the rod next to the bracket as shown in photo.
4. Place the threaded end down onto the deck surface and mark the rod 3/4" above the top of the bracket (see photo)
5. Cut the rod to the mark and round the cut edge with a file or sandpaper.
6. Install the bottom bumper to the stabilizer rod and thread the rod into the bracket.
7. Adjust the stabilizer rod up or down so that the tip **just** touches the support surface. See photo below.

WARNING: Adjusting the rod too tightly removes the end play needed for proper pin engagement and doing so could prevent the mount from fully latching in the stowed position. If installed correctly, the rod tip should lift off the deck about 1/4" without the mount unlatching.

8. Once adjusted, tighten the jam nut against the bracket, which will prevent the rod from turning.
9. Install top cap if threads are exposed.

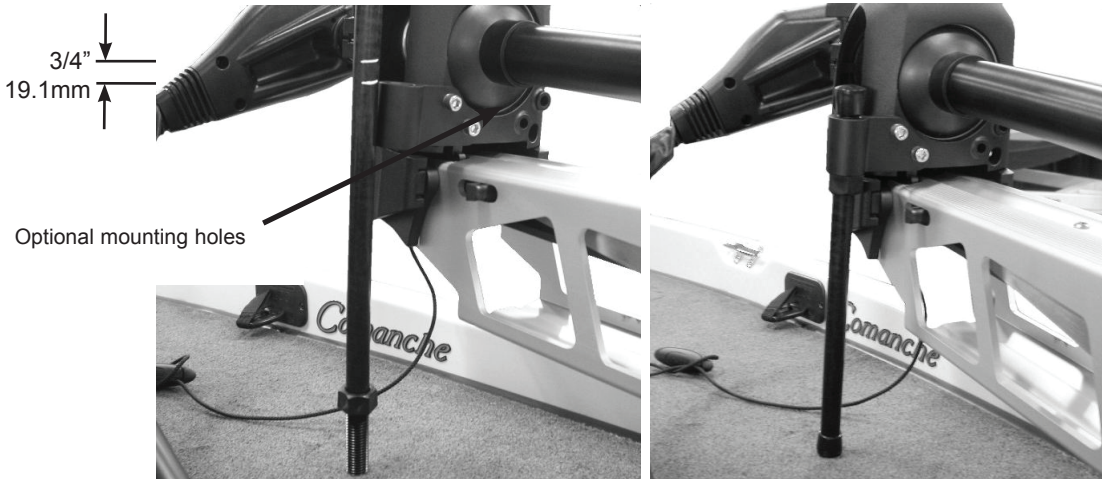

GAS ASSIST LIFT MECHANISM:

WARNING: The gas assist lift mechanism in this unit is under **HIGH SPRING PRESSURE** when the motor is in the deployed position. **DO NOT** remove the BowGuard assembly from the mount without disconnecting one end of the gas spring. Failure to do this can create a condition where accidental pulling of the rope may cause the mount to spring open rapidly, striking anyone or anything in the direct path.

To disconnect one end of the gas spring, follow the instructions below:

1. With the mount in the stowed position, locate the upper cylinder pin.
2. Using two Phillips screwdrivers, remove 1 of the Phillips flat head screws.
3. Remove pin and spacers from outer arm.
4. Now it is safe to deploy the motor and remove the motor assembly.
5. To re-connect the gas spring, see page 3, step 6.

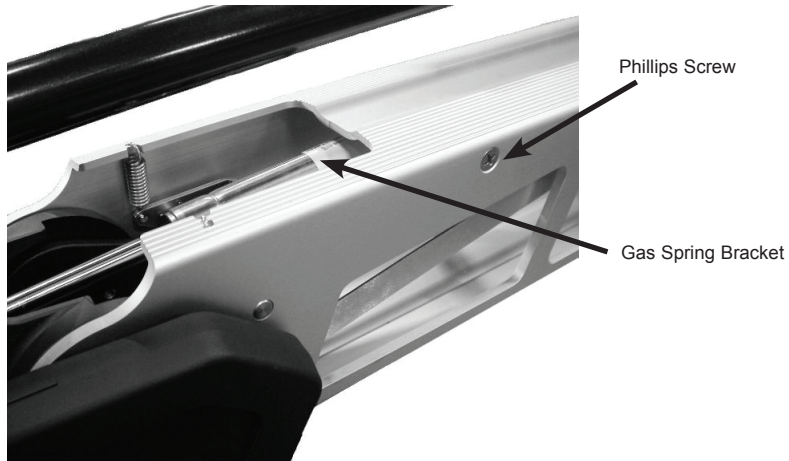

REMOVAL OF THE BOWGUARD:

WARNING: The gas assist lift mechanism in this unit is under HIGH SPRING PRESSURE when the motor is in the deployed position. DO NOT remove the BowGuard assembly from the mount without disconnecting one end of the gas spring.

1. Disconnect one end of the gas spring. see page 6 for instructions.
2. Place the motor in the deployed position.
3. Remove the 5/16" cap screw and lock washer located on the top of the bowguard, in front of the pull rope.
4. Lift motor/Bowguard assembly straight up until bowguard is free from mount.

NOTE: Rope and latch bar should never be pulled with the motor removed as the assembly is under HIGH PRESSURE.

5. **To re-assemble:** Align the key ways on the inside of the bowguard with the ends links on the mount. Lower the assembly straight down until seated Re-install the 5/16" cap screw and washer and tighten.



Allen Screw

WARNING

MOVING PARTS CAN CRUSH OR CUT

•GAS ASSIST LIFT MECHANISM IS UNDER PRESSURE

•DISCONNECT GAS SPRING BEFORE REMOVING MOTOR FROM MOUNT

•DO NOT PULL ROPE UNTIL GAS SPRING IS DISCONNECTED

FOOT PEDAL CONTROLS:

Most controls on the remote foot pedal are easy to operate by either foot or hand:

- Rotary Speed Control. These motors offer infinitely variable speeds. Turn the knob clockwise to increase speed and counter-clockwise to decrease speed.
- MOM / OFF / CON Switch. When depressed to CON, the “constant on” allows you to run continuously without keeping your foot on the pedal. Depress the switch MOM for momentary operation or to OFF.
- Momentary Switch. With the MON / OFF / CON set to “MOM”, a toe touch on the “momentary” switch turns the motor on. Let up and the motor stops.
- Right /Left. Push the toe end of the foot rest down to turn right and push the heel end of the foot rest down to turn left. Watch the lighted indicator on the motor head to check direction.
- Forward/Reverse. The motor always drives forward by depressing the constant on or momentary switch. You can reverse the direction of thrust by turning the motor 180°.

CAUTION: SWITCH THE MOM / OFF / CON CONTROL TO OFF WHEN NOT IN USE. IF THE MOTOR CONTROL IS LEFT ON AND THE PROPELLER ROTATION IS BLOCKED, SEVERE MOTOR DAMAGE CAN RESULT. **TROLLING MOTOR WILL DEplete BATTERY IF SWITCH IS LEFT IN MOM (MOMENTARY) OR CON (CONTINUOUS) POSITION.**

BOW MOUNT OPERATION:

The bowmount is designed to fold back and lock the motor flat on the deck when not in use and to provide secure stowage for transport.

- The pull rope releases the lock bar, which automatically engages when the unit is lowered or raised into position. The pull grip and rope should be used to both lower and raise the unit.
- The motor rest positions the lower unit as it comes in contact with the nose of the mount and guides it onto the motor rest.

WARNING : WHEN RAISING OR LOWERING MOTOR, KEEP FINGERS CLEAR OF ALL HINGE AND PIVOT POINTS AND ALL MOVING PARTS.

WARNING: WHEN INCLUDED WITH MOTOR, THE VELCRO STRAP AND STABILIZER MUST BE USED WHEN MOTOR IS IN THE STOWED POSITION.
FAILURE TO INSTALL AND USE THESE SUPPLIED PARTS MAY RESULT IN DAMAGE TO THE MOTOR NOT COVERED BY THE PRODUCT WARRANTY.

DEPTH ADJUSTMENT:

- Firmly grasp the outer shaft or control head and hold it steady.
- Loosen the depth setting knob on the depth collar until the shaft slides freely.
- Raise or lower the motor to the desired depth.
- Turn the motor control head to the desired position.
- Tighten depth setting knob to secure the motor in place.

NOTE: When setting the depth be sure the top of the motor is submerged at least 12" to avoid churning or agitation of surface water. The propeller must be completely submerged.

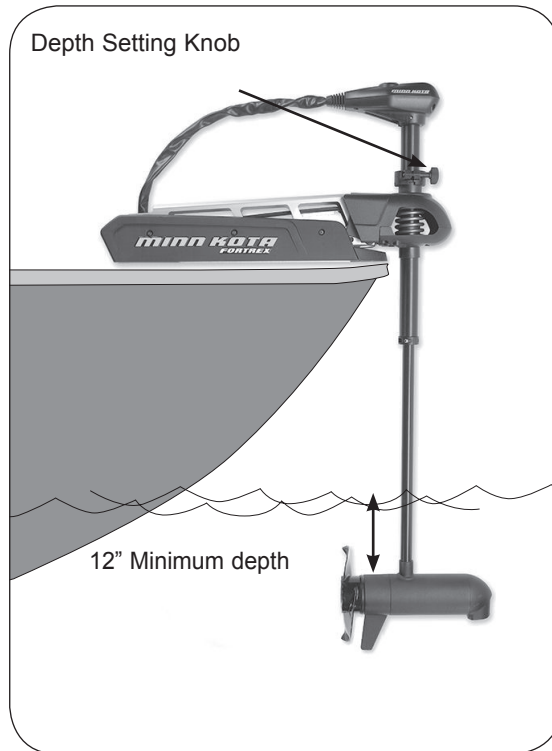

CABLE ADJUSTMENT:

The steering cable tension is pre-set at the factory but will, through normal use, need occasional adjustment. Adjust the tension by turning the Phillips screw located near the bottom of the foot pedal, just under the steering cable cover.

Turn the screw clockwise to increase tension and counter-clockwise to decrease tension.

NOTE: If the cable becomes too loose, it may disengage for either the roller drum in the control box or the pulley in the foot pedal.

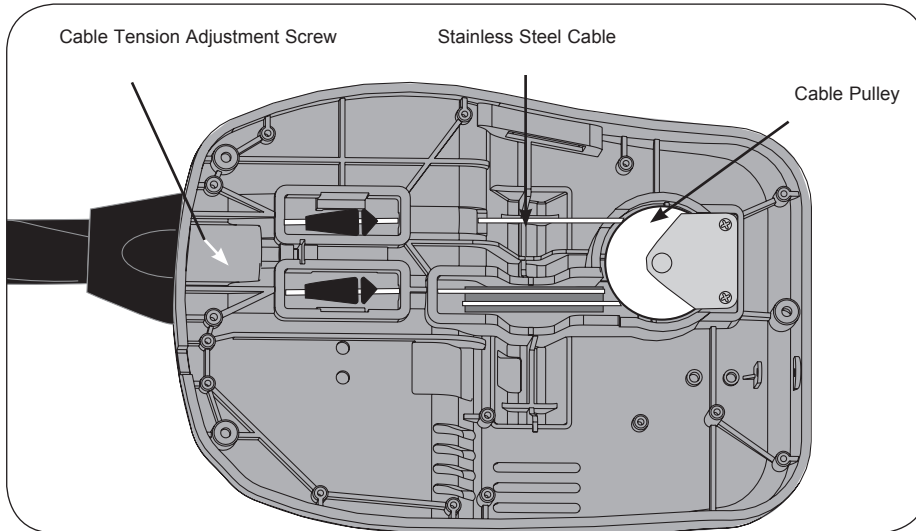

Attention:

- Avoid running your motor with the propeller out of the water. This may result in injuries from the rotating propeller.
- It is recommended to set the speed selector to zero and place the motor in the deployed position prior to connecting power cables.
- Always ensure that the power cables are not twisted or kinked; and that they are securely routed to avoid a safety or trip hazard. Ensure cables are unobstructed in all locations to avoid damaging the wire insulation. Damage to the insulation could result in failure or injury.
- Always inspect the insulation of the power cables prior to use to ensure they are not damaged.
- Disregarding these safety precautions may result in an electrical short of the battery(s) and/or motor. Always disconnect the motor from the battery(s) before cleaning or checking the propeller.
- Avoid submerging the complete motor as water may enter the lower unit through control head and shaft. Water in the lower unit may cause an electrical short and damage the lower unit. This damage will not be covered by warranty.

Caution!

- Always operate the motor in a safe distance away from obstructions. Never approach the motor when the propeller is running. Contact with a spinning propeller may endanger you or others.
- Always exercise safe practices when using your motor; stay clear of other watercrafts, swimmers, and any floating objects. Always obey water regulations applicable to your area of operation.
- Never operate the motor while under the influence of alcohol, drugs, medication, or other substances which may impair your ability to safely operate equipment.
- This motor is not suitable for use in strong currents exceeding the thrust level of the motor.

The constant noise pressure level of the motor during use is less than 70dB(A). The overall vibration level does not exceed 2,5m/sec².

BATTERY INFORMATION:

The motor will operate with any deep cycle marine 12 volt battery (two 12 volt batteries wired in series for 24 volt motors or three 12 volt batteries wire in series for 36 volt motors). For best results use a deep cycle, marine battery with at least a 115 ampere hour rating. Maintain batteries at full charge. Proper care will ensure having battery power when you need it and will significantly improve the battery life. Failure to recharge lead-acid batteries (within 12-24 hours) is the leading cause of premature battery failure. Use a variable rate Minn Kota charger to avoid overcharging.

If you are using a battery to start a gasoline outboard, we recommend that you use a separate deep cycle marine battery/batteries for your Minn Kota trolling motor.

Advice regarding batteries:

Never connect the (+) and the (-) terminals of the battery together. Take care that no metal object can fall onto the battery and short the terminals. This would immediately lead to a short and utmost fire danger.

BATTERY CONNECTION:**24 Volt Systems: FORTREX 80**

1. Make sure that the motor is switched off (speed selector on "0").
2. Two 12 volt batteries are required.
3. The batteries must be wired in series, only as directed in wiring diagram, to provide 24 volts.
 - a. Connect a connector cable to positive (+) terminal of battery 1 and to negative (-) terminal of battery 2.
 - b. Connect positive (+) red lead to positive (+) terminal on battery 2.
 - c. Connect negative (-) black lead to negative (-) terminal of battery 1.
4. For safety reasons do not switch the motor on until the propeller is in the water.

36 Volt Systems FORTREX 101 / 112

1. Make sure that the motor is switched off (speed selector on "0").
2. Three 12 volt batteries are required.
3. The batteries must be wired in series, only as directed in wiring diagram, to provide 36 volts.
 - a. Connect a connector cable to positive (+) terminal of battery 1 and to negative (-) terminal of battery 2.
 - b. Connect a connector cable to positive (+) terminal of battery 2 and to negative (-) terminal of battery 3.
 - c. Connect positive (+) red lead to positive (+) terminal on battery 3.
 - d. Connect negative (-) black lead to negative (-) terminal of battery 1.

4. For safety reasons do not switch the motor on until the propeller is in the water.

Note: Do not use your crank battery as one of the two or three supply batteries; crank batteries are not built for deep discharge service.

WARNING: • BEFORE CONNECTING BATTERY, MAKE SURE THE MOM/CON SWITCH IS IN THE OFF POSITION.

- IMPROPER WIRING OF 24 OR 36 VOLT SYSTEMS COULD CAUSE BATTERY EXPLOSION!
- KEEP LEADWIRE WING NUT CONNECTION TIGHT AND SOLID TO BATTERY TERMINALS.
- LOCATE BATTERY IN A VENTILATED COMPARTMENT.

THIS IS A UNIVERSAL MULTI-VOLTAGE DIAGRAM. DOUBLE CHECK YOUR MOTORS VOLTAGE FOR PROPER CONNECTIONS

Over-Current Protection Devices not shown in illustrations.

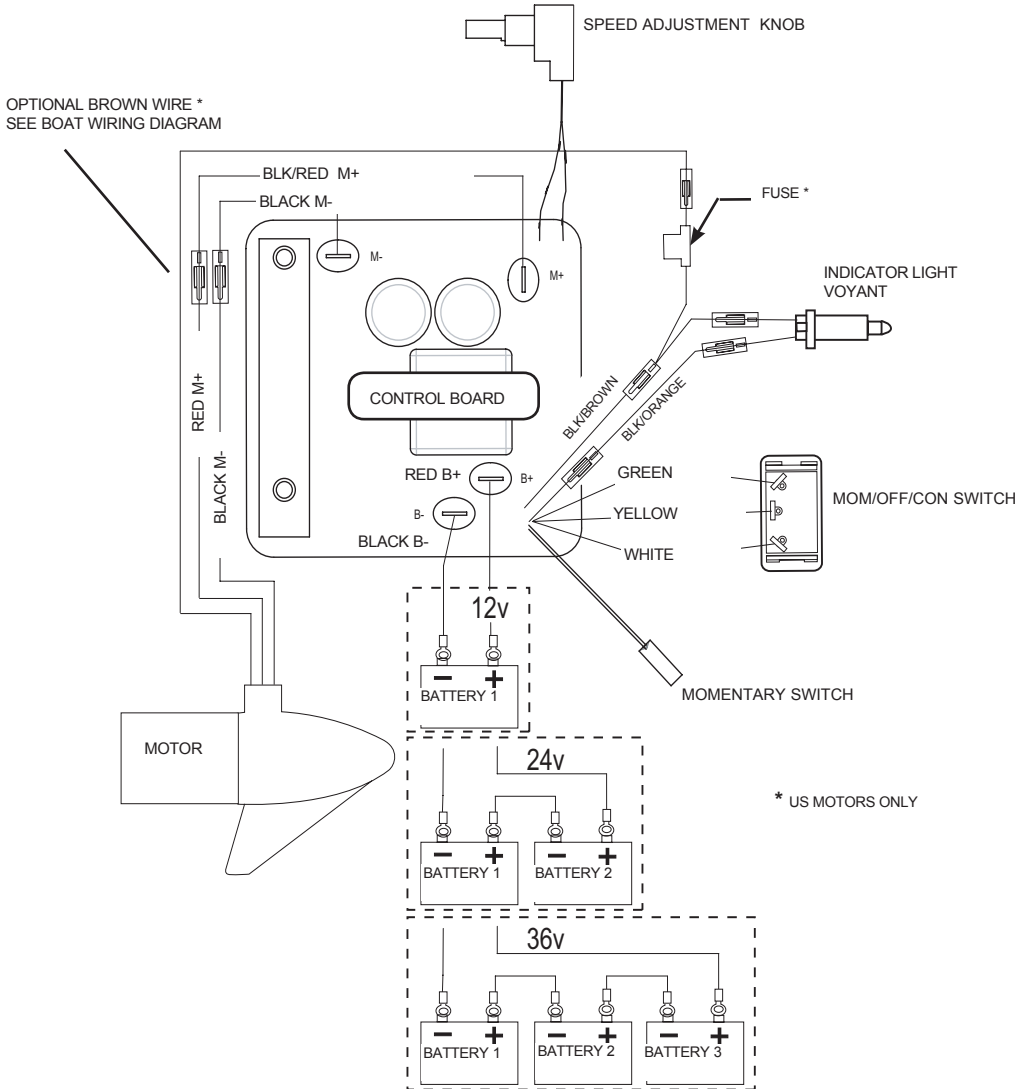

BOAT RIGGING AND PRODUCT INSTALLATION:

For safety and compliance reasons, we recommend that you follow American Boat and Yacht Council (ABYC) standards when rigging your boat. Altering boat wiring should be completed by a qualified marine technician. The following specifications are for general guidelines only:

CAUTION: These guidelines apply to general rigging to support your Minn Kota motor. Powering multiple motors or additional electrical devices from the same power circuit may impact the recommended conductor gauge and circuit breaker size. If you are using wire longer than that provided with your unit, follow the conductor gauge and circuit breaker sizing table below. If your wire extension length is more than 25 feet we recommend that you contact a qualified marine technician.

An over-current protection device (circuit breaker or fuse) must be used. Coast Guard requirements dictate that each ungrounded current-carrying conductor must be protected by a manually reset, trip-free circuit breaker or fuse. The type (voltage and current rating) of the fuse or circuit breaker must be sized accordingly to the trolling motor used. The table below gives recommended guidelines for the circuit breaker sizing.

Reference:

United States Code of Federal Regulations: 33 CFR 183 - Boats and Associated Equipment

ABYC E-11: AC and DC Electrical Systems on Boats.

*Conductor Gauge and Circuit Breaker Sizing Table

Motor Thrust	Max Amp Draw	Circuit Breaker	Wire Extension Length				
			5 feet	10 feet	15 feet	20 feet	25 feet
30#	30	50 Amp @ 12 VDC	10 AWG	10 AWG	8 AWG	6 AWG	4 AWG
40#, 45#	42		10 AWG	8 AWG	6 AWG	4 AWG	4 AWG
50#, 55#	50	60 Amp @ 12 VDC	8 AWG	6 AWG	4 AWG	4 AWG	2 AWG
70#	42	50 Amp @ 24 VDC	10 AWG	10 AWG	8 AWG	8 AWG	6 AWG
80#	56	60 Amp @ 24 VDC	8 AWG	8 AWG	8 AWG	6 AWG	6 AWG
101#	46	50 Amp @ 36 VDC	8 AWG	8 AWG	8 AWG	8 AWG	8 AWG
112#	52	60 Amp @ 36 VDC	8 AWG	8 AWG	8 AWG	8 AWG	8 AWG
E-Drive	40	50 Amp @ 48 VDC	10 AWG	10 AWG	10 AWG	10 AWG	10 AWG

***The conductor and circuit breaker sizing table above is only valid for the following assumptions.**

1. No more than three (3) conductors are bundled together inside a sheath or conduit outside of engine spaces.
2. Each conductor has 105 degree C temp rated insulation.
3. No more than 5% voltage drop allowed at full motor power based on published product power requirements.

PROPELLER REPLACEMENT:

- Disconnect motor from battery prior to changing the propeller.
- Hold the propeller and loosen the prop nut with a pliers or a wrench.
- Remove prop nut and washer. If the drive pin is sheared/broken, you will need to hold the shaft steady with a screwdriver blade pressed into the slot on the end of the shaft.
- Turn the old prop to horizontal (as illustrated) and pull it straight off. If the drive pin falls out, push it back in.
- Align new propeller with drive pin.
- Install prop washer and prop nut.
- Tighten prop nut 1/4 turn past snug. [25-35 inch lbs.] Be careful, over tightening can damage prop.

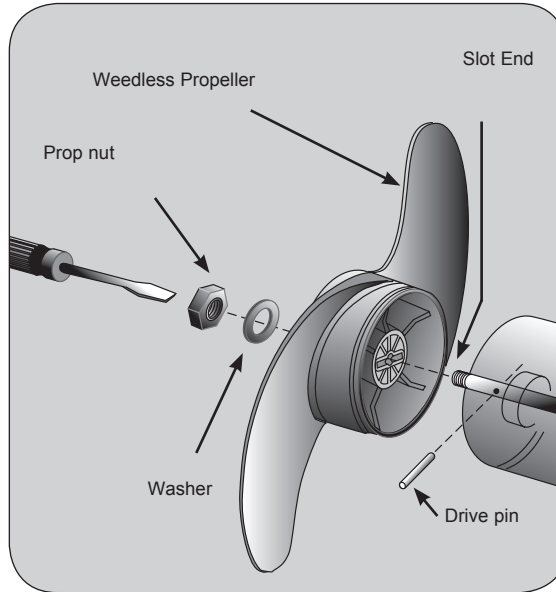

CAUTION: DISCONNECT THE MOTOR FROM THE BATTERY BEFORE BEGINNING ANY PROP WORK OR MAINTENANCE.

MAXIMIZER™: The built-In Maximizer's electronics create pulse width modulation to provide longer running time and extended battery life. With the Maximizer speed control, you may, in some applications, experience interference in your depth finder display. We recommend that you

use a separate deep cycle marine battery for your trolling motor and that you power the depth finder from the starting / cranking battery.

MAINTENANCE:

1. After use, these units should be rinsed with fresh water, then wiped down with a cloth dampened with an aqueous based silicone spray such as Armor All®. This series of motors is **not** equipped for salt water exposure.
2. The propeller must be cleaned of weeds and fishing line. The line can get behind the prop, damage the seals and allow water to enter the motor. Check this after every 20 hours of operation.
3. Before each use, check to see that the prop nut is secure.
4. To prevent accidental damage during trailering or storage, disconnect the battery whenever the motor is off of the water. For prolonged storage, lightly coat all metal parts with an aqueous based silicone spray.
5. For maximum performance, restore battery to full charge before each use.
6. Keep battery terminals clean with fine sandpaper or emery cloth.
7. The weedless wedge propeller is designed to provide absolute weed free operation with very high efficiency. To maintain this top performance, the leading edge of the blades must be kept smooth. If they are rough or nicked from use, restore to smooth by sanding with fine sandpaper.
8. Grease latch pins periodically to prevent binding or sticking.
9. The 5/16" Allen screw that attaches the motor to the mount should be periodically tightened to 10-12 ft/lbs to prevent motor stowing problems. Tighten the Allen screw when the mount is in the deployed position.

TROUBLESHOOTING:

1. Motor fails to run or lacks power:
 - Check battery connections for proper polarity.
 - Make sure terminals are clean and corrosion free. Use fine sandpaper or emery cloth to clean terminals.
 - Check battery water level. Add water if needed.
2. Motor loses power after a short running time:
 - Check battery charge, if low, restore to full charge.
3. Motor is difficult to steer:
 - Check steering cables for proper tension. Adjust as necessary.
4. You experience prop vibration during normal operation:
 - Remove and rotate the prop 180°. See removal instructions in prop section.
5. Unit difficult to deploy:
 - Lubricate the latch pins. Stow and deploy motor a few times until latch pins latch freely.
6. Motor drains battery when not in use.

Motors equipped with a Maximizer control board, will draw a small amount of current when connected to the battery, this is normal. To prevent battery drain, disconnect power to the motor when the boat is not in use.

7. Lift-assist not functioning:
 - Ensure lift-assist pin was installed prior to motor use.
8. Motor shaft falls to one side of the motor shaft yoke when stowing.
 - The 5/16" Allen screw that attaches the motor to the mount should be periodically tightened to 10-12 ft/lbs. Tighten the Allen screw when the mount is in the deployed position.

NOTE: For all other malfunctions, see enclosed authorized service center listing for nearest service center.

ENVIRONMENTAL COMPLIANCE STATEMENT:

It is the intention of Johnson Outdoors Marine Electronics, Inc. to be a responsible corporate citizen, operating in compliance with known and applicable environmental regulations, and a good neighbor in the communities where we make or sell our products.

WEEE Directive:

EU Directive 2002/96/EC "Waste of Electrical and Electronic Equipment Directive (WEEE)" impacts most distributors, sellers, and manufacturers of consumer electronics in the European Union. The WEEE Directive requires the producer of consumer electronics to take responsibility for the management of waste from their products to achieve environmentally responsible disposal during the product life cycle.

WEEE compliance may not be required in your location for electrical & electronic equipment (EEE), nor may it be required for EEE designed and intended as fixed or temporary installation in transportation vehicles such as automobiles, aircraft, and boats. In some European Union member states, these vehicles are considered outside of the scope of the Directive, and EEE for those applications can be considered excluded from the WEEE Directive requirement.

This symbol (WEEE wheelee bin) on product indicates the product must not be disposed of with other household refuse. It must be disposed of and collected for recycling and recovery of waste EEE. Johnson Outdoors Marine Electronics, Inc. will mark all EEE products in accordance with the WEEE Directive. It is our goal to comply in the collection, treatment, recovery, and environmentally sound disposal of those products; however, these requirement do vary within European Union member states. For more information about where you should dispose of your waste equipment for recycling and recovery and/or your European Union member state requirements, please contact your dealer or distributor from which your product was purchased.



Disposal:

Minn Kota motors are not subject to the disposal regulations EAG-VO (electric devices directive) that implements the WEEE directive. Nevertheless never dispose of your Minn Kota motor in a garbage bin but at the proper place of collection of your local town council.

Never dispose of battery in a garbage bin. Comply with the disposal directions of the manufacturer or his representative and dispose of them at the proper place of collection of your local town council.

FORTREX 80
80 LBS THRUST
24 VOLT / 52 AMP
52" & 62" SHAFT

This page provides MinnKota® WEEE compliance disassembly instructions. For more information about where you should dispose of your waste equipment for recycling and recovery and/or your European Union member state requirements, please contact your dealer or distributor from which your product was purchased.
Tools required but not limited to: Flat Head screw driver, Phillips screw driver, Socket set, Pliers, wire Cutters.

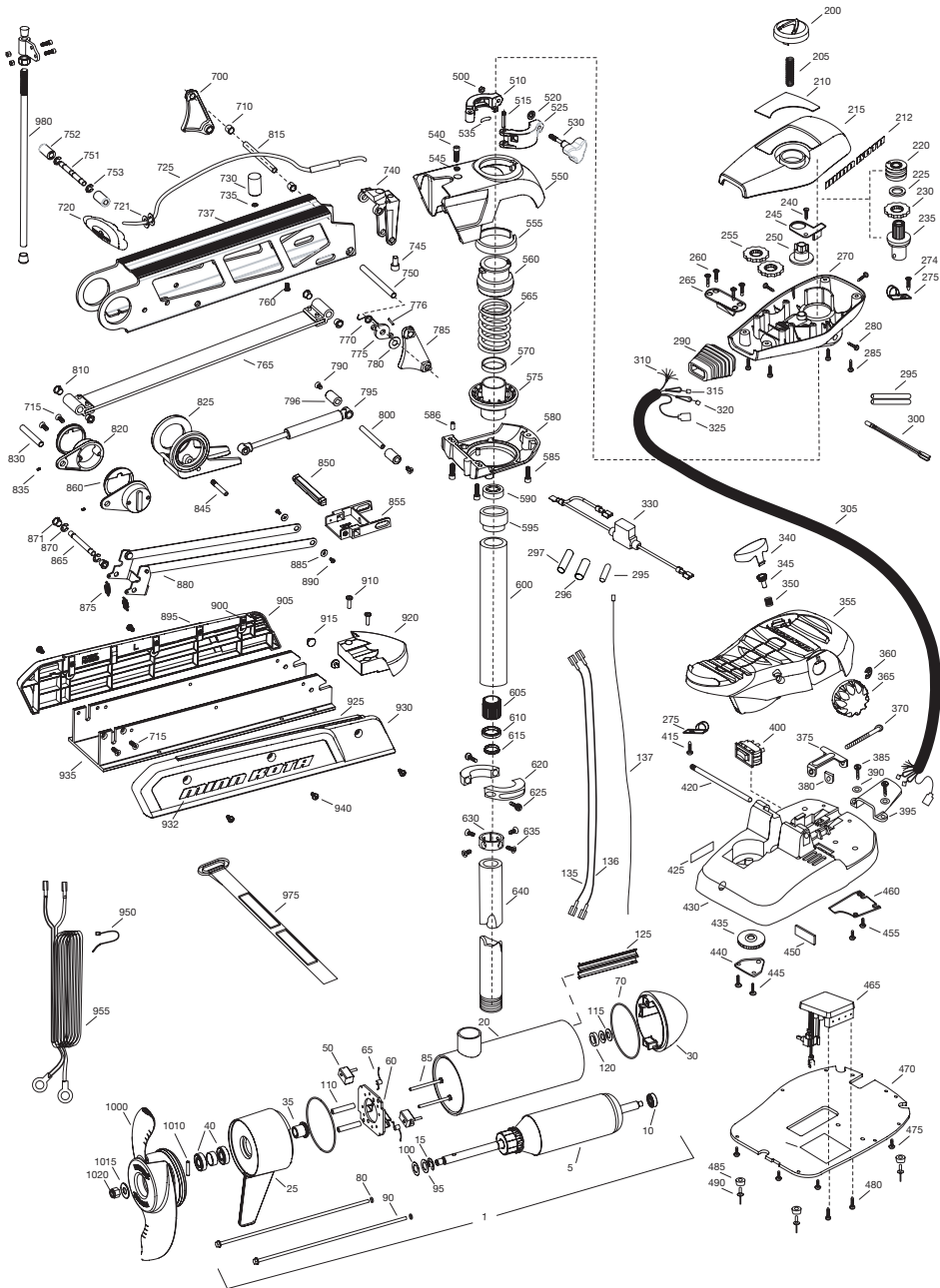

Item	P/N	Description	Qty	Item	P/N	Description	Qty
1	2316217	24V Motor 52" FW	1	296	2335400	Shrink Tube 1/2" OD x 2"	2
	2316219	24V Motor 62" FW	1	297	2375400	Shrink Tube 1/4" OD x 1 3/4"	1
	2326241	24V Motor US2 52"	1	300	2264015	Light, indicator	1
	2326242	24V Motor US2 62"	1	305	2265430	Cable jacket, 5'	1
5	2-100-214	Armature assembly	1	310	2261220	Wire harness, max	1
10	140-010	Bearing	1	315	2267505	Cable assembly, right, 5'	1
15	788-040	Retaining ring	1	320	2267515	Cably assembly, left, 5'	1
20	2-200-160	Center housing assembly		325	2211410	Cable extension, US2 175"	1
25	2-300-160	Brush end housing assembly	1	330	2218200	Fuse holder assembly US2 only	1
30	421-276	Plain end housing assembly STD	1	340	2993705	Push button w/ magnet	1
	9421-289	Plain end housing US2 52"	1	345	2260810	Clip, reed sensor	1
	9421-290	Plain end housing US2 62"	1	350	2302732	Spring, pedal button	1
35	144-017	Flange bearing	1	355	2994496	Foot pedal w/ plug	1
40	880-025	Seal	2	360	2263000	E-ring, knob	1
50	188-094	Brush	2	365	2280115	Knob, speed control VARS	1
60	9-738-004	Brush plate assembly	1	370	2263466	Screw 1/4-20 x 2	1
65	975-041	Brush spring	2	375	2263210	Bracket, conduit adjustment	1
70	701-043	O-ring, motor	2	380	2263140	Nylock keeper	1
80	701-009	O-ring, thru-bolt	2	385	2372100	Screw 8-18 x 5/8	2
85	830-027	Screw, 10-32 x 2	2	390	2261714	Washer, max foot pedal	2
90	830-094	Thru-bolt	2	395	2265115	Boot, foot pedal	1
95	990-051	Washer, steel	2	400	2254031	Switch, mom/off/con	1
100	990-052	Washer, nylatron	2	415	2332103	Screw 6-20 x 3/8	1
110	973-025	Spacer, brush plate	2	420	2260511	Pin, pivot, foot pedal	1
115	992-010	Washer, Belleville	2	425	2266610	Decal, on/off switch	1
120	990-045	Spacer, thrust	1	430	2992104	Foot pedal base	1
125	582-013	Clip, retaining, short, US2 only	1	435	2262301	Pully, foot pedal	1
135	640-020	Leadwire, black	1	440	2266401	Cover, pulley	1
136	640-125	Leadwire, red	1	445	2301310	Screw 8-18 x 1/2	2
137	640-317	Groundwire, brown, US2 only	1	450	2266413	Tension Screw	1
				455	2332103	Screw 6-20 x 3/8	2
200	2990140	Indicator assembly	1	460	2266412	Switch plate, foot pedal	1
205	2282730	Spring, indicator	1	465	2264056	Control board max 24/36	1
210	2285605	Decal, Cover 80#, fw	1	470	2264511	Bottom plate, max	1
	2285606	Decal, Cover 80# US2, fw	1	475	2372100	Screw 8-18 x 5/8	5
212	2285616	Decal, Control box, fw	2	480	2223455	Screw 10-32 x 1/2 zp	2
215	2280200	Cover, control box	1	485	2265126	Bumper pad, foot pedal	4
220	2232360	Pulley, cable drum	1	490	2378600	Pop rivet, 3/16 x 3/4 alum	4
225	2261730	Washer, nylon	1	■	2991550	Clamp collar assembly	1
230	2267800	Gear, indicator	1	500	2073102	Nut, 1/4-28 ss	1
235	2996247	Top bearing, pinion drive	1	510	2071550	Collar clamp, "A" side	1
240	2301310	Screw 8-18 x 1/2	1	515	2072621	Pin, knurled	1
245	2261905	Bracket, indicator	1	520	2071718	Washer #10 nylon retaining	1
250	2262221	Indicator, drive	1	525	2071555	Collar clamp, "B" side	1
255	2267800	Gear, indicator	2	530	2281505	Knob - Soft grip, FW	1
260	2223430	Screw 8 x 3/4	4	535	2075120	Pad, urethane, depth collar	1
265	2261901	Bracket, conduit	1	540	2263422	Screw 5/16-18 x 1	1
270	2282500	Control box	1	545	2281700	Washer 5/16 Lock	1
274	2372100	8-18 x 5/8	1	■	2991754	Bow guard assembly 45", 52"	1
275	2263201	Clamp, wire harness	2		2991755	Bow guard assembly 62"	1
280	2053414	8-32 x 1/2 tri-lobe	3	550	2281942	Bracket, top	1
285	2372100	Screw 8-18 x 2/8	4	555	2280001	Bearing, top bracket	1
290	2265110	Boot, control box	1	560	2071541	Spring sleeve, upper	1
295	2355410	Shrik tube 3/8	3	565	2282700	Spring, bowguard	1

Item	P/N	Description	Qty	Item	P/N	Description	Qty
570	2281525	Spacer, Spring 62" only	1	855	2283610	Bracket - latch/strap, rope pull	1
575	2281520	Spring sleeve, lower	1	860	2287300	Bushing, rear pivot	2
580	2991725	Bracket, bottom	1	865	2282602	Pin, 3/8 x 3 3/4	1
585	2263423	Screw 5/16-18 x 1 SHCS	3	870	2263011	E-ring, 3/8 shaft	2
586	2262632	Pin, spring 1/4 x 5/8	2	871	2280008	Bearing, Iglide	2
590	2266000	Bearing, ball, steel	1	875	2282720	Spring, extension	2
595	2266260	Bearing race	1	880	2773601	Latch strap assembly, Long	1
600	2992086	Tube w/ bearing race 24", 52"	1	885	2261732	Washer 8, nylon	2
	2992088	Tube w/ bearing race 28 1/2", 62"	1	890	2373450	Screw 8-18 x 3/8	2
605	2267307	Bushing outer tube	1	■	2993915	Sideplate assembly, long, left, fw	1
610	2266116	Bearing, Cartridge	1	895	2288625	Support, left sideplate	1
615	2266001	Bearing, split ring	1	900	2283408	Screw 8 x 3/8	8
620	2261622	Collar half	2	905	2283915	Sideplate, long, left, fw	1
625	2263453	Screw, 1/4-20 x 1 SHCS	2	910	2073408	Screw 1/4-20 x 7/8	2
630	2071560	Collar, Tube	1	915	2286700	Plug, spacer	2
635	2223468	Screw 8-32 x 7/16 flt hd	4	920	2283900	Ramp, motor	1
640	2032006	Tube 52"	1	■	2993925	Sideplate assembly, long, right, fw	1
	2032007	Tube 62"	1	925	2288620	Support, right sideplate	1
■	2991747	Mount, Fortrex, Long 80#	1	930	2283925	Sideplate, long, right, fw	1
700	2280800	Link, bowguard mount, left	1	932	2285502	Decal, Sideplate, fw	2
710	2287303	Bushing, upper pins	2	935	2281912	Base extrusion, long	1
715	2283409	Screw, 1/4-20 x 1" FHSC	4	940	2323405	Screw 1/4-20 x 1/2	6
720	2880400	Pull grip assembly	1	950	2256300	Tiewrap	1
721	2261732	Washer	2	955	2261238	Leadwire	1
725	2771601	Rope assembly	1				
730	2281516	Spacer, inner arm	1	975	2773806	Strap hold down	1
735	2281702	Washer, lock 1/4	1				
737	2284212	Outer arm, Long	1	980	2991925	Bracket stabilizer assembly	1
740	2992322	Rope guide assembly	1				
745	2281530	Insert, threaded	1	■	1378132	Propeller kit WW2	
750	2282608	Pin, 7/16 x 5 5/32	1	■	2994876	Propeller bag assy	
751	2282602	Pin, 3/8 x 3 3/4	1	1000	2331160	Propeller WW2	1
752	2261505	Spacer	2	1010	2262658	Drive pin, large	1
753	2263011	E-ring, 3/8 shaft	2	1015	2091701	Washer, prop, large	1
760	2223418	Screw, 1/4-20 x 1/2 BHCS	1	1020	2093101	Nut, nylock, prop, large	1
765	2993821	Inner arm assembly, long	1				
770	2042711	Spring, torsion	1	■	2994887	Mounting hardware bag assy	
775	2283620	Latch, safety	1				
776	2282611	Pin, safety latch	1	■	2889460	Seal & Oring Kit	
780	2281704	Washer 7/16 nylon	1				
785	2280805	Link, bowguard mount, right	1				
790	2283410	Screw 1/4-20 x 1/2 PFH	2				
795	2288404	Gas spring (cylinder), 80#, lg mt	1				
796	2281710	Spacer, gas spring	2				
800	2282610	Pin, upper, shock	1				
810	2280005	Bearing, nyliner 7/16"	4				
815	2282600	Pin, 7/16 x 4 7/8	1				
820	2281932	Bracket, rear pivot	2				
825	2281501	Yoke, shock mount	1				
830	2282606	Pin, 7/16 x 4 1/2	1				
835	2283402	Screw, set, 6-32 x 1/4	2				
845	2282604	Pin, Knurled 5/16 x 2	1				
850	2283615	Latch bar	1				

Minn Kota accessories available for your motor.



OnBoard Chargers



Portable Chargers



Stabilizer Kits



Quick Release Brackets



Circuit Breakers



Quick Plugs

Learn more about boat motors we have.