

The Raptor Port 4" & 6" Jack Plate Bracket installs directly to the Jack Plate on the Port side of your boat.

Item / Assembly	Part #	Description	Qty.
2	2351961	BRACKET, PORT 2/4 PAINTED	1
	2351963	BRKT, PORT 2/4, PAINT WHT *white*	1
4	2351960	BRACKET, PORT 2/6 PAINTED	1
	2351962	BRKT PORT 2/6, PAINT WHT *white*	1
▲	2354911	INSTRC-INSTALL, JACKPLATE	1
6	2353411	SCREW-3/8-16X1.75 SET SSTL *PRE-INSTALLED*	4
8	2353103	NUT-3/8-16, ACORN SS *PRE-INSTALLED*	4
10	2371758	WASHER-3/8 HD FLAT SS *PRE-INSTALLED*	4
12	2352901	RETAINER,STUD,ANCHOR BRKT *PRE-INSTALLED*	1
A Items 14 - 22	2994939	BAG ASM,JACKPLATE HDW,RPTR	1
14	2371757	WASHER-1/2", HEAVY DUTY, SS	4
16	2373108	NUT-1/2-13, NYLOC, SS	2
18	2373519	BOLT-1/2-13 X 3" HHCS SS	2
20	2353102	NUT-3/8-16 FLANGE,NYLOK,SS	4
22	2378608	ANTI SEIZE TUBE, 4CC	1

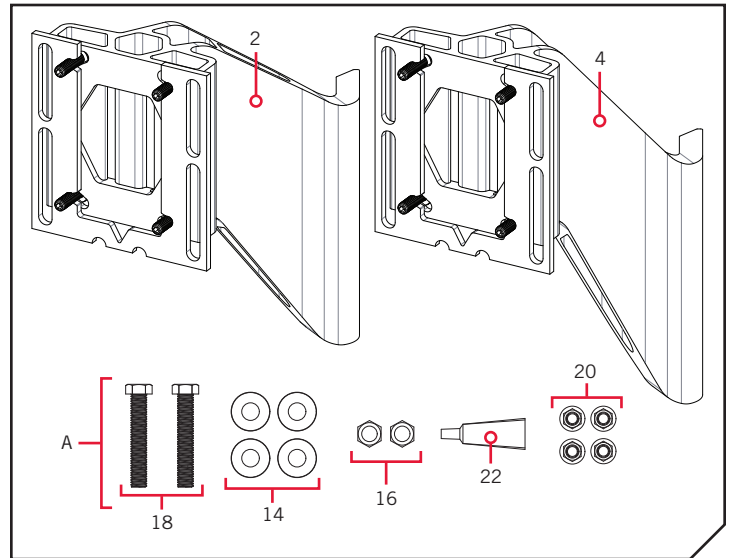

* This part is included in an assembly and cannot be ordered individually.

▲ Not shown on Parts Diagram.

NOTICE: The kit purchased will contain **either** Item #2 **or** Item #4 based on if a 4" (1810361 or 1810366 - white) or 6" (1810363 or 1810368 - white) Port rise was selected. This kit is mounted directly to the Port side of a Jack Plate. It may also be mounted directly to a Raptor Universal Sandwich Adapter (1810372 or 1810377 - white). The Raptor 3" Setback Bracket (1810370 or 1810375 - white) may be added to these Jack Plate brackets for additional mounting options.

TOOLS AND RESOURCES REQUIRED

- Torque Wrench
- 1/2" Box End or Socket Wrench
- A second person to help with installation

MOUNTING CONSIDERATIONS

Before mounting your Raptor Jack Plate Bracket, please give consideration to the following:

1. The Jack Plate Bracket will only work with compatible Jack Plate designs and may not work with all Jack Plates. Please refer to the chart below for compatible Jack Plate designs. Instructions follow by Jack Plate style in the order listed in the chart. If your Jack Plate is not listed use of the Universal Sandwich Adapter (1810372 or 1810377 - white) either between the transom and Jack Plate, or between the Jack Plate and Outboard will be necessary.

Manufacturer	Model	Offset
TH Marine	Atlas Hydraulic	4" Thru 12"
	Z-Lock Manual	6" Thru 12"
R&R Designs	Slidemaster Manual	6" Thru 12"
Bob's Machine Shop	Action Series	6" Thru 14"
	Standard Series	6" Thru 14"

2. Examine the Port side of your Jack Plate. Identify the holes to be used for installation, if your Jack Plate does not have pre-drilled holes ensure that you will not drill into any obstructions and that the hardware will be accessible for assembly.

2. The Raptor must have a clear, unobstructed path to operate. Check to make sure that your proposed location will allow the anchor to deploy and retract without hitting trim tabs, poling platforms, ladders, the engine or other obstructions. You should also consider your fishing methods when selecting the mounting location. Make sure that no interference exists between the Raptor and your engine during normal operation. With the location selected, trim the engine all the way up and all the way down, and steer the engine fully to the left and right to confirm proper engine clearance. Ensure there is a minimum of two to three inches of clearance from any point on the Raptor in all states of stow and deploy.

3. The bottom edge of the Raptor should never be less than 4" above the hull directly below the Raptor to prevent spray and drag conditions. This applies to any mounting configuration used.

4. Keep the Red Retainer on the Jack Plate Bracket in place during the installation until instructed to remove it. For all installations paired with an additional bracket, the Jack Plate Bracket must be installed prior to installing the Raptor or additional brackets.

NOTICE: If installing an additional bracket to the Jack Plate Bracket, keep the Red Retainer in place and follow the instructions included with the additional bracket. Do not install the 3" Setback Bracket before completing the installation of the Jack Plate Bracket to the Jack Plate.

5. It may be necessary to remove a factory equipped E-ladder for proper bracket installation. Due to the wide variety of E-ladders, Minn Kota is not responsible for the re-installation or re-location of any factory equipped E-ladder.

6. Bob's Machine Shop Jack Plates require that holes be drilled to accept the Adapter Bracket. A spacer kit must be used to install correctly; see Minn Kota Spacer Block accessory Part #1810212 or equivalent from Bob's Machine Shop.

NOTICE: Check with your Jack Plate or Outboard manufacturer to determine if additional hardware is needed to accommodate installing this bracket. Longer mounting bolts than originally provided by the outboard manufacturer may be needed for proper installation. Drilling holes may be required to accept the Jack Plate Bracket and may void your manufacturer's warranty. Minn Kota is not responsible for damages that may result.

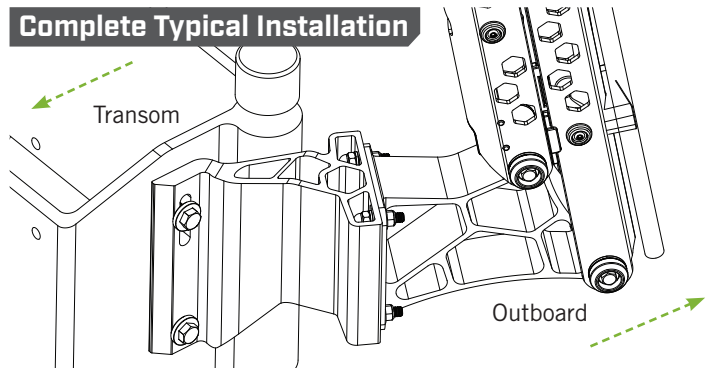
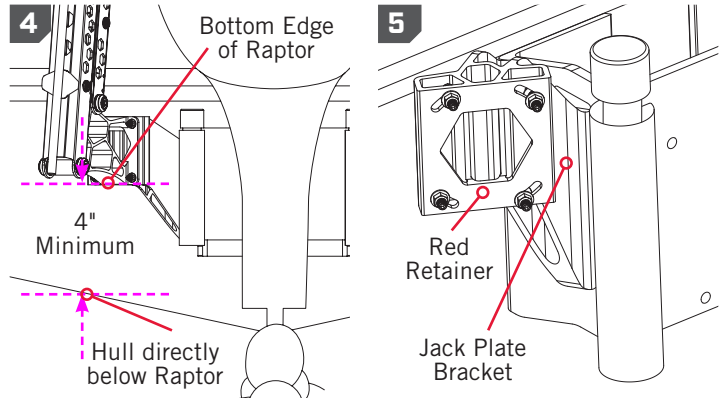
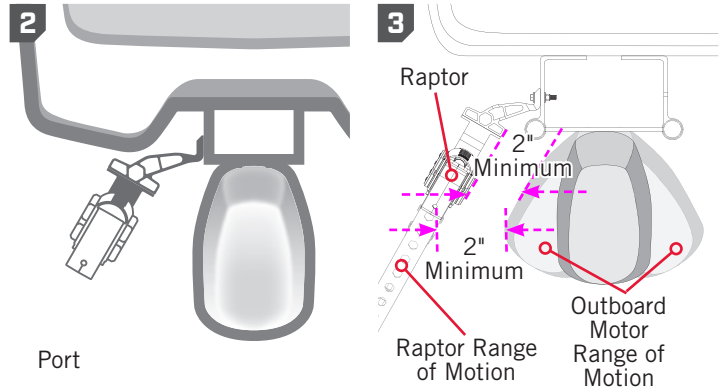

Installation to the Raptor Universal Sandwich Adapter

1

ITEM(S) NEEDED

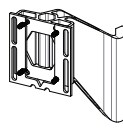

#2 x 1

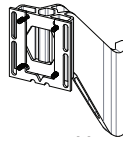

#4 x 1

- a. This Port Jack Plate Bracket (Item #2 or Item #4) will only be used to mount the Raptor to the Universal Sandwich Adapter if it was installed so that the Sandwich Bracket was oriented to the Port side of the boat. If installed for a Port mount, locate the Mounting Holes on the side of the Sandwich Bracket.
- b. Take the Port Jack Plate Bracket and align it with the Mounting Holes in the Sandwich Bracket. Orientate the Port Bracket so that the Red Retainer is facing Outboard and the Slotted Mounting Hole is upward.

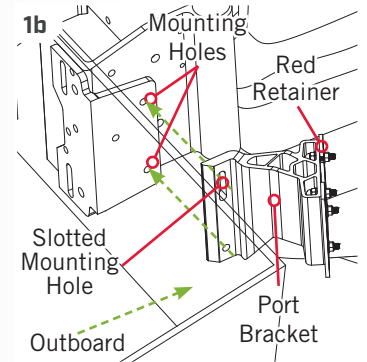
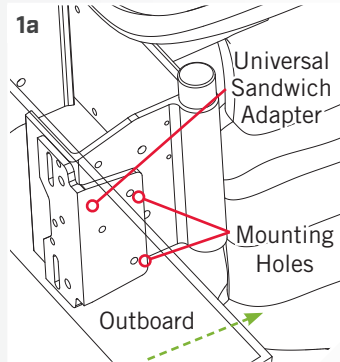

2

ITEM(S) NEEDED



#18 X 2



#14 x 4



#16 x 2



#22 x 1

- c. With the Port Bracket aligned, take two 3" Stainless Steel Hex Head Cap Screws (Item #18) and two Heavy Duty Stainless Steel Washers (Item #14). Place one Heavy Duty Washer on each of the Hex Head Cap Screws. Apply anti-seize on the threads of the Hex Head Cap Screws (Item #22).
- d. Insert the Hex Head Cap Screws with the Heavy Duty Washers in place through the Mounting Holes in the Port Bracket and into the Mounting Holes on the Sandwich Bracket.
- e. Take two Heavy Duty Stainless Steel Washers (Item #14) and place one on the end of each Hex Head Cap Screw on the opposite side of the Sandwich Bracket. Secure the hardware with two Stainless Steel Nylock Nuts (Item #16). Hold the Nylock Nuts with a 1/2" Open End Wrench and tighten the Hex Head Cap Screws with a 1/2" Socket Wrench. Check with your specific equipment manufacturer for their recommended settings. Tighten hardware to 50 ft-lbs.
- f. Continue to the "Completing the Installation" section of these instructions.

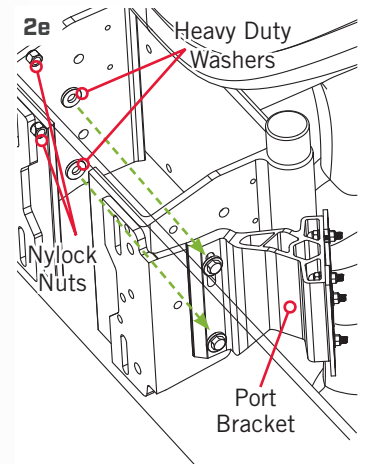
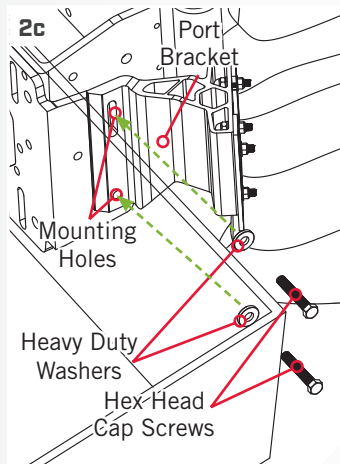

NOTICE: To prevent seizing of the stainless steel hardware, do not use high speed installation tools. Applying an anti-seize may help prevent seizing.



Installation with an Atlas Hydraulic Jack Plate

1

ITEM(S) NEEDED

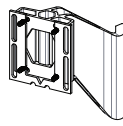

#2 x 1

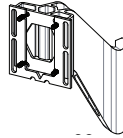

#4 x 1

- Locate the Mounting Holes on the side of the Atlas Jack Plate Bracket. The Mounting Holes may be located under the Jack Plate decal.
- Take the Port Jack Plate Bracket (Item #2 or Item #4) and align it with the Mounting Holes in the Port side of the Jack Plate. Orientate the Port Bracket so that the Red Retainer is facing Outboard and the Slotted Mounting Hole is upward.

1a

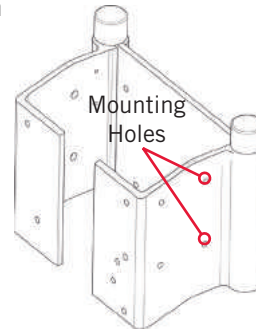

1b

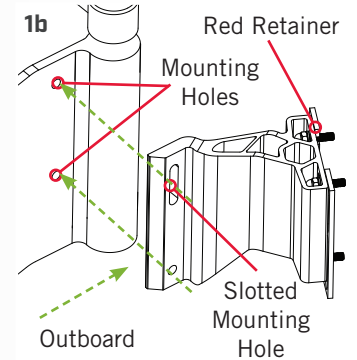

2

ITEM(S) NEEDED



#18 X 2



#14 x 4



#16 x 2



#22 x 1

- With the Port Bracket aligned, take two 3" Stainless Steel Hex Head Cap Screws (Item #18) and two Heavy Duty Stainless Steel Washers (Item #14). Place one Heavy Duty Washer on each of the Hex Head Cap Screws. Apply anti-seize on the threads of the Hex Head Cap Screws (Item #22).
- Insert the Hex Head Cap Screws with the Heavy Duty Washers in place through the Mounting Holes in the Port Bracket and into the Mounting Holes on the Port side of the Jack Plate.
- Take two Heavy Duty Stainless Steel Washers (Item #14) and place one on the end of each Hex Head Cap Screw on the inside of the Jack Plate. Secure the hardware with two Stainless Steel Nylock Nuts (Item #16). Hold the Nylock Nuts with a 1/2" Open End Wrench and tighten the Hex Head Cap Screws with a 1/2" Socket Wrench. Check with your specific equipment manufacturer for their recommended settings. Tighten hardware to 50 ft-lbs.
- Continue to the "Completing the Installation" section of these instructions.

2c

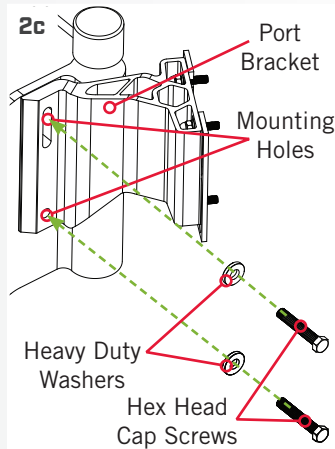

2e

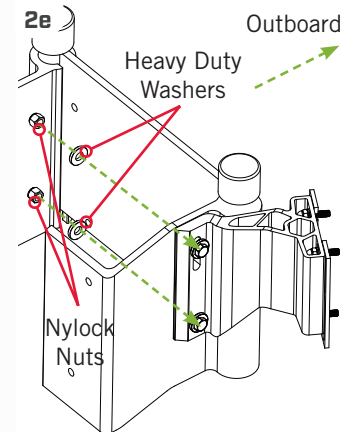

NOTICE: To prevent seizing of the stainless steel hardware, do not use high speed installation tools. Applying an anti-seize may help prevent seizing.

Installation with a Slidemaster Manual Jack Plate

⚠ CAUTION

Support the Outboard before any work has begun on the bracket installation. An unsecured motor may cause harm from falling. Make sure that all hardware is replaced and/or secure before moving or operating the boat or Outboard once installation is complete.

1

ITEM(S) NEEDED

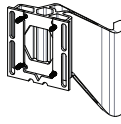

#2 x 1

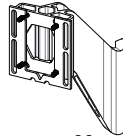

#4 x 1

- a. Locate the Mounting Holes on the Port side of the Slidemaster Manual Jack Plate. After supporting the Outboard, remove the hardware that is holding the Slide Bar and Inner Threaded Plate in place.

NOTICE: Any existing Side Bar should be removed and not reused. The Inner Threaded Plate that came with the Jack Plate will be reinstalled.

- b. Take the Port Jack Plate Bracket (Item #2 or Item #4) and align it with the Mounting Holes in the Port side of the Jack Plate. Orientate the Port Bracket so that the Red Retainer is facing Outboard and the Slotted Mounting Hole is upward. Position the Inner Threaded Plate back in place.

1a Inner Threaded Plate

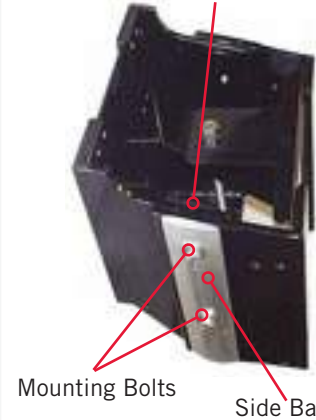

1b Inner Threaded Plate

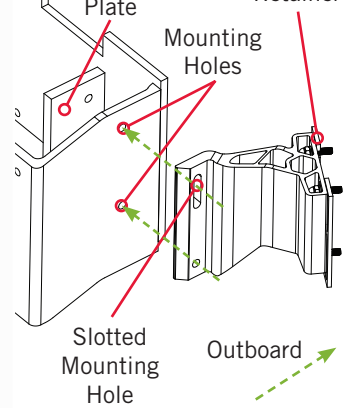

2

ITEM(S) NEEDED



#18 X 2



#14 x 2



#22 x 1

- c. With the Port Bracket aligned, take two 3" Stainless Steel Hex Head Cap Screws (Item #18) and two Heavy Duty Stainless Steel Washers (Item #14). Place one Heavy Duty Washer on each of the Hex Head Cap Screws. Apply anti-seize on the threads of the Hex Head Cap Screws (Item #22).
- d. Insert the Hex Head Cap Screws with the Heavy Duty Washers in place through the Mounting Holes in the Port Bracket, then into the Holes on the Port side of the Jack Plate and then into the Inner Threaded Plate.
- e. Hold the Inner Threaded Plate in place and use a 1/2" Open End Wrench or Socket Wrench tighten the Hex Head Cap Screws. Check with your specific equipment manufacturer for their recommended settings. Tighten hardware to 50 ft-lbs.
- f. Continue to the "Completing the Installation" section of these instructions.

2c Inner Threaded Plate

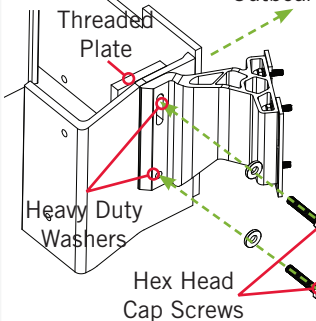

2e Inner Threaded Plate

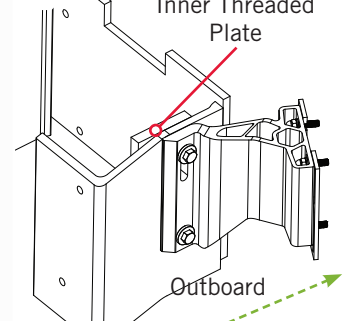

NOTICE: To prevent seizing of the stainless steel hardware, do not use high speed installation tools. Applying an anti-seize may help prevent seizing.

NOTICE: The hardware on the inside of the Jack Plate is secured into the Inner Threaded Plate. Two of the Heavy Duty Stainless Steel Washers (Item #14) and two of the Nylock Nuts (Item #16) will not be used.

Installation with a Z-Lock Manual Jack Plate

⚠ CAUTION

Support the Outboard before any work has begun on the bracket installation. An unsecured motor may cause harm from falling. Make sure that all hardware is replaced and/or secure before moving or operating the boat or Outboard once installation is complete.

1

ITEM(S) NEEDED

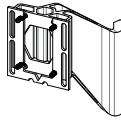

#2 x 1

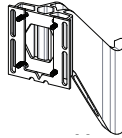

#4 x 1

- Locate the Mounting Holes on the Port side of the Z-Lock Manual Jack Plate. After supporting the Outboard, remove the hardware that is holding the Mounting Bolts in place.
- Take the Port Jack Plate Bracket (Item #2 or Item #4) and align it with the Mounting Holes in the Port side of the Jack Plate. Orientate the Port Bracket so that the Red Retainer is facing Outboard and the Slotted Mounting Hole is upward.

1a



Mounting Bolts

1b

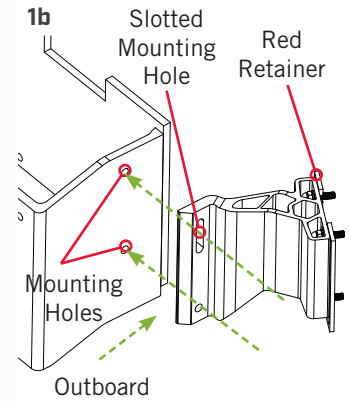

2

ITEM(S) NEEDED



#18 X 2



#14 x 4



#16 x 2



#22 x 1

- With the Port Bracket aligned, take two 3" Stainless Steel Hex Head Cap Screws (Item #18) and two Heavy Duty Stainless Steel Washers (Item #14). Place one Heavy Duty Washer on each of the Hex Head Cap Screws. Apply anti-seize on the threads of the Hex Head Cap Screws (Item #22).
- Insert the Hex Head Cap Screws with the Heavy Duty Washers in place through the Mounting Holes in the Port Bracket and into the Holes on the Port side of the Jack Plate.
- Take two Heavy Duty Stainless Steel Washers (Item #14) and place one on the end of each Hex Head Cap Screw on the inside of the Jack Plate. Secure the hardware with two Stainless Steel Nylock Nuts (Item #16). Hold the Nylock Nuts with a 1/2" Open End Wrench and tighten the Hex Head Cap Screws with a 1/2" Socket Wrench. Check with your specific equipment manufacturer for their recommended settings. Tighten hardware to 50 ft-lbs.
- Continue to the "Completing the Installation" section of these instructions.

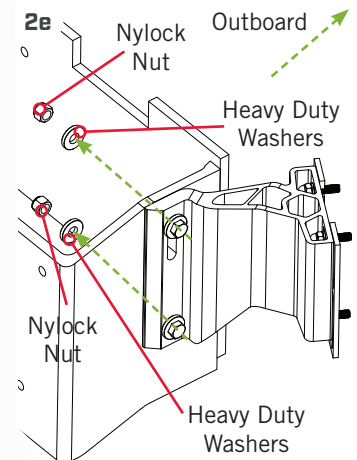
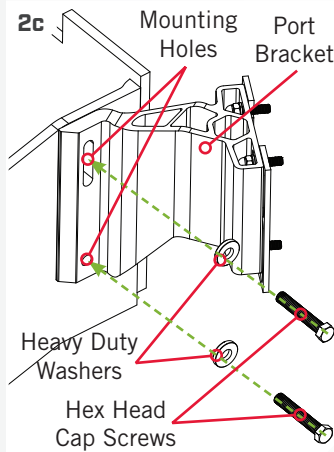

NOTICE: To prevent seizing of the stainless steel hardware, do not use high speed installation tools. Applying an anti-seize may help prevent seizing.

Installation with a Bob's Machine Shop Jack Plate

Installation of the Side Mount Adapter Bracket into a Bob's Machine Shop Jack Plate requires Spacer Block Kit 1810212.

1

ITEM(S) NEEDED

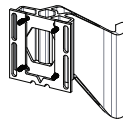

#2 x 1

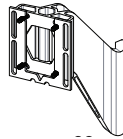

#4 x 1

- a. Locate the Mounting Holes on the Port side of the Bob's Machine Shop Jack Plate. For Bob's Machine Shop Jack Plates use Spacer Block Kit 1810212. Refer to the Installation Instructions provided with the Spacer Block Kit for more details.
- b. Take the Port Jack Plate Bracket (Item #2 or Item #4) and align it with the Mounting Holes in the Port side of the Jack Plate. Orientate the Port Bracket so that the Red Retainer is facing Outboard and the Slotted Mounting Hole is upward.

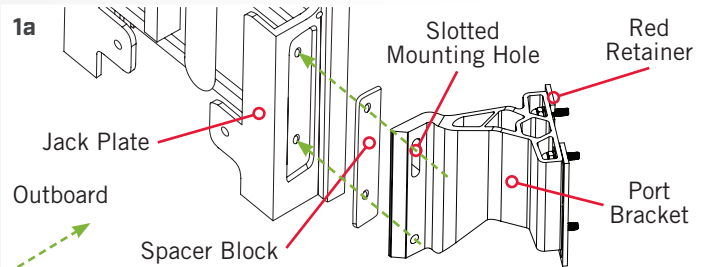
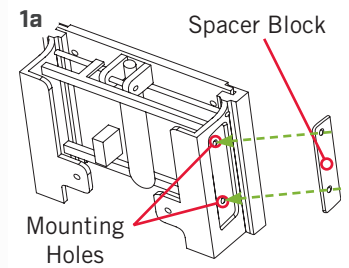
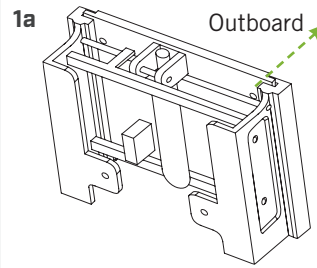

2

ITEM(S) NEEDED



#18 X 2



#14 x 4



#16 x 2



#22 x 1

- c. With the Port Bracket and Spacer Block aligned, take two 3" Stainless Steel Hex Head Cap Screws (Item #18) and two Heavy Duty Stainless Steel Washers (Item #14). Place one Heavy Duty Washer on each of the Hex Head Cap Screws. Apply anti-seize on the threads of the Hex Head Cap Screws (Item #22).
- d. Insert the Hex Head Cap Screws with the Heavy Duty Washers in place through the Mounting Holes in the Port Bracket and Spacer Block and into the Holes on the Port side of the Jack Plate.
- e. Take two Heavy Duty Stainless Steel Washers (Item #14) and place one on the end of each Hex Head Cap Screw on the inside of the Jack Plate. Secure the hardware with two Stainless Steel Nylock Nuts (Item #16). Hold the Nylock Nuts with a 1/2" Open End Wrench and tighten the Hex Head Cap Screws with a 1/2" Socket Wrench. Check with your specific equipment manufacturer for their recommended settings. Tighten hardware to 50 ft-lbs.
- f. Continue to the "Completing the Installation" section of these instructions.

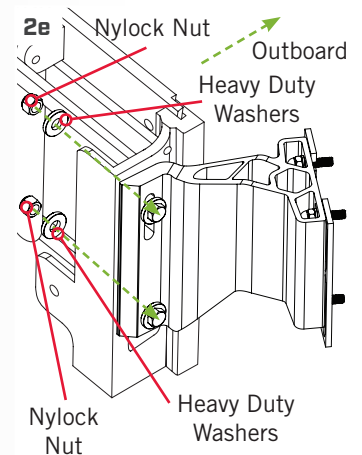
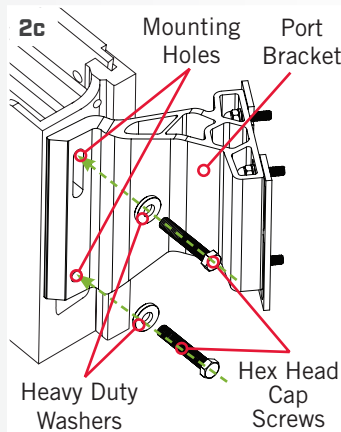

NOTICE: To prevent seizing of the stainless steel hardware, do not use high speed installation tools. Applying an anti-seize may help prevent seizing.

Completing the Installation

1

- a. Begin with the Port Bracket already installed to the Jack Plate. For specific instructions, please refer to the installation for each type of Jack Plate above. Once the Jack Plate Bracket is secured, leave the hardware and Red Retainer in place until instructed to remove it and continue below.

NOTICE: It is recommended to have a second person help with installation.

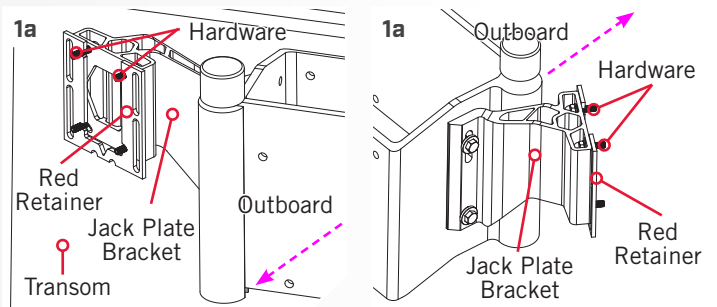

2

ITEM(S) NEEDED

◎ #20 X 4

 #22 x 1

- b. With the help of a second person, position the Built-in Mounting Bracket on the Raptor, so that the hardware in the Red Retainer on the Port Jack Plate Bracket aligns with the Mounting Holes in the Built-in Mounting Bracket. Apply Anti-seize (Item #22) to the threads of the hardware held in place by the Red Retainer. Then install the Built-in Mounting Bracket to the hardware.

NOTICE: The Red Retainer helps to align the hardware in the Jack Plate Bracket with the Mounting Holes in the Built-in Mounting Bracket to aide in installation. Keep the Red Retainer in place until instructed to remove it.

- c. Take four of the Flange Nuts (Item #20) and place one on the end of each of the Hex Head Cap Screws. Secure them loosely.

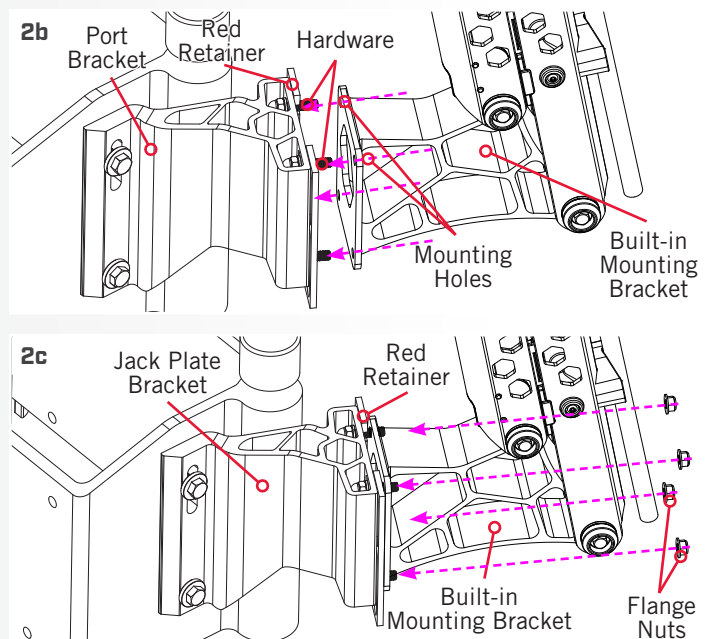

- d. With the Flange Nuts in place, pull the Red Retainer out to release the hardware. There are handles on each side of the Red Retainer that can be used to grasp each half. When pulling the Red Retainer, grasp each side and pull so that the Red Retainer breaks at the center and releases the hardware.

NOTICE: The Mounting Holes on the Jack Plate are slotted so that the Raptor can be adjusted along the slots for the final installation.

- e. With the Red Retainer removed, there is slack in the mounting hardware between the Port Jack Plate Bracket and Built-in Mounting Bracket. This allows the Built-in Mounting Bracket and Raptor to be rotated for final Raptor placement along the Slotted Holes in the Port Bracket. Check the angle of the bracket along the Slotted Holes and confirm that the Raptor is set at the desired angle. Once set, hold the hardware inside the Jack Plate Bracket with a 9/16" Open End Wrench. Tighten the Flange Nuts with a 9/16" Box End or Socket Wrench. Do not over-tighten. Tighten to 20 ft-lbs.

