

The Raptor Direct Mount Angle Bracket can be installed directly to either the port or starboard transom of the boat.

Item / Assembly	Part #	Description	Qty.
2	2351924	BRACKET,DIRECT MNT PAINTED	1
	2351928	BRKT, DIRECT MNT, PAINT WHT *white*	1
▲	2354913	INSTRC-INSTALL, DIRECT MNT	1
A Items 4 - 10	2994940	BAG ASM,SETBACK HDW,RPTR	1
4	2371758	WASHER-3/8 HD FLAT SS	4
6	2353102	NUT-3/8-16 FLANGE,NYLOK,SS	4
8	2383422	SCREW-3/8-16 X 1 1/4 HHCS SS	4
10	2378608	ANTI SEIZE TUBE, 4CC	1

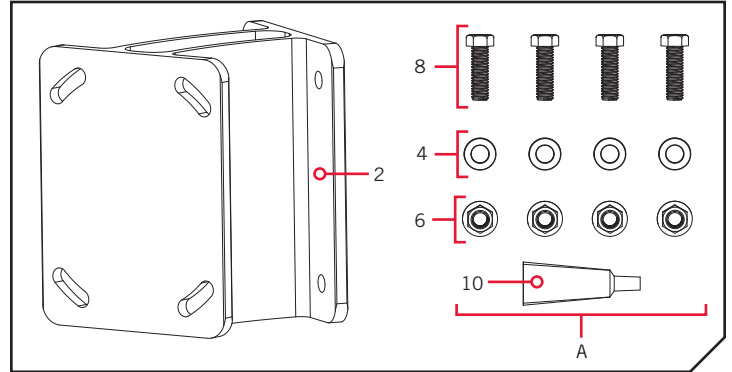

✳ This part is included in an assembly and cannot be ordered individually.

▲ Not shown on Parts Diagram.

NOTICE: For use with Raptor Shallow Water Anchors. Use the Direct Mount Angle Bracket (1810371 and 1810376 - white) when additional setback is needed and the Raptor needs to be offset to provide mounting clearance. May be mounted directly to either the Port or Starboard of the transom. The 3" Setback Bracket (1810370 and 1810375 - white) may also be paired with the Raptor Direct Mount Angle Bracket.

TOOLS AND RESOURCES REQUIRED

- Drill
- 9/16" Box End or Socket Wrench
- Marine Grade Sealant
- 20ft/lb capacity Torque Wrench
- Awl or similar marking tool
- Masking Tape
- A second person to help with installation
- 7/16" Drill Bit
- File, sand paper, or emery board
- Installation Hardware Kit 2994943 included with Raptor

MOUNTING CONSIDERATIONS

Before mounting your Raptor Direct Mount Adapter Bracket, please give consideration to the following:

1. Unobstructed Mounting - When selecting the mounting location, examine your boat to ensure that you will not drill into any obstructions and that the hardware will be accessible for assembly. Make sure that the Transom is strong enough to accept the Raptor mounted at the intended location.

2. Unobstructed Deployment and Retraction - The Raptor is designed to mount on either the port or starboard side of the transom. The Raptor must have a clear, unobstructed path to deploy. Check to make sure that your proposed location will allow the anchor to deploy and retract without hitting trim tabs, poling platforms, ladders, the engine or other obstructions. You should also consider your fishing methods when selecting the mounting location.

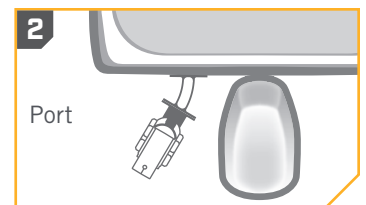
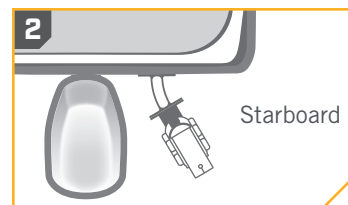
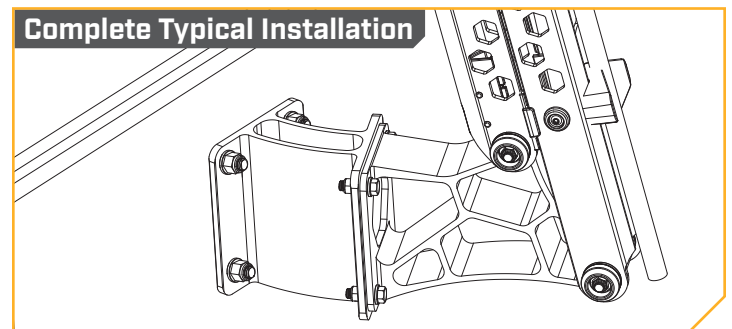

NOTICE: When mounting the Direct Mount Angle Bracket to the Transom it is recommended to review the additional mounting considerations for the complete installation of the Raptor. They can be found online at minnkotamotors.com in the "Installation" section of the Raptor Owner's Manual or Installation Instructions. They including how to mount the Hydraulic Pump and route the Hydraulic Hoses along with other recommendations. To add the 3" Setback Bracket (1810370 or 1810375 - white), finish the installation of the Direct Mount Bracket (Item #2) and then find additional instructions in the 3" Setback Bracket Installation Instructions.

3. Raptor to Hull Clearance - The bottom edge of the Raptor should never be less than 4" above the hull directly below the Raptor to prevent spray and drag conditions.

4. Raptor to Engine Clearance - When selecting a mounting location, make sure that no interference exists between the Raptor and your engine during normal operation. Once you have selected your mounting location, trim the engine all the way up and all the way down, and steer the engine fully to the left and right to confirm proper engine clearance. Ensure there is a minimum of two to three inches of clearance from any point on the Raptor in all states of stow and deploy.

5. Outboard Slotted Mounting Holes - When mounted on either the Port or Starboard side, the bracket should always be oriented to face away from the engine, with the slotted holes facing away from the transom.

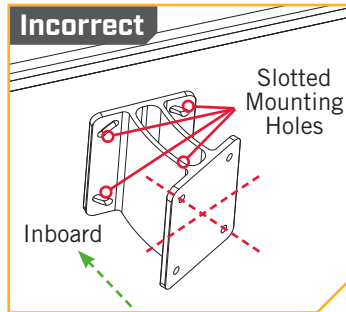
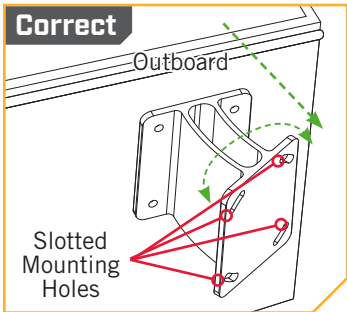
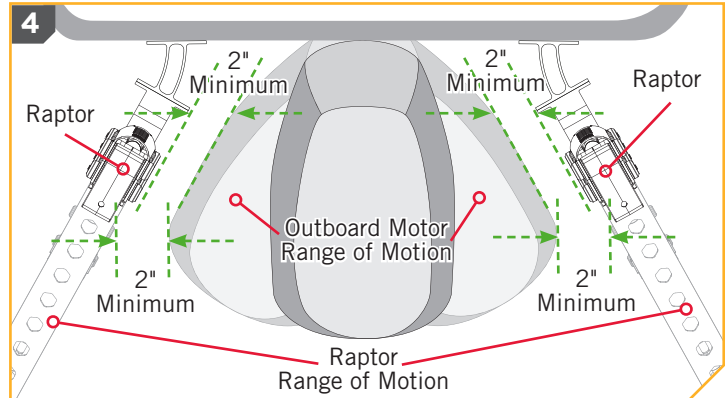
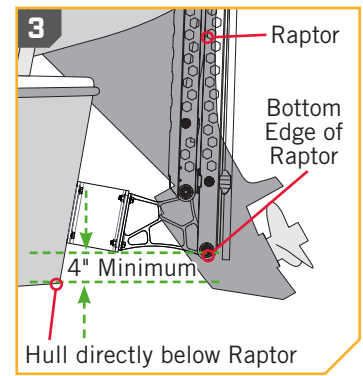
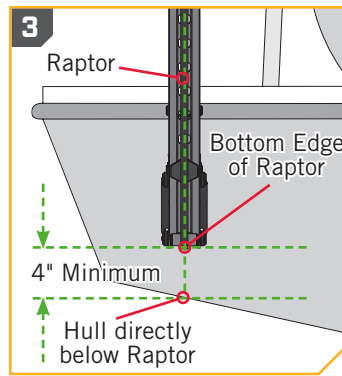

NOTICE: To prevent seizing of the stainless steel hardware, do not use high speed installation tools. Wetting the screws or applying an anti-seize may help prevent seizing.

INSTALLATION

Installing the Direct Mount Angle Bracket

1

ITEM(S) NEEDED

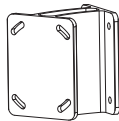

#2 x 1

- a. Review the Mounting Considerations to determine if it is acceptable to complete a direct mount of the Raptor Direct Mount Angle Bracket. If acceptable, position the Direct Mount Angle Bracket (Item #2) at the selected location. Make sure that the Slotted Mounting Holes are positioned away from the Transom and facing Outboard. With the bracket level and in place, mark all four Mounting Holes with an awl or similar marking tool.

NOTICE: It is recommended to have a second person help with installation.

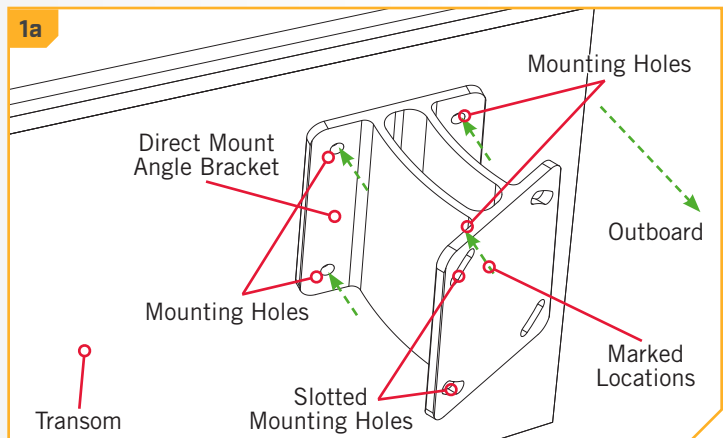

2

- b. Double check that the mounting location is clear to drill holes and then use a Drill with a 7/16" Drill Bit to drill through the Transom/Stern of the boat on the marked locations.

NOTICE: When drilling holes into fiberglass, it is helpful to first cover the surface with masking tape. This will help keep the boat surface unmarked and help with cleanup. Cover the surface and then mark the location to drill. Once the holes are drilled, remove the masking tape before continuing installation.

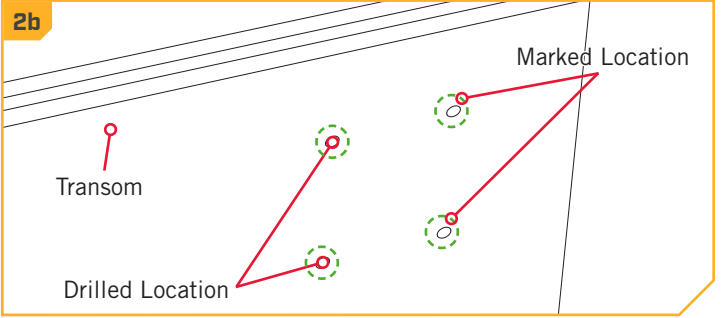

NOTICE: When drilling the marked holes, make sure that the drill bit is perpendicular to the Transom/Stern of the boat and that the holes are being drilled straight. Not drilling the holes straight will give the mounting hardware a poor fit.

3

- c. Place a 1/8" bead of Marine Grade Sealant on the Transom of the boat around the drilled holes.
- d. Place the Marine Grade Sealant around the Mounting Holes on the face of the Direct Mount Angle Bracket that will contact the boat Transom/Stern when mounted. Keep the sealant approximately centered between the outside edge of the Mounting Bracket and the Mounting Holes. Once the sealant is in place, align the Direct Mount Angle Bracket in the desired orientation with the holes that were drilled in the Transom/Stern.

NOTICE: To install the Raptor Direct Mount Angle Bracket to the boat, the Hardware Kit (Assembly 2994943) included with the Raptor will be needed. This includes Four (Part #2371758) Flat Head Stainless Steel Washers, Four (Part #2371759) Stainless Steel Fender Washers, Four (Part #2383421) 3/8 - 16 X 3 1/2 Stainless Steel Hex Head Cap Screws, Four (Part #2353102) Stainless Steel Nylock Flange Nuts and anti-seize.

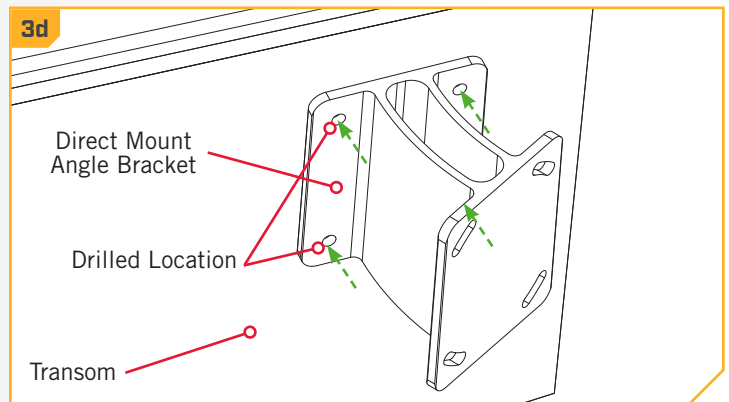
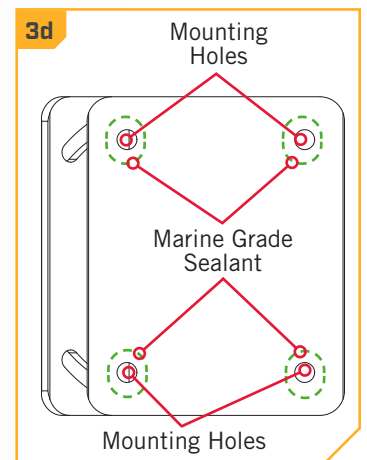
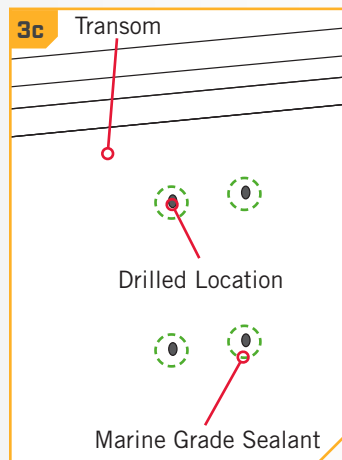

4

ITEM(S) NEEDED



- e. To install the Direct Mount Angle bracket to the Transom, use the Mounting Hardware Kit 2994943 provided with the Raptor. Take each of the four 3-1/2" Stainless Steel Hex Head Cap Screws (Part #2383421) and place one Flat Washer (Part #2371758) on them. Apply anti-seize (Item #10) to the hardware. The Hex Head Cap Screws will pass through the Flat Washers, into the Direct Mount Angle Bracket and through the Drilled locations on the Boat.
- f. Place a Fender Washer (Part #2371759) on the end of each Screw on the inside of the Transom and then secure each with a Flange Nut (Part #2353102). Apply anti-seize to the threads before tightening. Tighten the screws with a 9/16" Box End or Socket Wrench. Do not over-tighten. Tighten to 20 ft-lbs.

NOTICE: To prevent seizing of the stainless steel hardware, do not use high speed installation tools. Applying an anti-seize may help prevent seizing.

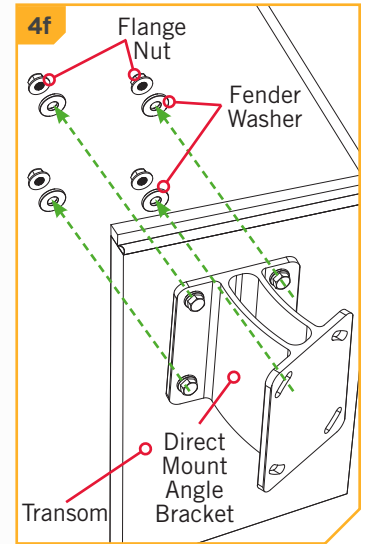
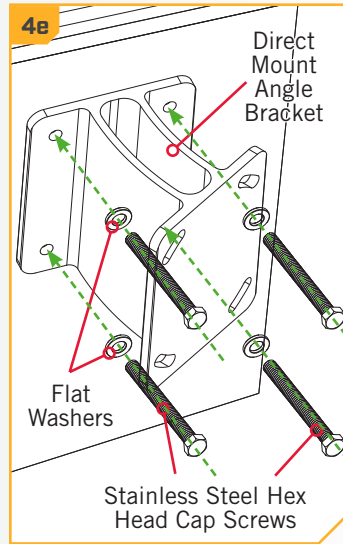

NOTICE: An alternate option is to mount the bracket, by passing the Hex Head Cap Screw with the Fender Washer from the inside of the transom to the outside. Pass the Screws into the Drilled Locations. Then pass them into the Direct Mount Angle Bracket. Secure on the outside of the boat with the Flat Washer and Flange Nut.

5

ITEM(S) NEEDED

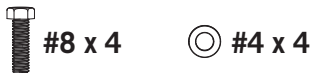

- g. With the Direct Mount Angle Bracket secured to the Transom, take the Raptor and align the Raptor Mounting Bracket with the Slotted Holes on the Direct Mount Angle Bracket. Notice that the holes are slotted so that the Raptor can be adjusted along the slots for the final installation.
- h. With the help of a second person, hold the Raptor in place to install the mounting hardware. Take the four 1-1/4" Stainless Steel Hex Head Cap Screws (Item #8) and four of the Stainless Steel Flat Washers (Item #4). Place a Washer on the end of each Screw and then apply anti-seize to the threads of each Screw. Insert each Screw into the Raptor Mounting Bracket and then into the Direct Mount Angle Bracket.

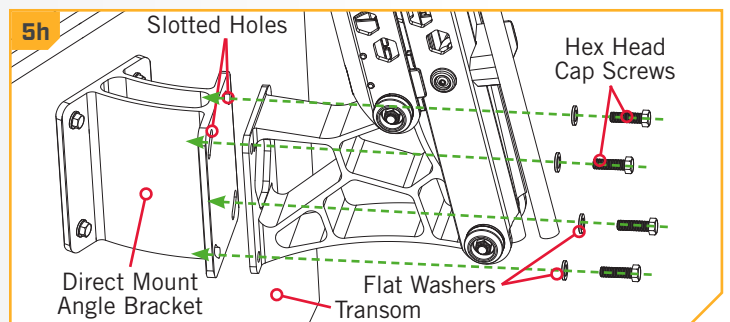
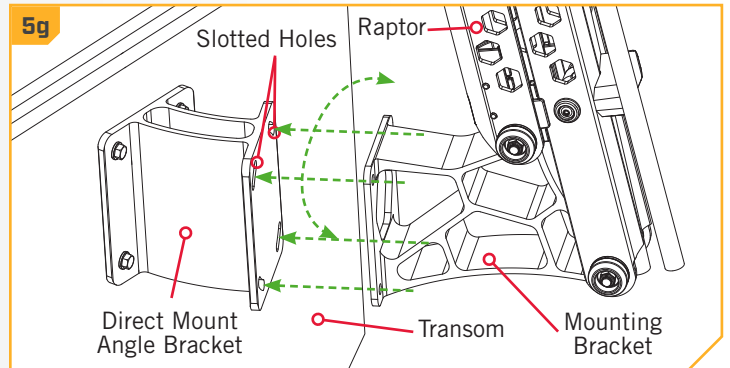

ITEM(S) NEEDED

◎ #6 x 4

- i. Take four of the Flange Nuts and place one on the end of each of the Hex Head Cap Screws. Secure them loosely.
- j. Then check the angle of the bracket along the Slotted Holes and confirm that the Raptor is set at the desired angle along the holes. Apply anti-seize to the threads before tightening. Once set, tighten the Flange Nuts with a 9/16" Box End or Socket Wrench. Do not over-tighten. Tighten to 20 ft-lbs.

